

DP-DNHBE-WZ CONSTRUCTION ASSEMBLY INSTRUCTIONS



Manufacturer: BAKS – Kazimierz Sielski

ul. Jagodne 5

05-480 Karczew

Poland

Steel structure for flat roof in ballasted version.

Mounting of PV panels in a horizontal arrangement (horizontally).



1. Necessary tools for assembling the structure

- Allen spanner (ampoule spanner) size 6
- Cordless screwdriver with speed and torque control
- Hexagon socket wrench, hexagon size 6 for screwdriver head
- Combination spanners in sizes 13, 15, 17 mm
- Ratchet spanner with sockets in sizes 13, 15, 17 mm
- Extension piece 100-120mm for socket spanners
- Rubber mallet
- Torque spanner, range 10-45 Nm

2. General information:

- Structures can be used in wind and snow zones in accordance with the following standards: **EN 1991-1-3** and **EN 1991-1-4**
- **Before assembling the structure, please read the installation instructions for the photovoltaic panels.**
- Ballast values and locations to be determined individually by the authorized constructor
- Tighten **SAM8x...E** screws and **NKZM8E** nuts to a torque of 12-14 Nm.
- When tightening the **SGKFM8x20** and **SGKFM10x20PV** screw, hold the head of the screw in such a position that the underlay is blocked on the walls of the hole in which the screw is installed, and then, using a screwdriver, tighten the screw slowly until it is blocked in the hole. At the final stage, tighten the screw with the screwdriver successively with a torque of: M8 - 22 Nm; M10 - 42 Nm
- Tighten **SRM10x...F** screws to a torque of 20 Nm



3. Summary of components of the DP-DNHBE-WZ construction

No.	Product	Name of product	Designation in construction
1	Support Channel	CMP41H41/...MC	Support profile
2	Bottom holder	UPDMC	Panel support
3	Top holder	UPG...MC	Panel support
4	Side holder	BUFK...	Side panel mounting clamp
5	Middle holder	PUFK	Middle clamp for mounting the panels
6	Mushroom head screw	SGKFM...	Screw + flange nut
7	Ballast base	PBK40MC	Base for ballast
		PBKD40MC	Base for ballast for increased ballast capacity (optional)
8	Screw with rhomboid nut	SRM10x30F	Mounting of UPG and UPDC holders
9	Channel base with vibration isolating rubber	PC50P	Prevents pressing of the steel profiles endings against the roof sheathing
10	Grounding washer	PUPK	Panel grounding
11	Protective cap	NOWPAL40x40SR	Protects steel profiles endings
12	Vibration-insulating rubber	SBV...	Separation between the elements of the substructure between support structure elements and roof sheathing

4. Assembly of DP-DNHBE-WZ structure

The A and B dimensions (dimension B is the module length + 20mm) depend on the size of the modules to be fitted. This must be determined by physically fitting the module onto the mounted UPG...MC and UPDMC holders.

The maximum size of modules that can be correctly mounted on a DP-DNHBE-WZ structure is: 2100mm long x 1150mm wide (to be verified with module manufacturer)

Grounding washers of the PUPK type should be placed at the mounting points of the PUFK middle holders.

Where there are an even number of modules in a single row of construction, grounding washers are fitted every second pair of modules.

In the case of an odd number of modules, grounding washers must additionally be added under the extreme PUFK holders to ensure that the last module is also grounded.



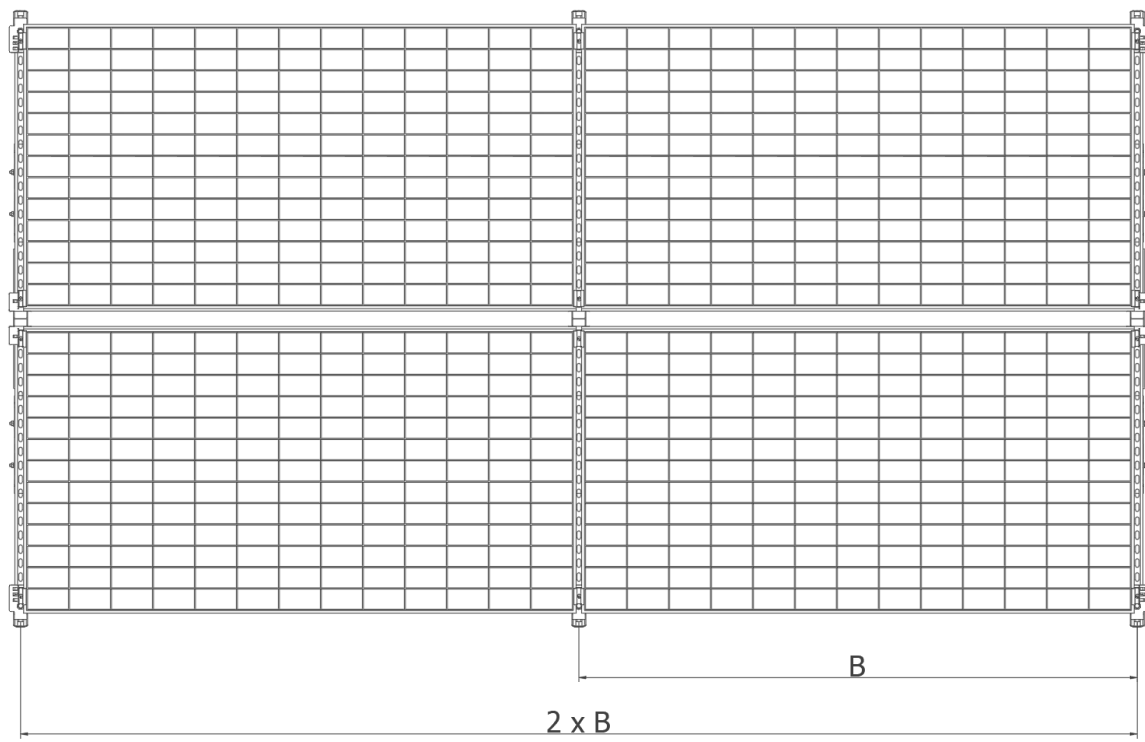
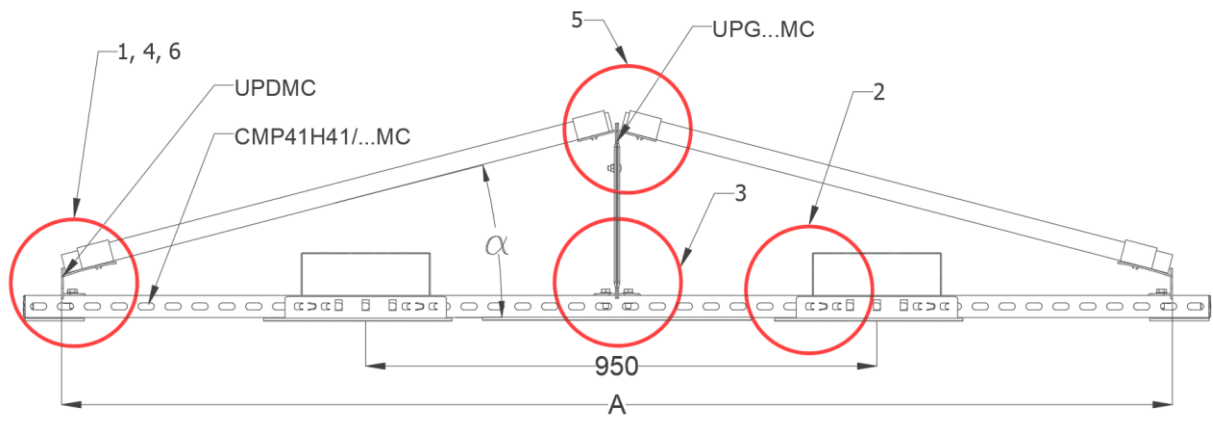

1

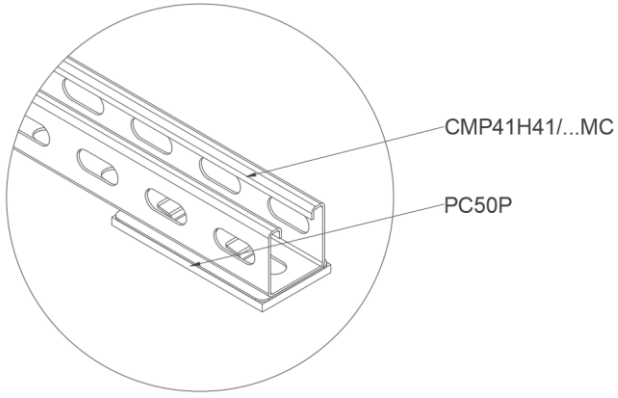

2

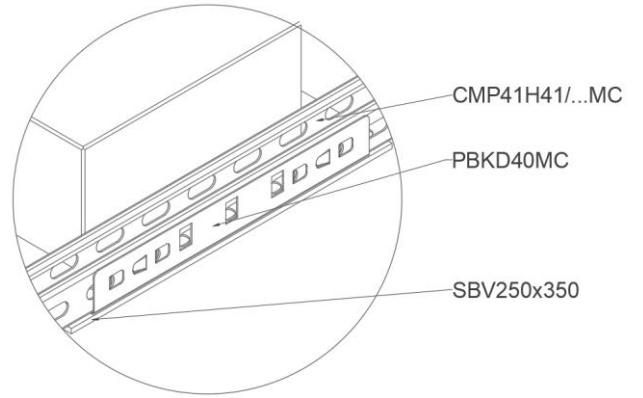

3

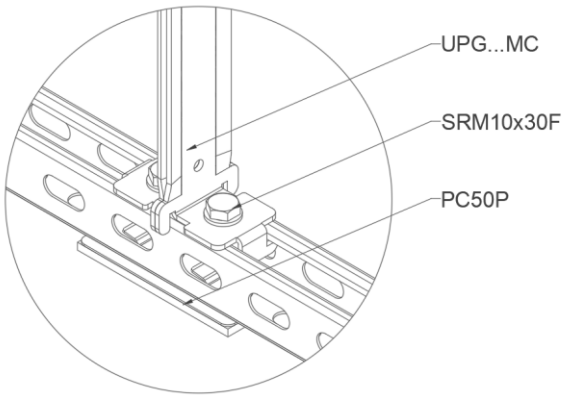

4

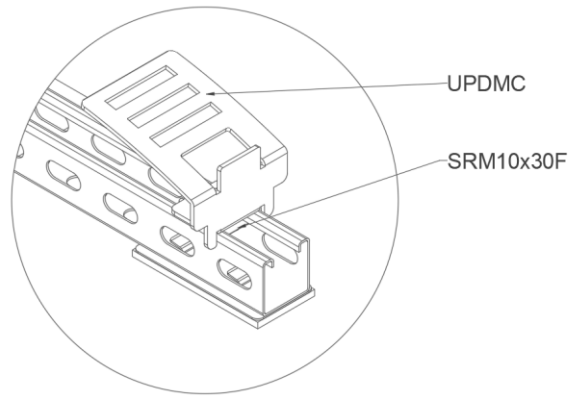

5

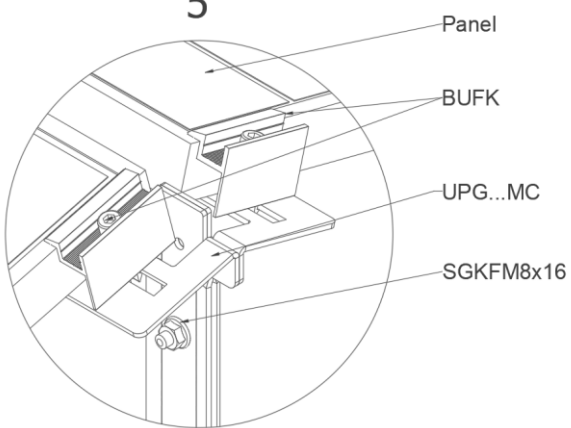

6

