

CONSTRUCTION ASSEMBLY INSTRUCTIONS DP-DTHKN-WZ



Producer: BAKS – Kazimierz Sielski

ul. Jagodne 5

05-480 Karczew

Poland

Steel structure for flat roof in anchored version.

Installation of PV panels in a horizontal (horizontal) arrangement



1. Essential tools for assembling the structure

- Allen spanner (ampoule spanner) size 6
- Cordless screwdriver with speed and torque control
- Hexagon socket wrench, size 6 for screwdriver head
- Open-end spanner, size 13, 15, 17 mm
- Ratchet spanner with socket size 13, 15, 17 mm
- Extension piece 100-120mm for socket spanners
- Rubber mallet
- Torque spanner, range 10-45 Nm

2. General information:

- Possibility of using the structure in wind and snow zones in accordance with the following standards: PN-EN 1991-1-3 and PN-EN 1991-1-4.
- Before installing the structure, read the installation instructions for photovoltaic panels Ballast values determined individually by a licensed builder
- SAM8x screws... E and NUTS NRM8PV should be tightened with a torque of 12-14 Nm
- When tightening the SGKFM8x20 and SGKFM10x20PV screw, hold the screw head with your hand the head of the screw in such a position that the undersink locks on the walls of the hole where the screw is installed, and then using a screwdriver tighten the screw slowly until it locks in the hole. At the final stage, tighten the screw with a screwdriver successively with a torque of: M8 - 22 Nm; M10 - 42 Nm
- Tighten the screws SMM10x...F to a torque of 30 Nm



3. Summary of components of the DP-DTHKN-WZ construction

Nr	Product	Name of product	Designation in construction
1	Channel	CC55H50/...MC	Main profile
2	Channel	CP50H35/...MC	Structure assembly profile
3	Channel	CC50H35/...MC	Panel support profile
4	Channel connector	LCCW50H35MC	Connecting channels CC50H35/...MC
5	Hexagonal head screw	SMM10x70F	Screw connecting the supporting channels of the structure
6	Washer	PP10F	Washer
7	Top base east-west	PGWZMC	Assembly of the structure in the East-West variant.
8	Side holder	BUFMC	Panel mounting holder
9	Screw	SAM8x25E	Mounting screw for holders and wind shields
10	Rhomboid nut	NRKM8PV	Rhomboid nut
11	Spring washer	PS8E	Spring washer
12	Enlarged washer	PW8E	Enlarged washer
13	Mushroom head screw	SGKFM10x20	Screw + flange nut
14	Anchor	PSRM10x90F	An example of an anchor holding the structure
15	Vibration isolation rubber	SBV500x500	Separation between the elements of the support structure of the support structure and the roof sheathing
16	Channel base with vibration isolation rubber	PC100C	Prevents pressure of steel profile ends on roof sheathing



4. Assembly of DP-DTHKN-WZ construction

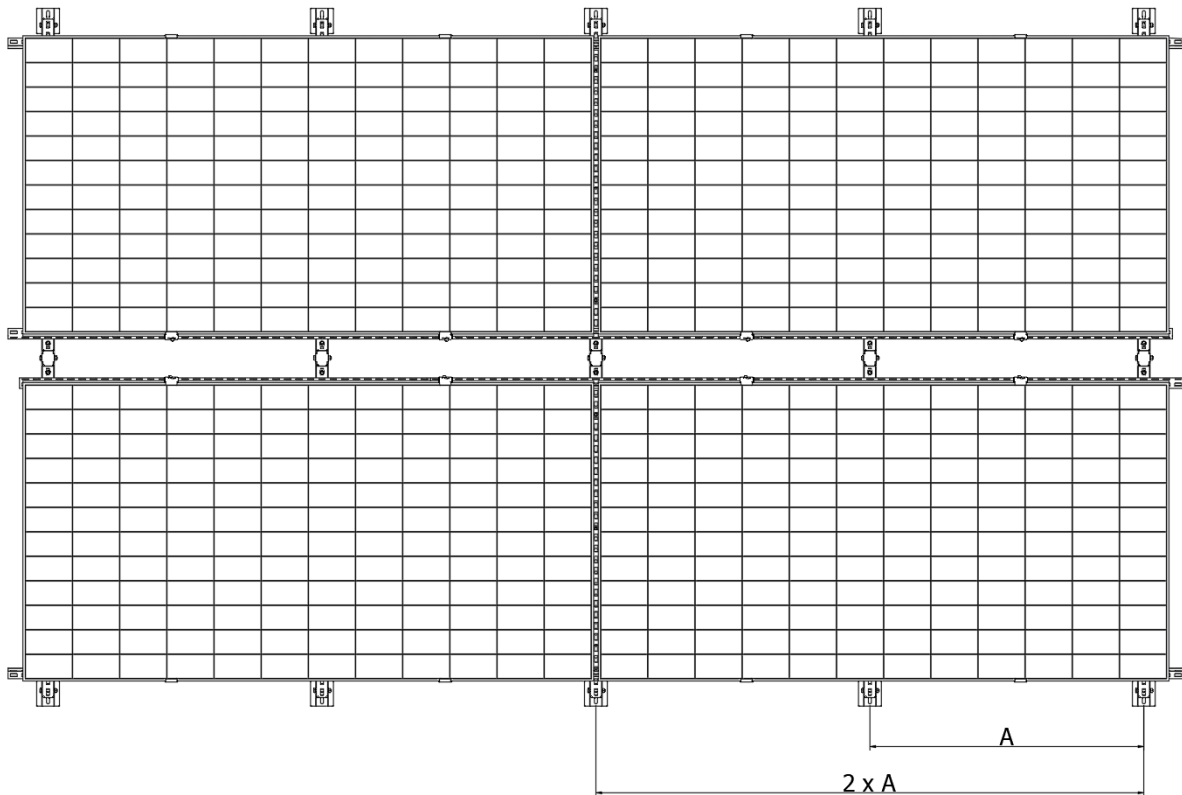
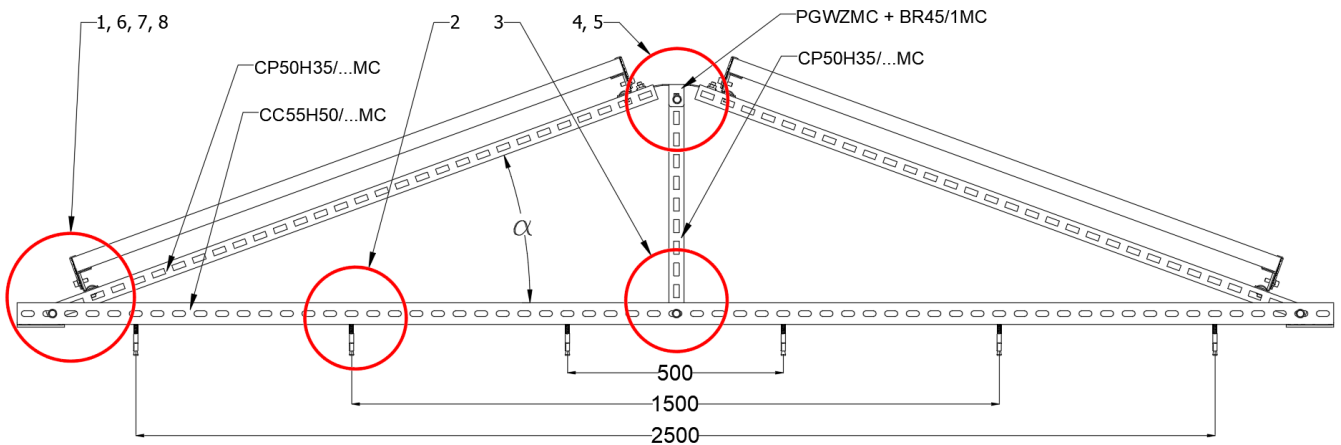

Combination of wind "W" and snow "S" * zones	Maximum distance of subsequent "A" frames
1W-1S; 1W-2S; 1W-3S	2,0 m
1W-4S	1,8 m
2W-2S; 2W-3S	1,4 m
3W-1S	1,6 m
3W-3S	1,3 m
3W-5S	1,1 m
Other combinations of zones	Selected individually after consultation

Table 1 Installation distance of subsequent frames of the photovoltaic structure depending on the combination of wind and snow zones

*1 wind zone below 300m asl; 3 wind zone below 500m asl;

1 and 3 snow zone below 300m asl; 5 snow zone below 500m asl.



1

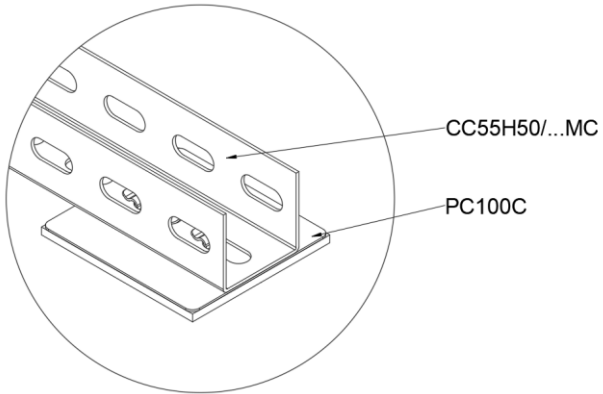

2

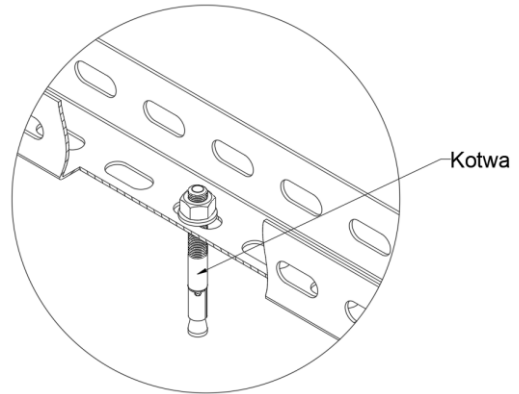

3

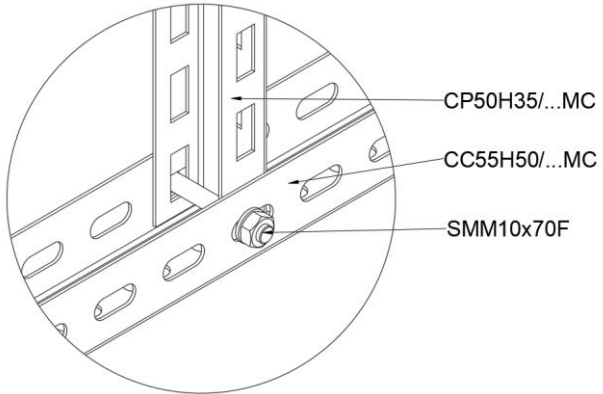

4

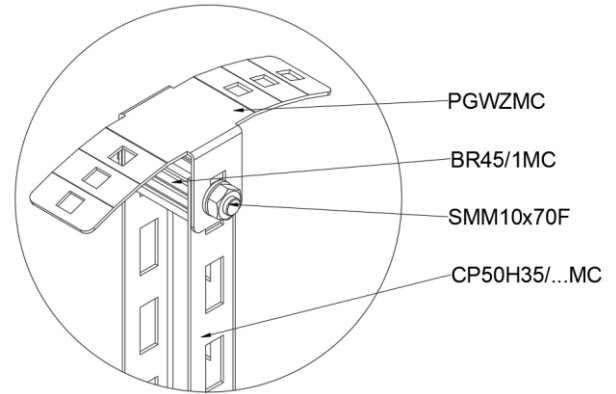

5

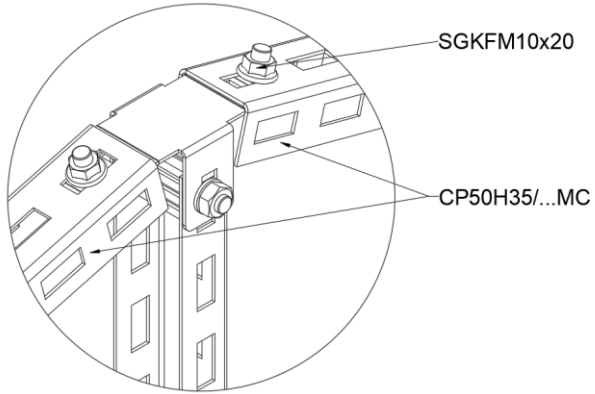

6

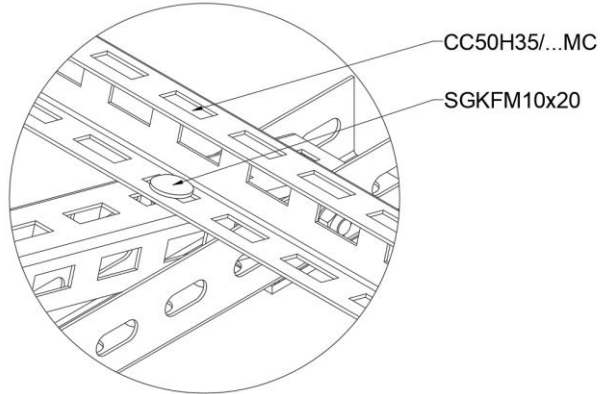

7

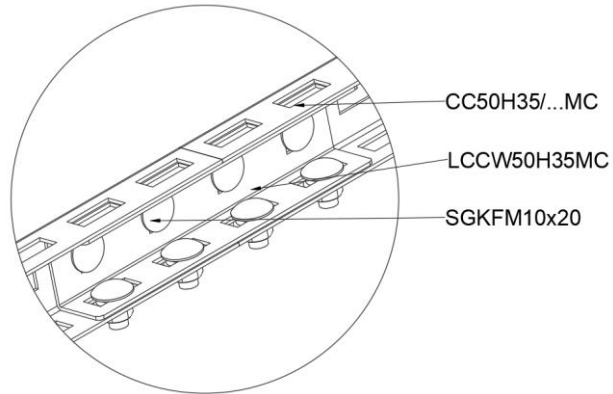

8

