

CONSTRUCTION ASSEMBLY INSTRUCTIONS E-VKRN

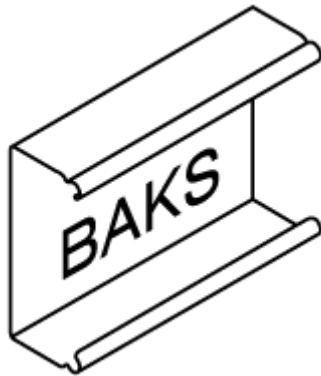

Producer: BAKS – Kazimierz Sielski

ul. Jagodne 5

05-480 Karczew

Poland

Steel facade structure

Mounting of PV panels in a vertical arrangement (vertically).



1. Essential tools for assembling the structure

- Allen spanner (ampoule spanner) size 6
- Cordless screwdriver with speed and torque control
- Hexagon socket wrench, size 6 for screwdriver head
- Open-end spanner, size 13, 15, 17 mm
- Ratchet spanner with socket size 13, 15, 17 mm
- Extension piece 100-120mm for socket spanners
- Rubber mallet
- Torque spanner, range 10-40 Nm

2. Bolt tightening torques:

- Possibility of using the structure in wind and snow zones in accordance with the following standards: PN-EN 1991-1-3 and PN-EN 1991-1-4
- Before installing the structure, read the installation instructions for photovoltaic panels
- SAM8x screws... E and NUTS NRM8PV should be tightened with a torque of 12-14 Nm
- When twisting the SGKFM10x20 screw, hold the screw head in such a position that the filling locks on the walls of the hole in which the screw is mounted, and then with the help of a screwdriver tighten the screw slowly until it is blocked in the hole. In the final phase, you need to tighten the screwdriver with a torque of 42 Nm
- Tighten the SRM10x...F screws to a torque of 20 Nm

3. Specification of elements included in the structure E-VKRN

Nr	Name	Product symbol	Purpose in construction
1	Channel bar	CMP41H41/...MC	Support Profile
2	Channel Connector	LC41H41MC	Channel connector
3	Side handle	BUF...	Side adhesive securing the panels
4	Intermediate handle	PUF	Intermediate adhesive fixing the panels
5	Screw	SAM8x...E	Screw
6	Screw	SRM10x30F	Screw
7	Rhombic nut	NRM...F	Rhombic nut
8	Spring washer	PS8E	Washer
9	Mushroom head screw	SGKFM10x20	Screw
10	Panel holder	APPMC	Panel support bracket



4. Montaż konstrukcji typ E-VKRN

Grounding pads of the PUP type should be placed at the mounting locations of PUF intermediate brackets..

If there is an even number of modules on the structure, grounding pads are installed every second row of panels.

In the case of an odd number of modules, washers should additionally be added under the extreme PUF holders to ensure that the last panel is also grounded.

Anchors should be selected depending on the type of substrate to which the structure will be mounted.

The APPMC bracket is used to prevent the panels from slipping. It should be fastened in the center of each panel using a bolt with a diamond nut, SRM10x30F.

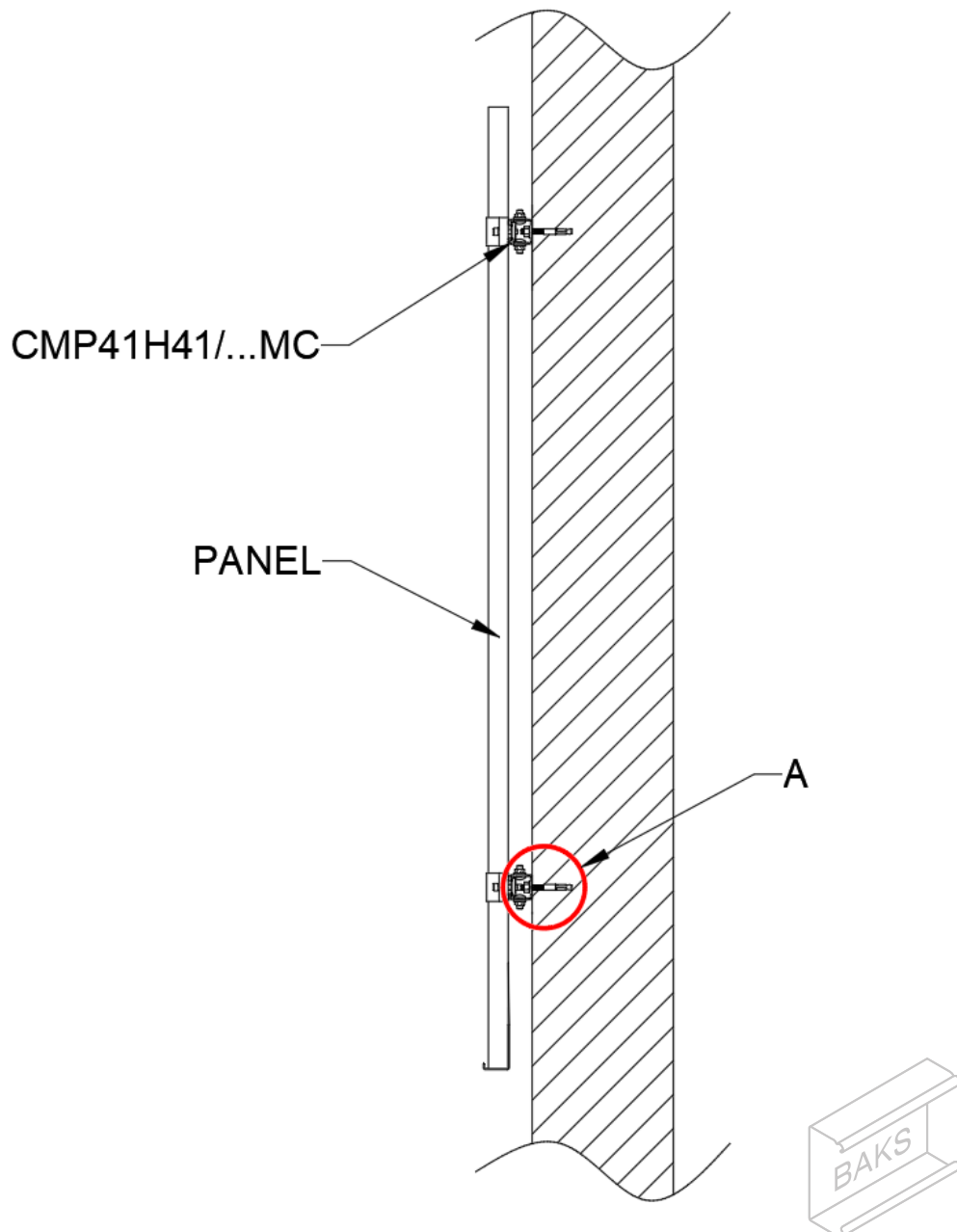

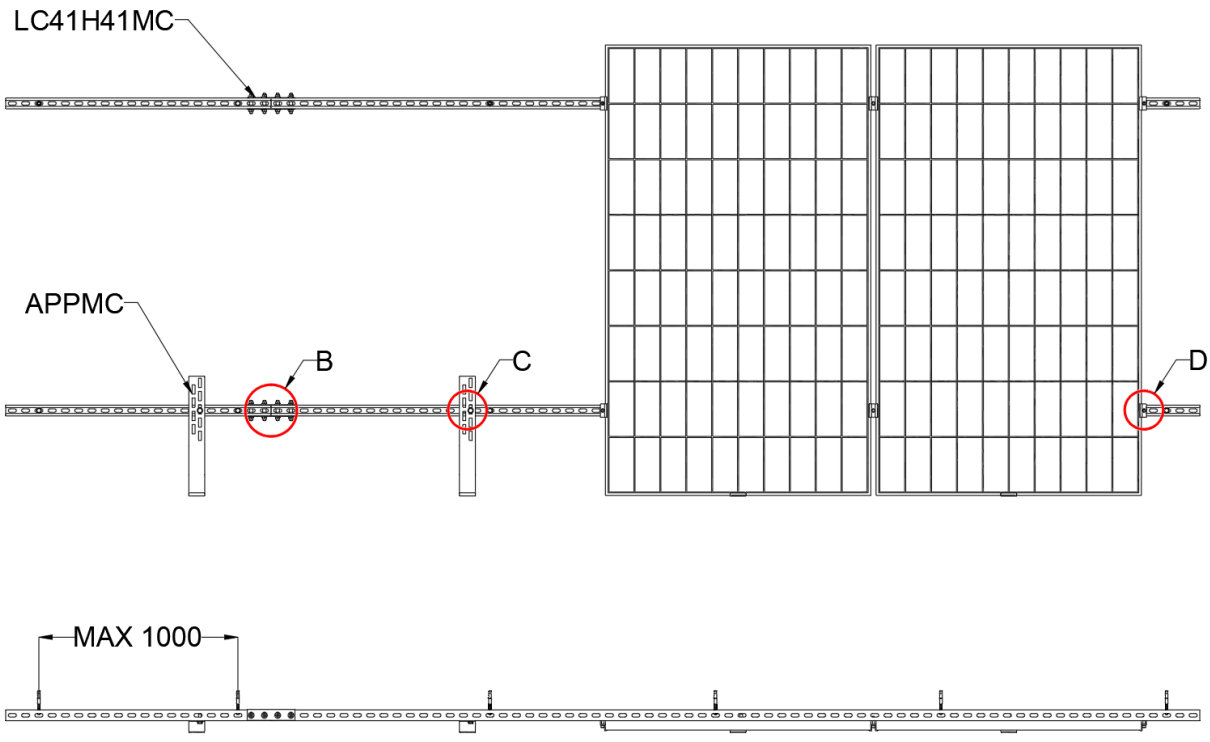

A (1:1)

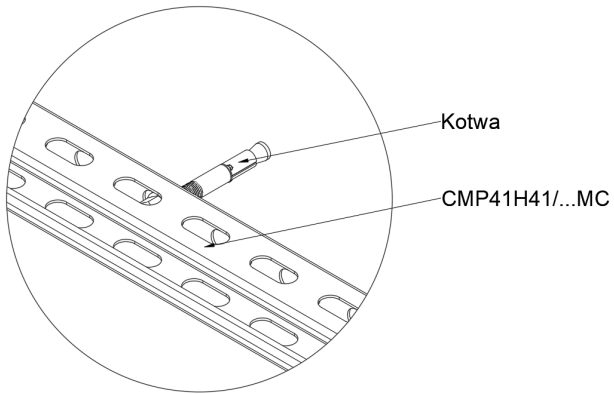

B (1:1)

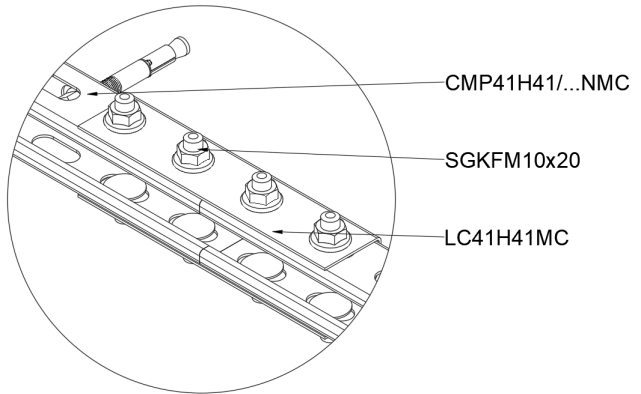

C (1:1)

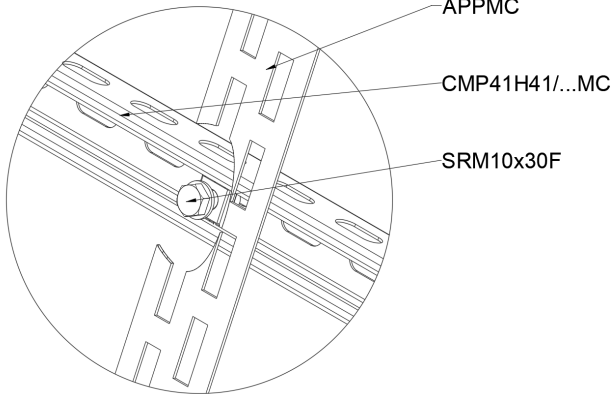

D (1:1)

