

W-H4G2 BI CONSTRUCTION ASSEMBLY INSTRUCTIONS

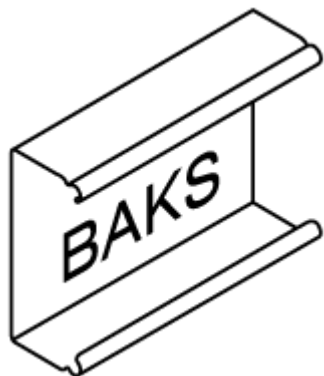

Manufacturer:

BAKS

Jagodne 5 Street

05-480 Karczew

Poland

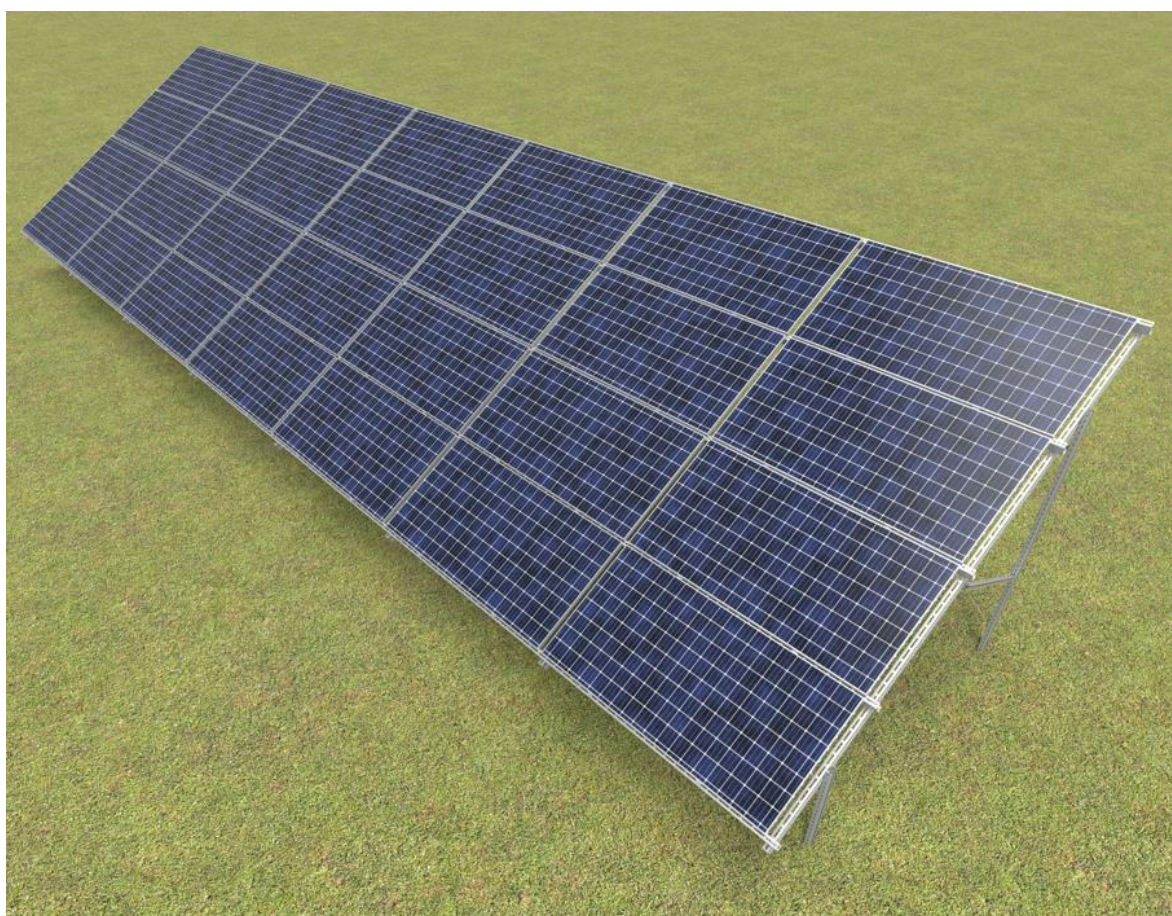

W – free-standing steel structure

H – horizontal arrangement of panels

4 – number of rows of panels

G – structure fixed to the ground by piles driven directly into the ground

2 – structure based on two support columns

BI – construction adapted to bifacial profiles



1. Essential tools for assembling the structure

- Allen spanner (ampoule spanner) size 6
- Cordless screwdriver with speed and torque control
- Hexagon socket wrench, size 6 for screwdriver head
- Open-end spanner, size 15 mm
- Ratchet spanner with socket size 15 mm
- Extension piece 100-120mm for socket spanners
- Rubber mallet
- Torque spanner, range 10-45 Nm

2. General information

- Possibility of using the structure in wind and snow zones in accordance with standards: **PN-EN 1991-1-3** and **PN-EN 1991-1-4**.
- Before assembling the structure, read the installation instructions for the photovoltaic panels
- It is recommended that connection of BDFCH... profiles to CWC100H50 profiles, CWCR100H50 profiles to CWC100H50 profiles and BUF... to CWC100H50 profiles should not be placed on the last (outermost) holes.
- Each CWC100H50 and CWCR100H50 profile must have at least 2 support points
- The depth of penetration of the profiles into the ground, the dimensions of the concrete pour hole and the dimensions of the foundation for anchoring the structure should be determined by an authorised constructor for the particular installation.
- If the panel mounting area does not coincide with the profile perforation, an adjustment must be made at the channel joint or an intermediate bracket type UPP...MC must be used.
- The grounding washer for the panel (PUP) is placed under the intermediate brackets of the panels. A single washer has the ability to ground two adjacent panels.
- Cutting of workpieces is only permitted with slow-running sabre saws and hand saws with high-grade steel tools, in order to avoid excessive heat build-up in the material.
- The cut edges must be unconditionally protected - sanded with sandpaper, cleaned and degreased again, protected with a minimum of three coats of zinc paste after drying.
- Bracing connecting successive frames should be placed at a maximum of every 4th field of the structure.
- Screw **SAM8x...E** and **NRM8PV** nut to a torque of 12-14 Nm.
- When tightening the **SGKFM10x20** screw, hold the head of the screw with your hand in such a position that the underlay locks onto the walls of the hole in which you are installing the screw, and then, using a screwdriver, tighten the screw slowly until it locks into place. At the final stage, tighten the screw with the screwdriver to a torque of 42 Nm.



3. Summary of components of the W-H4G2 BI construction

(Construction kit does not include tools)

No.	Product	Name of product	Designation in construction
1	Support Channel	CWT70H50/...NMC	Front and rear support pillars
2	Channel Connector	LCT70H50NMC	Support column connector
3	Rod Hanger	WPTCM	Bracing no 2
4	Threaded rod	PGM6/...E	Bracing no 2
5	Profile	BDFCH120/...NMC*	Rafter
6	Support Channel	CMP41H41/...MC	Bracing no 1
7	Channel Connector	LCJ70MC	Connector for bracing no 1
8	Support Channel	CWC100H50/...NMC	Purlin
9	Channel Connector	LCTW100H50MC	Purlin connector
10	Side Holder	BUF...	Lateral clamp for fixing panels
11	Middle Holder	PUF	Intermediate clamp for fixing panels
12	Grounding Washer	PUP	Panel earthing
13	Screw	SAM8x...E	Panel fixing screw
14	Spring Washer	PS8E	Head washer SAM8x...E
15	Screw set	SGKFM10x20PV	Screw + flange nut
16	Washer	PW10F	Washer
17	Channel Nut	NRM8PV	Clamp mounting nut

Table 1 Summary of components

*For panels wider than 1250 mm, the BDFTH120/...NMC profile can be used

4. Installation sequence:

- 1) Mounting of the **CWT70H50/...NMC** front and rear support pillars according to the information in Tables 3 and 4, in accordance with the "L1" and "L2" values indicated therein, taking into account their orientation with respect to the directions of the world as shown in Drawing No. 6.
- 2) Installing the **BDFCH120/...NMC** profile to the anchored support columns (detail 1; 2)
- 3) Assembly of bracing No. 1 (detail 3; 4)
- 4) Assembly and joining of the longitudinal profiles under the panels (detail 6; 7)
- 5) Assembly of bracing No. 2 (detail 5)
- 6) Installing the fastening clamps for the panels (detail 8.1; 8.2 ; 9)



Construction variant A

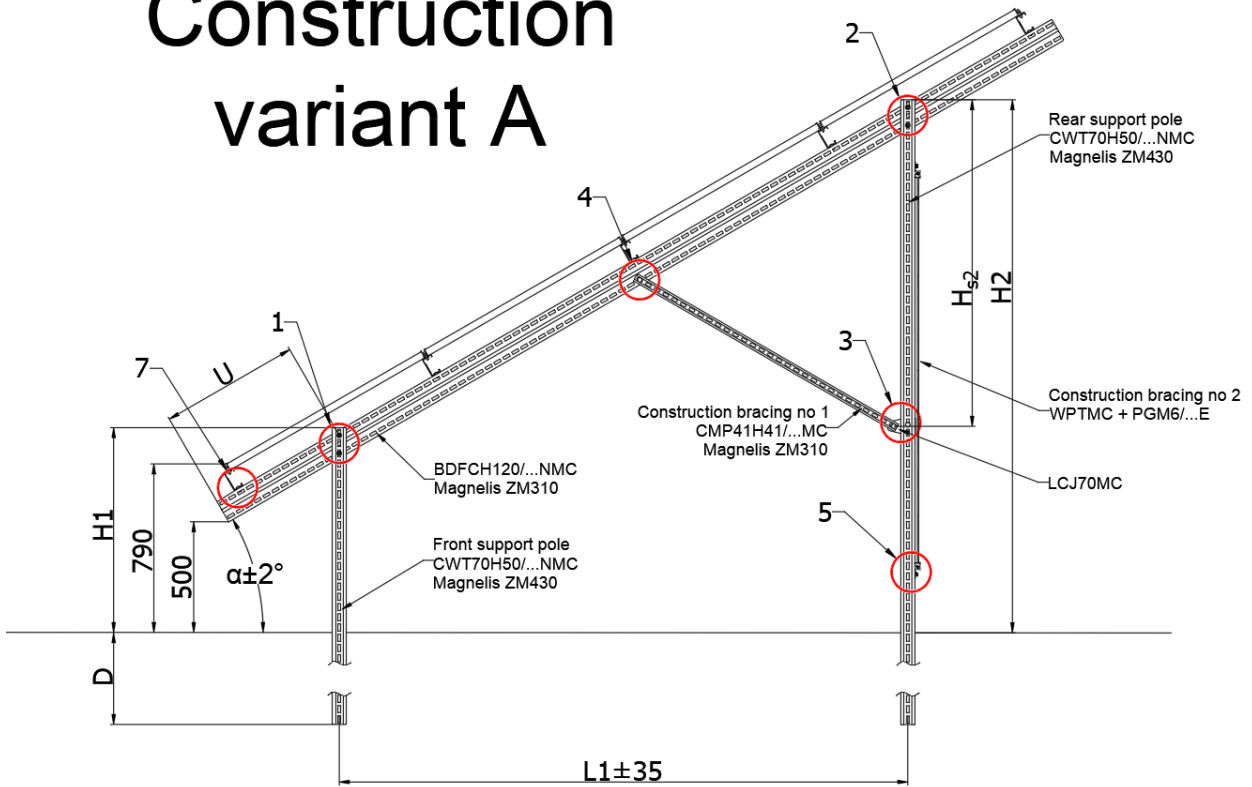

Construction variant B

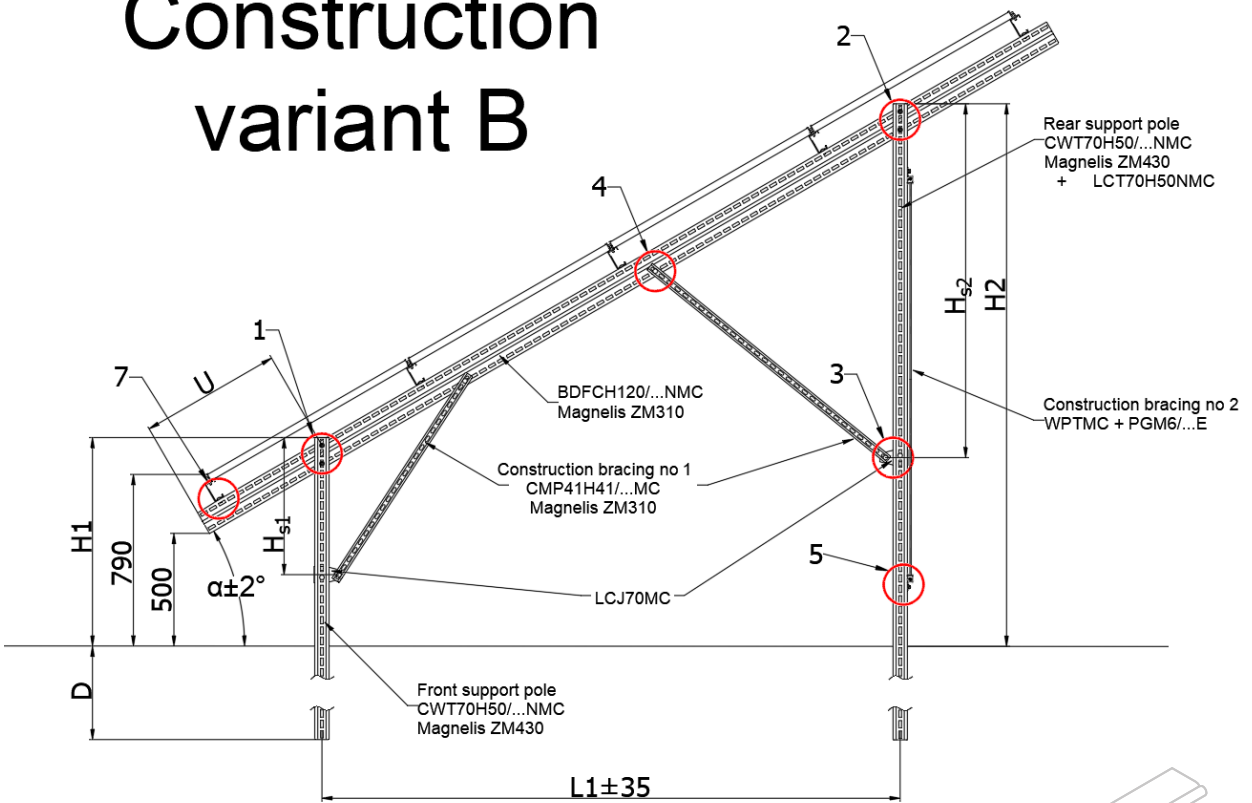

Fig. 1 Side view of the structure



Angle of structure „ α ”	Front support pillar	Front support pillar	Rafter	Brace No. 1
Panel width from 950 to 1000mm Construction variant A				
25°	CWT70H50/3NMC	CWT70H50/4,4NMC	BDFCH120/4,4NMC	CMP41H41/1,5MC
30°	CWT70H50/3NMC	CWT70H50/4,4NMC	BDFCH120/4,4NMC	CMP41H41/1,5MC
Panel width from 1000 to 1100mm Construction variant A				
25°	CWT70H50/3MC	CWT70H50/4,4NMC	BDFCH120/4,8NMC	CMP41H41/1,5MC
30°	CWT70H50/3MC	CWT70H50/4,4NMC	BDFCH120/4,8NMC	CMP41H41/1,5MC
Panel width from 1100 to 1250mm Construction variant B				
25°	CWT70H50/3NMC	CWT70H50/4,4NMC	BDFCH120/5,4NMC	CMP41H41/1,2MC + CMP41H41/2,2MC
30°	CWT70H50/3NMC	CWT70H50/3NMC CWT70H50/2NMC	BDFCH120/5,4NMC	CMP41H41/1,2MC + CMP41H41/2,2MC
Panel width from 1250 to 1300mm Construction variant B				
25°	CWT70H50/3NMC	CWT70H50/4,4NMC	BDFTH120/6NMC	CMP41H41/1,2MC + CMP41H41/2,2MC
30°	CWT70H50/3NMC	CWT70H50/3NMC CWT70H50/2NMC	BDFTH120/6NMC	CMP41H41/1,2MC + CMP41H41/2,2MC

Table 2 Lengths of construction elements depending on panel size

If it is necessary to connect the support columns, use the LCT70H5NMC connector and 12 SGKFM10x20 bolts for the connection (extension).

The longer of the channel bars assigned to the rear support column should be anchored to the required depth, the shorter being its extension above the ground.



Angle of structure „ α ”	Distance „L1”	Height				Distance „U”
		„H1”	„H2”	„H _{S1} ”	„H _{S2} ”	
Panel width from 950 to 1000mm Construction variant A						
25°	2820	870	2180		1520	580
30°	2520	970	2410		1620	690
Panel width from 1000 to 1100mm Construction variant A						
25°	2960	950	2330		1520	780
30°	2830	970	2600		1620	690
Panel width from 1100 to 1250mm Construction variant B						
25°	3370	950	2530	640	2340	780
30°	3450	970	2960	670	2440	690
Panel width from 1250 to 1300mm Construction variant B						
25°	3370	950	2530	640	2340	780
30°	3450	970	2960	670	2440	690

Table 3 Structure dimensions on the angle of inclination of the structure and the size of the panels

The dimension „D” is determined by a competent person depending on the quality of the soil.



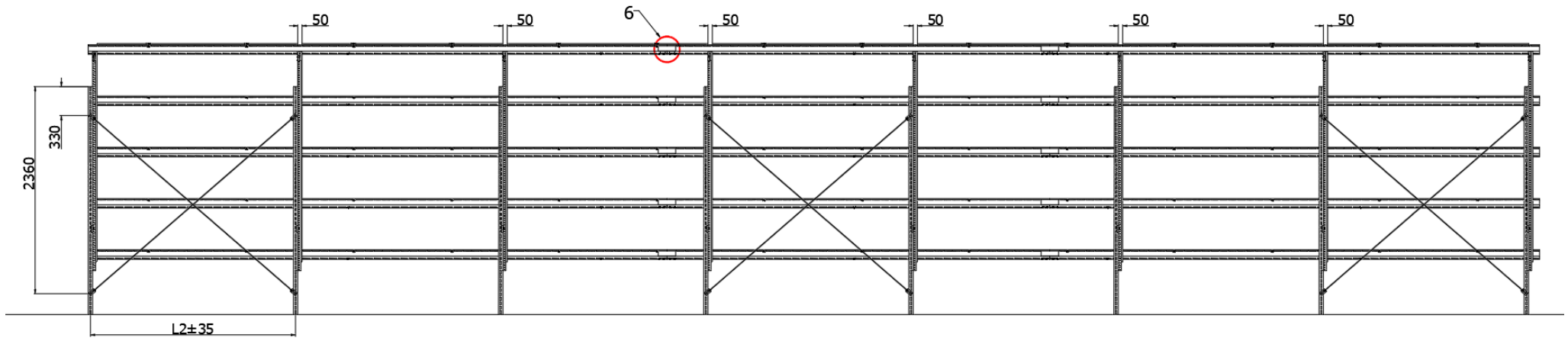

Fig. 2 View of the structure with bracing spacing No. 2

The dimension L2 is closely related to the size of the panels used in the construction. It must be calculated using the following formula:

$$L2 = (\text{panel width} + 50\text{mm})$$



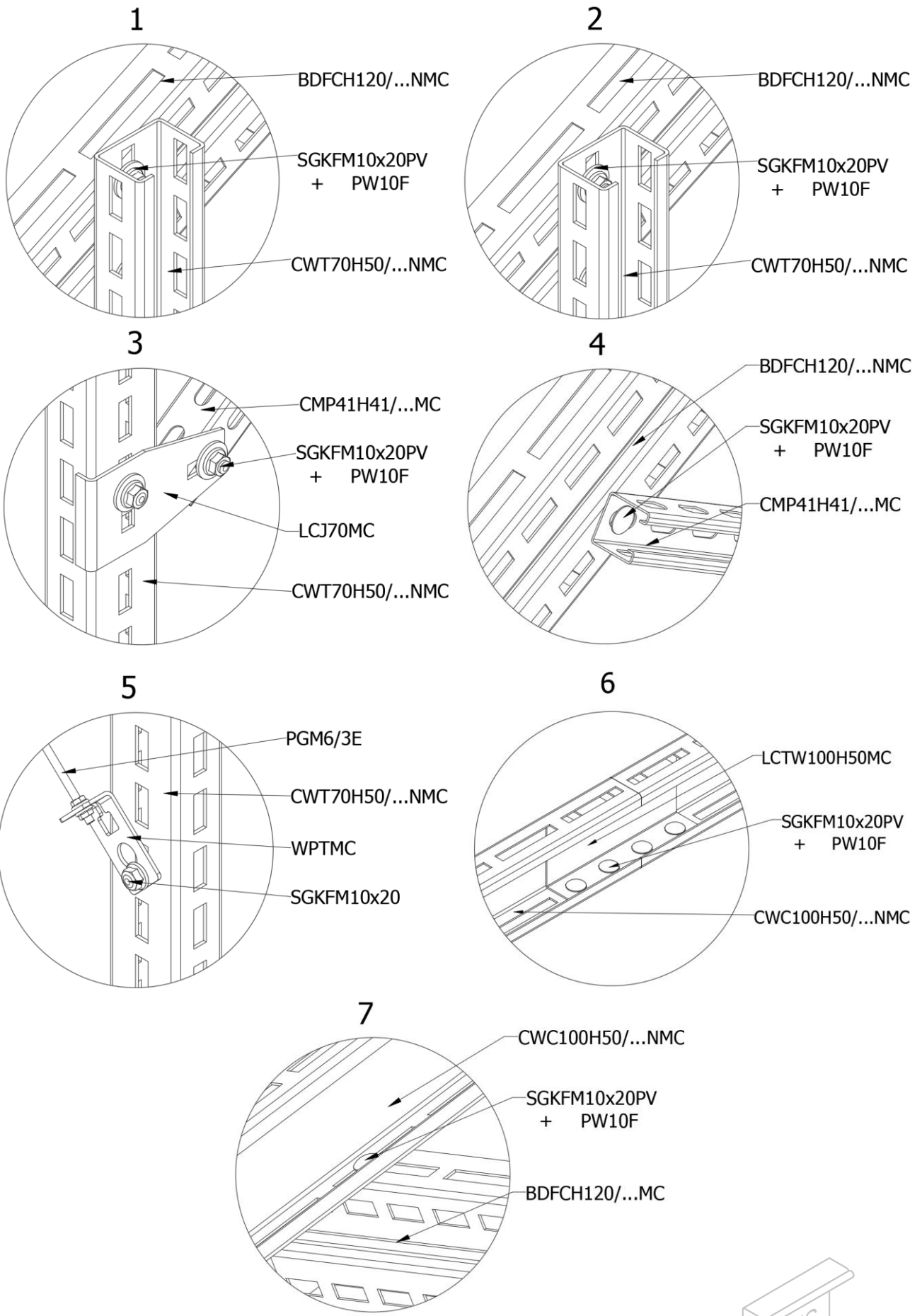

Fig. 3 Details of connecting individual components



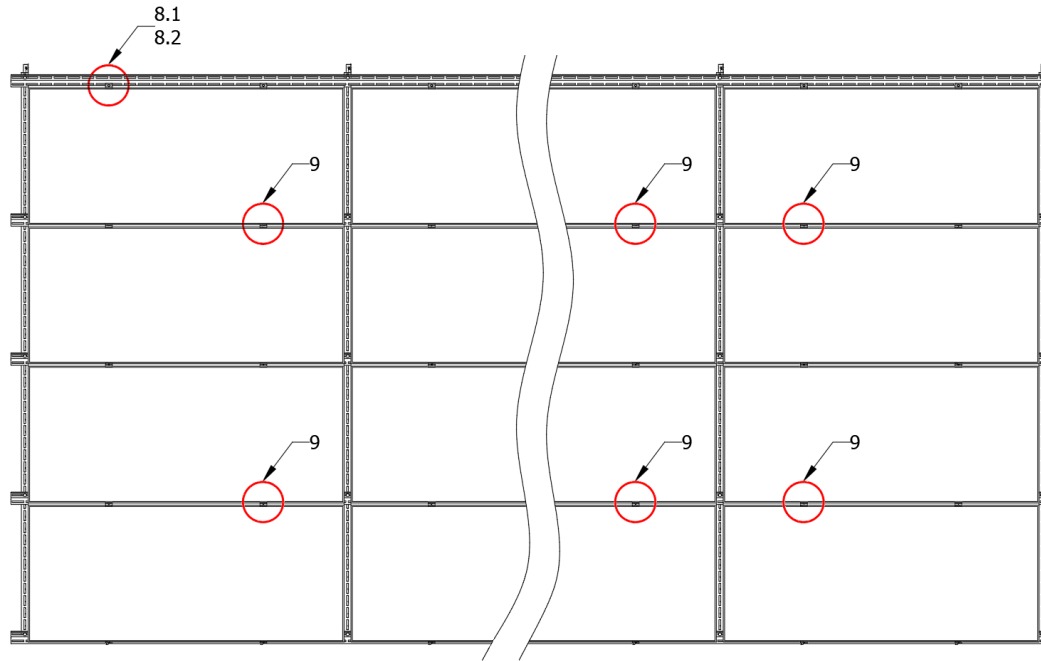

Fig. 4 Top view of the structure

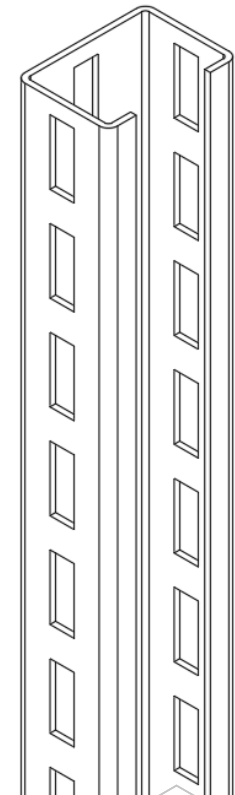
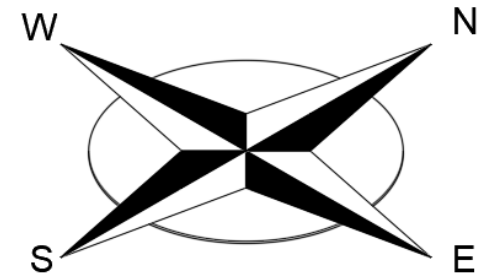

Fig. 6 Orientation of support column

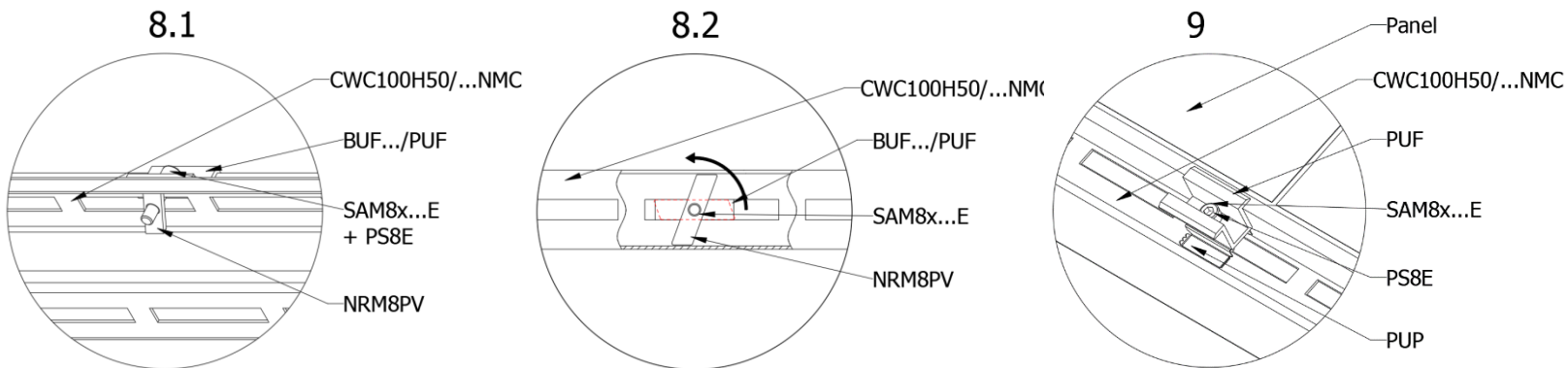

Fig. 5 Detail of assembly of the clamps together with the earthing washer and locking of the channel nut