



The BAKS company was established in 1986. We are now a leading manufacturer of support systems for power and telecommunications industry as well as pneumatic and water cables, and other sectors, active in Poland and throughout Europe.

Due to the increasing demand in the RES sector, BAKS company also offers a wide range of solutions for the installation of photovoltaic panels, both for free-standing structures and for flat and sloping roofs. Systems mounted directly to the building elevation and balcony railings are available as well. Using the latest technology, an experienced team of specialists and investments in modern machines and equipment (punching machines, profiling lines, welding robots, specialist laser cutting machines, bending brakes, powder paint shop, hot dip galvanizing plant) allowed us to achieve the highest standards.

Our products quality is confirmed by following certificates and reports:

- Certificate for mounting systems for photovoltaic panels, certificate no.: TM61000362.001 issued by TÜV Rheinland
 - TÜV certificate for Factory Production Control in compliance with EN 1090
 - The product certificate in accordance with PN-EN 61537:2007 issued by TÜV Rheinland, concerns product safety and the strength of the cable tray systems in the catalogue (the strength values given in the catalogue contain a safety factor of 70%, which means that they are 70% stronger than the strength values given in the catalogue).
- It also confirms the electrical continuity of the cable tray system. This standard is harmonised with the EU Low Voltage Directive up to 1 kV.
- Reports from strength calculations of available PV structures made by authorized construction offices
 - VDE certificates confirming electrical continuity of BAKS systems
 - TÜV ISO 9001:2015 certificate confirming that the quality of products designed and produced by BAKS comply with ISO 9001:2015
 - Certificate confirming the implementation of the environmental management system - ISO 14001:2015
 - Welding qualification certificate EN 1090-2:2018
 - Wind tunnel test reports are available for free-standing structures and flat roof systems

We are a recognized and valued partner in our field. Participation in various projects is a proof of that - please find some examples below in Poland:

- PV farms throughout Poland within one investment – 33x1MW
- PV farms throughout Poland within one investment – 31x1MW
- PV farm in Dziewoklucz – 20MW
- PV farm in Kokoszczyń – 19MW
- PV farm in Lubrza – 18MW
- PV farm in Zwierzyn – 10MW
- PV farm in Cychry – 8,5MW
- PV farm in Batorowo – 7MW
- PV farm in Góra I,II,III,IV – 6MW
- PV farm in Duszniki – 6MW
- PV farm in Krotoszyn – 6MW
- PV farm in Zdrójki Prawe – 5MW
- PV farm in Nekla – 4MW
- PV farm in Kamiennej Górze – 3MW
- PV farm in Bierutowie – 2MW
- PV farm in Bronikowo – 2MW
- PV farm in Hellena Opatówek – 2MW
- PV farm in Długa Wieś Druga – 2MW
- PV installations on flat and sloping roofs throughout Poland with a total power of 0,5GW (Kronospan - 2,2MW, Wielton - 5,5MW, Hitachi Energy Łódź - 0,57MW)
- PV installations for sloping roofs, including the supply of structures for projects carried out by IKEA
- Investments throughout Poland made through the electric wholesalers cooperating with us
- PV farm in Mechlin – 2MW
- PV farm in Chudek – 1MW
- PV farm in Krośnie – 1MW
- PV farm in Karsy – 1MW
- PV farm in Mysłibórz – 1MW
- PV farm in Boleszkowice – 1MW
- PV farm in Lopiwno – 1MW
- PV farm in Retków – 1MW
- PV farm in Olchowa – 1MW
- PV farm in Skorowitach – 1MW
- PV farm in Jarostach (for the needs of the IKEA logistics center) – 0,8MW
- PV farm in Osiemborowie – 0,8MW
- PV farm in Kosutach – 0,8MW
- PV farm in Braszewice – 0,8MW
- PV farm in Teodory – 0,7MW
- PV farm in Bukowina Cycowska – 0,6MW
- PV farm in Biała - 2,7MW
- PV farm in Świdnica - 0,5MW

Abroad::

- PV farm in Stelpe (Latvia) - 73MW
- PV farm in Możejki (Lithuania) - 42MW
- PV farm in Halamjugra (Hungary) – 24MW
- PV farm in Pussi (Estonia) – 7,62MW
- PV farm in Vagari Yingli (Estonia) – 5,88MW
- PV farm in Rapla (Estonia) – 5,27MW
- PV farm in Nowoukraince (Ukraine) – 5MW
- PV farm in Rabase (Estonia) – 4,51MW
- PV farm in Marjamma (Estonia) – 3,7MW
- PV farm in Vagari (Estonia) – 2,78MW
- PV farm in Pussi II (Estonia) – 1,24MW
- PV farm in Joeveere (Estonia) – 1,12MW
- PV farm in Janikese Hundi (Estonia) – 0,56MW

In order to meet the needs of our Customers, the production line has been modernized, which makes it possible to realize our Customers' individual projects according to the provided documentation. Caring for the Customers' needs by providing the highest quality products, maintaining low prices, as well as professional logistics have earned BAKS the trust of its Customers.

**BAKS elements of PV structure systems are available in electrical wholesalers i.a. all over Poland.
We invite you to purchase photovoltaic systems produced by us.**

Kazimierz Sielski



I. General Terms and Conditions of the Warranty

1. BAKS („Producer“) hereby warrants to the Buyer that the product is free of material and workmanship defects.
2. A defect in the material and workmanship shall be understood as a defect causing the product to operate in a manner which is inconsistent with the Producer’s specification.
3. The warranty shall cover in particular: mechanical strength of the goods and corrosion resistance of the zinc coating, the coating of powder-coated components and components made from stainless metal sheets.
4. The warranty covers damage and defects caused by reasons solely attributable to the Producer, such as breaking and bending of the structure, flaking of the protective coating.
5. The Buyer shall be understood as the entity which made a purchase directly from the Producer.
6. The Producer shall remove, free of charge, any defects in the material and workmanship discovered during the warranty period on the terms and conditions stipulated herein, by fixing the product or replacing it with a product which is free of any defect. The Producer has discretion with regard to the choice of the method of repair.
7. The warranty period is 10 years from the date of sale for the corrosiveness class C1, C2 or C3, provided that the user of the PV installation carries out maintenance of photovoltaic-components at least once a year.
8. In justified cases, the period of warranty may be extended by the Buyer’s request following the arrangement of the conditions of storage, use and maintenance of the Products with the Producer. Any extension of the warranty period shall be certified in writing, otherwise it shall be null and void.
9. This warranty shall be effective on condition that the product is used for purposes it was designed for, in line with the Producer’s specifications, technical and environmental conditions.
10. Neither the Buyer nor any third parties shall have any claims for damages due to any defects arising from a failure of the Product. The only liability of the Producer under this warranty shall be the repair or replacement of the Product for one which is free of any defect, in accordance with the terms and conditions hereof.
11. The Producer shall be liable to the Buyer only for physical defects arising from causes existing in the purchased Product itself.
12. In order for the warranty to be valid and effective, the following conditions must be satisfied.

Transport

Products shall be transported in dry, covered means of transport in such a way that the Products are protected against moving, mechanical damage and exposure to elements. Units of load shall be placed in the means of transport one next to another tightly and fixed to prevent them from moving. The cargo should be fixed with transport belts to prevent damage to the components.

Storage of products

Products should be stored in dry, clean, ventilated storage rooms free from any chemically reactive vapours and gases. Products must be secured from getting wet or damp. If zinc-coated elements get wet or damp, remove them from wet packaging as soon as possible, disassemble them and allow them to dry, then re-assemble them and store in a dry and airy room that ensures protection from precipitation. Products must be stored on pallets, in containers or on specially designed bases (they should not be put directly on concrete, floor of ground).

Storage in inappropriate (humid) conditions may lead to condensation appearing between the surface of zinc coated or painted elements, or ones made from stainless steel. If zinc-coated elements are exposed to humidity, so called white corrosion (white-greyish stains) may appear, which does not affect the quality of the zinc coat and does not provide grounds for claiming the warranty. Products made from stainless steel or painted products may be protected with film, which must be removed without delay upon delivery. Leaving the protective film on products that are painted or made from stainless steel during storage in high temperature and high exposure to sunlight, may lead to chemical reactions causing the film to be embedded in the packaged elements. As a result of such reaction, it will be impossible to remove the film without damaging the surface of the products. For the duration of storage and assembly of the elements, they must be protected against contact with lime, cement and other alkaline construction materials. The products shall be protected from splashes from grinding and welding, repair or construction works as they may leave slight discolourations which may be difficult to remove. The transport, storage and assembly of the products must be performed in an environment consistent with the appropriate corrosiveness class based on the PN EN ISO 12944:2001 standard (more information in the table).

In case of not conforming to the regulations, claims shall not be accepted!

The products must be stocked indoors, under roof and in a dry environment. Do not allow humidity nor wetting the products!

Installation Proper selection of products and the correct method of installation are essential to the proper functioning of the products. Installation must be carried out in accordance with the manufacturer’s instructions and/or indications.



Protection and maintenance of Magnelis coated components according to EN 10346:2015-09

The most common cause of defects in zinc coatings is improper handling of the product during storage and installation:

- products in storage (i.e. in original BAKS packaging) should be stored in dry and ventilated rooms;
- during storage, protect against changes in humidity and temperature which may cause condensation;
- if it is necessary to keep the products in the open air for a short period of time, ensure moisture removal. Use a cover ensuring breathability;
- in case of wetting of galvanised elements, the phenomenon of so-called white corrosion may occur, which does not reduce the protective layer and does not impair the anti-corrosive properties of the coating, but does impair the appearance and aesthetics of the components. However, over time, if the components have not been dried, there is a complete reduction of the zinc coating to the point of corrosion. If wetting of galvanised components and white corrosion occurs, proceed as follows procedure:
 - ✓ remove outer packaging immediately,
 - ✓ arrange them so that the individual elements do not come into direct contact with each other (e.g. by interlaying the layers with narrow galvanised steel, plastic or aluminium profiles),
 - ✓ wash with running water if there are any solid contaminants (soil, wet cardboard packaging etc.),
 - ✓ dry to prevent moisture build-up or leave in an open, dry, ventilated area to dry,
 - ✓ store in a dry room.
- Rough edges that have been created whilst cutting and drilling for the installation, should be carefully deburred and degreased, and contaminants (dust, oil, grease, traces of corrosion) removed. Repairs should be carried out by painting with zinc-rich primer, zinc paste or a technically equivalent material. The thickness of the paint coat should be at least 30 µm thicker than the required local thickness of the zinc coating.

Protection and maintenance of painted elements

The most frequent cause of defects in paint coatings include: mechanical defects (scratches, chips) and cleaning with chemical agents. Therefore the following rules must be observed:

- pay particular attention during assembly to avoid scratching and chipping
- use protective tapes (e.g. painter’s tapes) when cutting the element to size
- clean the product at least twice a year
- clean with delicate, non-abrasive fabrics and clean water with pre-tested detergent
- do not clean the coating with steam jets
- if you intend to clean the product with other cleaning agents than water, test the effects of the agent before cleaning the surface. If you notice any undesirable effects, do not use the tested cleaning agent
- do not use any highly-acidic or highly alkaline cleaning agents (including ones containing detergents)
- do not use salt or chemical substances meant for removing ice in the vicinity of painted surfaces

Protection and maintenance of Magnelis or equivalent coated components according to EN 10346:2015-09

- storage, assembly and operation of the structure will take place in an environment with the corrosive aggressiveness category specified in the table below for the given warranty period and the given zinc coating agreed in advance with the manufacturer,
- during the storage period, prior to assembly, structural components shall be stored on bases in such a manner as to prevent contact with the substrate, accumulation of precipitation and any other incidental deposits. Pre-packed construction elements must not be exposed to moisture. In the event of dampness the package, the elements must be unpacked and spread out until they are fully dry,
- elements damaged during assembly must be replaced with new, defect-free elements at the purchaser’s expense,
- the purchaser shall, upon completion of the assembly of the structure, at his own expense, carefully inspect the protective coating and carry out a complete preservation by cleaning galvanised surfaces with neutral chemical agents to remove any remaining impurities (chemical residues, grease, oily substances and other impurities which may cause damage to the anti-coatings). Which may cause damage to the anti-corrosion coatings). After cleaning the structure, the purchaser is obliged to document with a photographic image any corrosion spots that may have occurred and to send the documentation to the manufacturer in order to establish the damage caused to the product. The purchaser is obliged to send the report to the manufacturer within 6 months of the purchase and immediately after completion of the installation under risk of loss of guarantee. Products made of Magnelis material or equivalent material may, in the initial phase of use, at the edges of the material or at the edges of the openings, become covered with a thin, superficial layer of red corrosion. In the course of time, the coating will self-regenerate, i.e. oxides of alloying substances will form on the surface. Over time, a self-regenerating effect occurs, i.e. the formation of oxides of the Magnelis material or equivalent alloying agent, which form a tight protective and corrosion-repellent layer between the steel and the atmosphere. Detailed information on the Magnelis material or equivalent is available on request



Protection and maintenance of stainless steel and aluminium components

The treatment method and the correct choice of material grade for the prevailing atmospheric conditions is an extremely important factor that affects the quality of the surface during the servicing process. The corrosion resistance of stainless steel can be maintained by cyclic surface cleaning and further improved by chemical surface treatment - passivation. The most common cause of the appearance of „corrosion“ spots is:

- contamination of the surface by particles of iron, black steel (splintering during grinding cutting, grinding, welding),
- scratches that occur at the point of friction with a sharp component made of mild steel,
- improper storage and transport,
- inappropriate choice of material grade or product protective coating for the atmospheric environment in which it is used.

Storage of galvanised, galvanised and lacquered products - made of stainless/acid-resistant steel, aluminium

Superficial dark discolourations occurring locally on products made of stainless/acid-resistant steel or aluminium do not affect the quality and functionality of the product and are therefore not subject to complaint. During the mechanical processing of stainless/acid-resistant steel or aluminium, interference with the passive layer of the component occurs causing minor damage to the tension surface of the passive layer. Upon contact with oxygen, discolouring substances precipitate in the places of minor surface defects, causing discolouration. This process does not occur deep into the material. Further structure remains intact. Such phenomena can occur under any conditions both during transport, storage and use (especially in humid conditions the precipitation of discolouring substances on the surface of the material is accelerated). Damage to the passive coating most frequently occurs during product assembly (e.g. by impacts, abrasions, scratches) or as a result of the use of improper tools and abrasives. Under assembly conditions, strongly adhering deposits and tarnishes can form on the products, which contribute to the formation of stains, discolouration or tarnishing. These are harmless to the product and are usually cleanable. Stainless steel is characterised by the fact that it does not require additional corrosion protection after treatment. Nevertheless, maintenance and cleaning are required during the service life of the material in order to maintain the aesthetic appearance for a longer period of time. The frequency of cleaning and maintenance of the range depends on the conditions of use, and the degree of use. In the event of soiling on the products the coating must be cleaned and protected.

Cleaning and maintenance methods for stainless/acid-resistant steel and aluminium

The method of treatment and the correct choice of material grade for the prevailing atmospheric conditions is an extremely important factor that affects the quality of the surface during the service process.

- superficial discolouration and dust occurring during use can be removed with e.g. a cloth, suede leather or sponge;
- steel pads or wire brushes must not be used to scrub the products. They may leave fine particles of mild steel deposited on the surface of stainless steel or aluminium, resulting in discolouration or even corrosion of the material with deeper interference;
- localised discolouration from fingerprints, dust or rain can be easily and quickly removed by wiping the product;
- local dirt or grease marks, if they are minor, can be removed with water and a suitable detergent; for heavy dirt, use a special chemicals for cleaning and maintenance of stainless/acid-resistant steel or aluminium; alcohol-based cleaning agents are acceptable for cleaning (they do not affect the anticorrosive coating);
- in the event of iron particles on the elements as a result of construction work (e.g. grinding, welding, scratching with a sharp particles from construction work (e.g. grinding splatter, welding, scratching with a sharp mild steel component), they must be removed immediately. These particles will be susceptible to corrosion, which will have a destructive effect on the passive layer of the stainless steel component and may lead to corrosion of the material. Deposits with iron particles should be removed mechanically or with dedicated chemical agents;
- special care must be taken during installation (stainless steel products should preferably be installed in the last stage of the work). In the case of deeper damages and the appearance of so-called corrosion pits, it is necessary to etch the area with acid and protect it with a passivating agent. Please note that the etching process may cause irreversible loss of the aesthetic appearance of the assortment;
- after cleaning, it is recommended to carry out an additional polishing process with a dry soft cloth;
- cleaning agents containing chlorides should not be used and the use of silver cleaners is forbidden.

The frequency of cleaning and maintenance work depends on the environment in which it is used, the degree of soiling and the operating conditions. Stainless steel products should be cleaned at least once every 12 months for minor contamination or at least once every 6 months for major contamination.

Treatment and maintenance steps in the event of signs of corrosion:

- **mechanical cleaning.** Clean areas with surface corrosion with abrasive fleece and wipe with a dry, clean cloth;
- **chemical cleaning.** Apply, e.g. with a brush, a thin and even layer of a suitable chemical agent to the cleaned surfaces. After approx. 5 min. (the time depends on the type of chemical used) wash off the chemical with a damp cloth. Rinse the cloth regularly in clean water or change to a clean one. Particular care should be taken to ensure that no other components in the vicinity of the parts to be cleaned are splashed. Then the damp surface should then be wiped dry with, for example, a soft cloth towel or paper.
- **passivation.** The cleaned dry surfaces should be treated with a passivation agent using a sponge or spray, so that a thin even protective layer is formed. The above steps should be carried out manually without using power tools. If there are other components under the products to be cleaned and there is a risk of splashing they should be covered, e.g. with thick painter's foil. To clean stainless steel, do not use grout remover products or substances which contain hydrochloric acid, bleach or silver cleaners

Do not use carbon steel wire brushes, steel cleaning wool, steel scouring pads.

II. Loss of warranty – applies to all BAKS products (including those made with Sendzimir galvanizing, Magnelis coating or equivalent, zinc-flake galvanizing, hot-dip galvanizing, stainless/acid-resistant steel, aluminium, painted products and others)

- The warranty does not cover:
 - mechanical damage and resulting defects, in particular damage to protective coatings caused during transport, storage, assembly, operation and maintenance;
 - damage resulting from installation and/or operation of the products under conditions or in a manner inconsistent with the manufacturer's specification (exceeding the permissible loads, damage caused by environmental conditions, etc.);
 - damage to products due to improper storage (mechanical damage, discolouration, stains, white corrosion);
 - damage caused by the use of salt and chemicals for de-icing in the vicinity of stored or installed products;
 - damage resulting from structural changes or the use of products contrary to their intended use;
 - damage resulting from the installation of products to concrete surfaces before the end of the concrete setting period, i.e. when 100% of the concrete strength has been reached and the cessation of emission of chemical secretions (installation on so-called fresh concrete);
 - damage occurring during transport using means of transport external to the Manufacturer;
 - failure to comply with the obligation to carry out periodic maintenance inspections, if required;
 - other damage resulting from improper use of the products;
 - damage resulting from adverse events (fire, inundation, damage resulting from acts of terrorism and war, etc.);
 - occurrence of payment arrears for the Product exceeding 90 days from the due date of the invoice.
- The warranty does not cover normal operational maintenance activities, such as cleaning and maintenance.
- Products installed at the destination must be subjected to periodic maintenance at intervals not exceeding 12 months consisting of removal of soiling (chemical residues, grease and oil residues and all other soiling which could damage the anticorrosion coating) and restoration of the coating. After maintenance, a report with full photo documentation showing the condition of the installation before and after the work is carried out must be sent to the manufacturer and after the works have been completed within 30 days of the completion of the maintenance under risk of voiding the guarantee. The report should indicate the products covered by the guarantee, the purchaser's details, proof of purchase no. the place where the products were installed. The report should be sent to: baks@baks.com.pl. Areas omitted from the report where corrosion appears cannot be the subject of a warranty claim.
- The cable route MUST NOT be used as a communication/transportation route, it is not allowed to walk on it and/or lay objects, e.g. during installation work, inspections, etc. Damage resulting from improper operation is not covered by the warranty.

III. Exercising of Warranty

- Defects discovered during the warranty period will be fixed free of charge by BAKS as soon as possible, after the relevant warranty claim is filed.
- Defects or damage to the product uncovered during the warranty period should be reported to the Producer without delay, in any case not later than 7 days after their discovery.
- The warranty procedure covers only complete, verifiable products, free of any mechanical defect or damage caused by external factors.
- The following conditions must be satisfied in order for a claim under the warranty to be handled:
 - ✓ the product's name, catalogue number, purchase date, the number of the packing list document or the purchase invoice,
 - ✓ details of the damage to the products and the surroundings in which it occurred, with further information about the occurrence of defects in the product, including pictures of the defective products and the surroundings in which they are mounted and stored.
- Having acknowledged the claim, the Producer shall decide how the claim is to be satisfied.
- The Producer reserves a right to conduct an on-site inspection in the place where the faulty product was mounted.
- The Producer reserves a right to put the warranty procedure on hold if the Buyer is in arrears with the payment for invoices for longer than 14 days.

Disclaimer: BAKS has a policy of continuous product development and reserves the right to alter or amend specifications, as necessary, without prior notice presented in this publication. This catalogue is designed to provide only preliminary technical information which refers to standard products manufactured by BAKS.



I. Information about the materials and protective coatings of materials of which BAKS products are made.

Table of corrosivity classes according to PN-EN ISO 12944-2:2018-02 for hot-dip galvanized elements PN-EN ISO 1461:2011

Corrosivity classes	C1 very low	C2 low	C3 medium	C4 high	C5 very high (industry grade)	CX extreme (marine)
Reduction in protective coating [µm/year]	< 0,1	> 0,1 to 0,7	> 0,7 to 2,1	> 2,1 to 4,2	> 4,2 to 8,4	> 8,4 to 25
Examples of typical environments for moderate climate (for reference only)	Indoors: heated buildings with clean atmosphere, e.g. shops, offices, schools, hotels Outdoors: –	Indoors: non-heated buildings in which condensation may occur, e.g. sports halls, warehouses Outdoors: atmospheres with a low degree of pollution - mainly rural areas	Indoors: manufacturing premises with a high level of humidity and some air pollution, e.g. food processing plants, laundries, breweries, dairies Outdoors: urban and industrial atmospheres, moderate sulfur dioxide pollution; coastal areas with low salinity	Indoors: chemical plants, swimming pools, ship repair yard Outdoors: industrial zones and littoral areas of medium salinity	Indoors: buildings or areas with almost constant condensation and high pollution Outdoors: industrial areas with high humidity and an aggressive atmosphere as well as littoral areas with high salinity	Indoors: industrial areas with extreme humidity and aggressive atmosphere Outdoors: coastal areas with high salinity and industrial areas with extreme humidity and aggressive atmosphere and subtropical and tropical atmosphere
----- [W] - Indoors [Z] - Outdoors						

Material table

Material	Type of coating	Coating properties																												
Steel	[MC] MAGNELIS PN-EN 10346:2015-09	The innovative MAGNELIS coating is a composition of pure zinc with magnesium and aluminium. Such composition provides excellent corrosion resistance even in harsh environmental conditions. Such coating is less susceptible to white corrosion in comparison to pure zinc. The Magnelis coating naturally has dark grey colour and smooth unspangled aspect. Magnelis has the ability to regenerate itself at the cutting edges - in addition to the standard cathodic protection comparable to that of a zinc coating, Magnelis protects the exposed cutting edges from corrosion with a thin zinc coating with magnesium. Depending on the environment in which Magnelis is used, its use allows a significant, 2-4-fold reduction in coating weight compared to hot-dip galvanizing, additionally providing better anticorrosive properties and cost effectiveness.																												
	[F] Hot-dip galvanized PN-EN ISO 1461:2011	Completely processed parts (after cutting, bending, welding, etc.) are dipped in molten zinc at a temperature of approx. 450-460 °C. The process protects steel from corrosion. The process involves a complicated technology based on diffusion. The process involves zinc atoms penetrating into the outer steel surface to create a new iron-zinc alloy on the surface. Once the element is out of zinc bath, a coating of pure zinc is obtained on its surface. Depending on conditions during zinc coating (dipping time, cooling, quality of basic material surface, chemical composition of the basic material, etc.), the surface of the zinc coating can range from glossy light grey to matt dark grey; however, this does not affect quality of the protective coating. There may be the effect of humidity resulting in white stains on the surface. This is zinc hydroxide, also known as white corrosion, which does not affect the quality of the protective film, but it has an effect on aesthetic quality of the product. All types of cable trays and cable ladders as well as load bearing elements, which are zinc-coated by hot-dipping, are recommended for outdoor use, where vapours of chemically aggressive substances are present. Products undergoing hot-dip galvanizing process are mostly used in environments of category C3 and C4, where high humidity is present (basements, garage rooms, boiler rooms, etc.), and corrosion categories C5 and CX, where vapours of chemically aggressive substances occur, e.g. sea water, fumes from coal burning, etc. (shipyards, chemical / oil / gas processing plants, mines)..																												
	[FP] Zinc flake coating PN-EN ISO 10683:2014-09	The base coating is applied in the form of zinc and aluminium flakes. The flakes react with the steel surface to form a well-adhering, conductive and non-toxic zinc-aluminium coating after heat holding. This method is characterised by very high corrosion resistance – up to 1,000 hours in a salt chamber acc. to ISO 9227, till occurrence of red corrosion. The method is accepted worldwide by leading manufacturers in the automotive industry, power sector and aviation; it is commonly applied for threaded items due to problem-free screwing elements together.																												
Material	Material/coating type	Material/coating characteristics																												
Stainless steel	[E] 1.4301 (304) 1.4016 (430) 1.4401 (316)	For corrosion protection, acid resistant steels prove to be very good materials, e.g. 1.4301 (US Code 304). In a very aggressive environment, acid resistant steels are used as they contain more chemical elements such as nickel, chromium and molybdenum – 1.4401 (US Code 316). Systems made of acid resistant steels very often outclass alternative system made of plastics. Elements of acid resistant steel are mostly used in highly chemically aggressive environments (refineries, treatment plants, plastic processing plants). Poorly envisaged savings can in time lead to interrupted operation of the PV installation due to the need to replace the load-bearing structure of the installation. Application of individual grades: 1.4301 (304) – main applications include the food industry, gas tanks, equipment in nuclear power plants, system operated at low temperatures. 1.4016 (430) - mainly used like the grade described above (steel not suitable for welding) 1.4401 (316) – main applications include sewage treatment plants, sea environments, refining industry.																												
Aluminium alloys	[A] Stopy wg. PN-EN 573-3:2014-02	Aluminium in EN AW-6063 and EN AW-6005A grades is characterized by high strength and good corrosion resistance. It is suitable for anodising, which increases the corrosion resistance even more.																												
Steel + Stainless steel + Aluminium	[L] Powder coating	Polyester and epoxy powder coating (for internal coating). Coating thickness ranges from 80 µm to 120 µm; no primer or solvent is used. Powder coating on elements made of steel sheets, which are galvanized acc. to the Sendzimir method, provide smooth surfaces, which are free of cracks, runs and creases. Powder coating on elements made of hot-dip galvanized steel sheets does not provide perfectly smooth surfaces because hot-dip galvanized elements feature increased surface roughness, compared with the elements galvanized acc. to the Sendzimir method. Prior to painting, hot-dip galvanized elements undergo shotblasting to increase possibly adhesion of the paint to walls of the zinc-coated elements and remove zinc oxide, whose presence on the element prior to painting could result in coating spalling. Powder coating is characterised by high corrosion and chemical resistance, very good mechanical properties as well as water resistance. This solution is applied when improvement of corrosion resistance (by powder coating on galvanized sheets) is required. Coating durability depends on compliance with rules relating to transport, storage, installation method, chemical environment, where the structure is to be installed, and maintenance. The standard offer includes 14 colours (please see the pallet below). It is possible to order non-standard colour painting; however, this results in a higher price and longer time for completion of the purchase order. The paint is applied directly on the metal.																												
<table border="1"> <thead> <tr> <th>RAL 1015</th> <th>RAL1023</th> <th>RAL 2004</th> <th>RAL 5012</th> <th>RAL 5015</th> <th>RAL 7016</th> <th>RAL 7024</th> <th>RAL7032</th> <th>RAL7035</th> <th>RAL9002</th> <th>RAL9003</th> <th>RAL9005</th> <th>RAL9006</th> <th>RAL9010</th> </tr> </thead> <tbody> <tr> <td>light ivory</td> <td>traffic yellow</td> <td>pure orange</td> <td>light blue</td> <td>sky blue</td> <td>anthracite grey</td> <td>graphite grey</td> <td>pebble grey</td> <td>light grey</td> <td>grey white</td> <td>signal white</td> <td>jet black</td> <td>white aluminium</td> <td>pure white</td> </tr> </tbody> </table>			RAL 1015	RAL1023	RAL 2004	RAL 5012	RAL 5015	RAL 7016	RAL 7024	RAL7032	RAL7035	RAL9002	RAL9003	RAL9005	RAL9006	RAL9010	light ivory	traffic yellow	pure orange	light blue	sky blue	anthracite grey	graphite grey	pebble grey	light grey	grey white	signal white	jet black	white aluminium	pure white
RAL 1015	RAL1023	RAL 2004	RAL 5012	RAL 5015	RAL 7016	RAL 7024	RAL7032	RAL7035	RAL9002	RAL9003	RAL9005	RAL9006	RAL9010																	
light ivory	traffic yellow	pure orange	light blue	sky blue	anthracite grey	graphite grey	pebble grey	light grey	grey white	signal white	jet black	white aluminium	pure white																	



Electrical continuity

BAKS PV system meet the requirements of electrical continuity, which through proper installation and earthing ensure safety in the operation of the PV system including cabling.

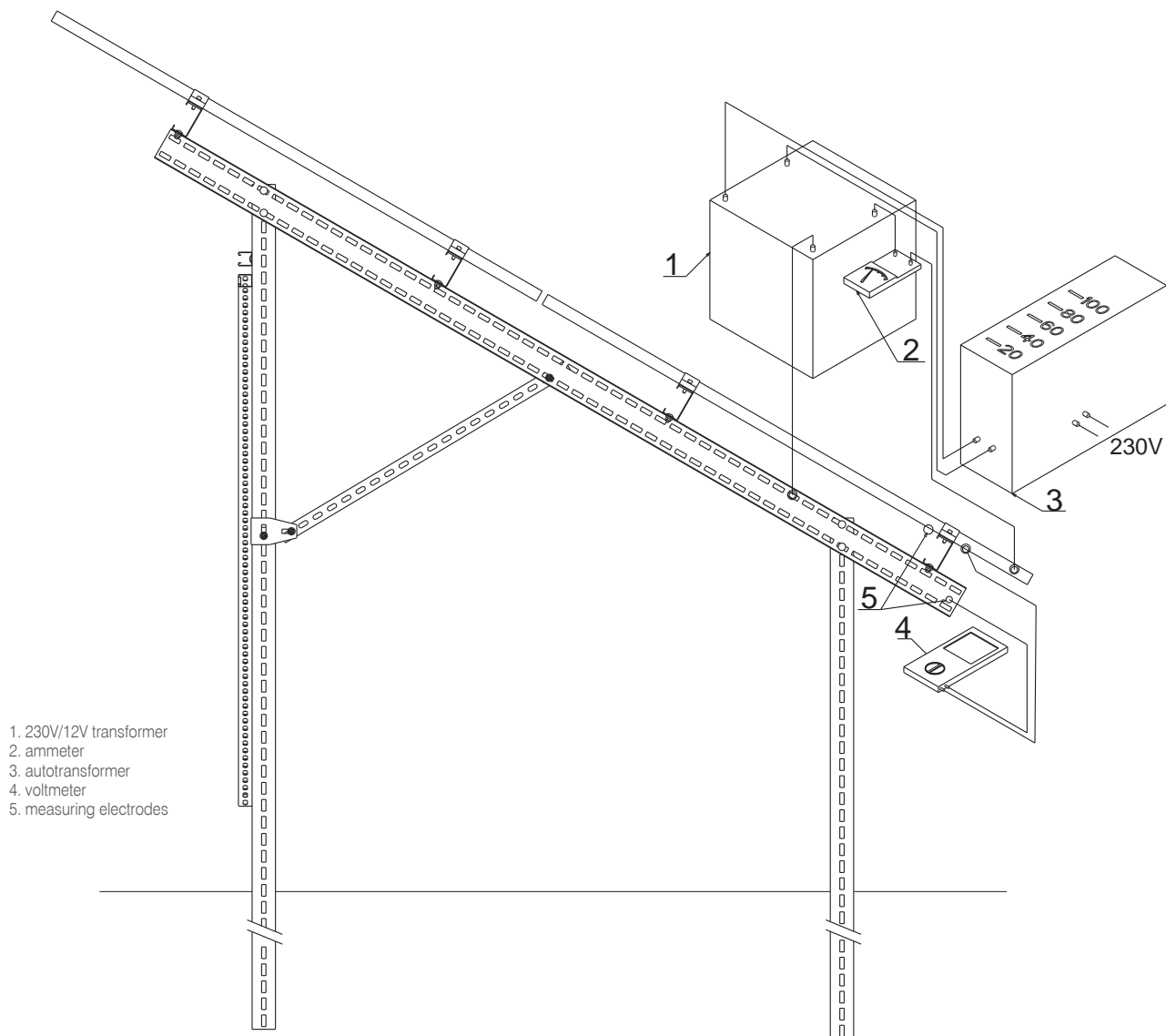

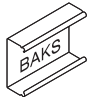

CERTIFICATE

no: TM 61000636.001



Licence holder

BAKS Kazimierz Sielski
st. Jagodne 5
05-480 Karczew, PL

Manufacturing plant

BAKS Kazimierz Sielski
st. Jagodne 5
05-480 Karczew, PL

Project number

26100721

Our reference

SD/84965069

Certificate validity period

from 16.02.2023 to 15.02.2028

Basis of research

PC-TUV-I21 Procedure for the certification of structures for the fitting of photovoltaic panel systems

PB-TUV-78: 2012 Solar panel mounting system. Safety requirements and test methods based on:

PN-EN 1990:2004

PN-EN 1991-1-1:2004

PN-EN 1991-1-3:2005

PN-EN 1991-1-4:2008

PN-EN 1993-1-1:2006

PN-EN 1993-1-3:2008

PN-EN 1999-1-1:2011

TÜV Rheinland Polska Sp. z o.o. declares that the product described below meets the requirements contained in the reference documents:

Mounting systems for photovoltaic panels:

- free-standing structures - W-H... ; W-V... ;
- structures for pitched roofs - DS-V... ; DS-H... ;
- structures for flat roofs - DP-DT... ; DP-DN... ;
- structures for facades and balustrades - E-V... ; E-H... ; B-V... ; B-H...

TÜV Rheinland Polska Sp. z o.o.

st. Wolności 347,
41-800 Zabrze, Polska
tel.: +48 32 271 64 89
e-mail: post@pl.tuv.com



Certification body

Tomasz Opaszowski

Zabrze, 16.02.2023

This certificate is subject to the Certification Terms and Conditions and the JCW TRP General Transaction Conditions and applies only to the products that are compliant with the standard used for compliance assessment. This certificate alone does not entitle the holder to affix the CE mark. This certificate entitles the holder to affix the product with the TUV mark.



Safety
Regular
Production
Surveillance



www.tuv.com
ID 0000055707

TÜVRheinland®
Precisely Right.

www.tuv.pl



T2.7-MS-0034790, Revision: 6

CERTIFICATE

conformity of the Factory Production Control

2627-CPR-1090-1.PL0269.TÜVRh.23.00

In compliance with Regulation 305/2011/EU of the European Parliament and of the Council of 9 March 2011 (the Construction Products Regulations - CPR)

This certificate applies to the following construction product:

Construction product	Structural components and kits for steel and aluminium structures to EXC2 according to EN 1090-2:2018, EN 1090-3:2008, EN 1090-4:2018, EN 1090-5:2017
Intended use	for load-bearing structures in all types of buildings and for thin-gauge, cold-formed steel elements and structures for roof, ceiling, floor and wall applications
CE-marking method	ZA.3.2, ZA.3.4 according to EN 1090-1:2009+A1:2011
Manufacturer	BAKS - Kazimierz Sielski ul. Jagodne 5 05-480 Karczew Polska
Manufacturing plant <small>Production facility of the manufacturer</small>	ul. Jagodne 5, 05-480 Karczew
Confirmation	This certificate attests that all provisions concerning the assessment and verification of constancy of performance described in Annex ZA of the harmonised standard EN 1090-1:2009+A1:2011 under system 2+ are applied and that the factory production control is assessed to be in conformity with the applicable requirements.
Date of first issue	05.08.2020
Validity	This certificate will remain valid as long as neither the harmonised standard, the construction product, the AVCP methods nor the manufacturing conditions in the plant are modified significantly, unless suspended or withdrawn by the notified factory production control certification body.
Next Surveillance inspection	04.08.2026
Place and date of issue	Zabrze, 01.09.2023

Leszek Zadroga

 Leszek Zadroga
 Notified Body

© TÜV, TÜEV and TÜV are registered trademarks. Utilisation and application requires prior approval

www.tuv.com





ZERTIFIKAT CERTIFICATE

Auftraggeber / Hersteller
Client / Manufacturer

BAKS – Kazimierz Sielski
ul. Jagodne 5
PL-05-480 Karczew

Erzeugnis
Product

Kabelträgersystem für elektrische Installation
Cable tray systems and cable ladder systems

Prüfbericht Nr. / Test Report Ref. No.

5018795-5430-0001/219753

Typenbezeichnung
Type designation

Siehe Prüfbericht / see Test Report

Technische Merkmale
Technical characteristics

Siehe Prüfbericht / see Test Report

Angewandte Normen
Applied standards

DIN EN 61537 (VDE 0639):2007-9;
EN 61537:2007

Geprüfte Abschnitte
Tested clauses

Abschnitt 11.1: Elektrische Leiteigenschaften
Sub clause 11.1: Electrical continuity

Ein Muster dieses Erzeugnisses wurde geprüft und die Übereinstimmung mit den angewandten Normen festgestellt. Der oben genannte Prüfbericht ist Grundlage dieses Zertifikates.

A sample of the product has been tested and found to be in conformity with the applied standards. The above mentioned Test Report is part of this certificate.

Dieses Zertifikat darf Dritten nur in Verbindung mit dem oben genannten Prüfbericht im vollen Wortlaut und unter Angabe des Ausstellungsdatums zur Kenntnis gegeben werden.

This certificate may only be passed to a third party in combination with the above mentioned Test Report in its complete wording and the date of issue.

VDE Prüf- und Zertifizierungsinstitut GmbH
VDE Testing and Certification Institute GmbH

Kategorie CC4
Category CC4

D-63069 Offenbach am Main, 13. April 2016
Merianstraße 28

Für den Binnenmarkt der Europäischen Union (EU) ist das VDE-Prüfinstitut unter der Kenn-Nr. 0366 notifiziert worden.

The VDE Testing and Certification Institute has been notified with the Identification Number 0366 for the Internal Market of the European Union (EU).

Tel. (+49) (069) 8306-237 · Fax (+49) (069) 8306-745 · e-mail: Reiner.Lehrer@vde.com



DAT-P-024/92-03



ZERTIFIKAT CERTIFICATE

Auftraggeber / Hersteller
Client / Manufacturer

BAKS – Kazimierz Sielski
ul. Jagodne 5
PL-05-480 Karczew

Erzeugnis
Product

Kabelträgersystem für elektrische Installation
Cable tray systems and cable ladder systems

Prüfbericht Nr. / Test Report Ref. No.

5018795-5430-0001/228892

Typenbezeichnung
Type designation

Siehe Prüfbericht / see Test Report

Technische Merkmale
Technical characteristics

Siehe Prüfbericht / see Test Report

Angewandte Normen
Applied standards

DIN EN 61537 (VDE 0639):2007-9;
EN 61537:2007

Geprüfte Abschnitte
Tested clauses

Abschnitt 11.1: Elektrische Leiteigenschaften
Sub clause 11.1: Electrical continuity

Ein Muster dieses Erzeugnisses wurde geprüft und die Übereinstimmung mit den angewandten Normen festgestellt. Der oben genannte Prüfbericht ist Grundlage dieses Zertifikates.

A sample of the product has been tested and found to be in conformity with the applied standards. The above mentioned Test Report is part of this certificate.

Dieses Zertifikat darf Dritten nur in Verbindung mit dem oben genannten Prüfbericht im vollen Wortlaut und unter Angabe des Ausstellungsdatums zur Kenntnis gegeben werden.

This certificate may only be passed to a third party in combination with the above mentioned Test Report in its complete wording and the date of issue.

VDE Prüf- und Zertifizierungsinstitut GmbH
VDE Testing and Certification Institute GmbH

Kategorie CC4

Category CC4

A. Herzog

D-63069 Offenbach am Main, **23. August 2016**

Merianstraße 28

Tel. (+49) (069) 8306-237 · Fax (+49) (069) 8306-745 · e-mail: Reiner.Lehrer@vde.com

Für den Binnenmarkt der Europäischen Union (EU) ist das VDE-Prüfinstitut unter der Kenn-Nr. 0366 notifiziert worden.

The VDE Testing and Certification Institute has been notified with the Identification Number 0366 for the Internal Market of the European Union (EU).



DAT-P-024/92-03



Certificate

Standard ISO 9001:2015

Certificate Registr. No. 01 100 1331984

Certificate Holder: BAKS Wytwarzanie **Osprzętu**
Instalacyjno-Elektrotech.
Kazimierz Sielski; BAKS
Kazimierz Sielski
ul. Jagodne 5
05-480 Karczew
Poland

Scope: - Design and manufacturing of metal support systems for cables,
wires and ventilation channels
- Powder coating
- HOT-DIP galvanising

Proof has been furnished by means of an audit that the requirements of ISO 9001:2015 are met.

Validity: The certificate is valid from 2026-04-19 until 2029-04-18.
First certification 2001

2026-02-23

TÜV Rheinland Cert GmbH
Am Grauen Stein · 51105 Köln

© TÜV, TÜEV and TUV are registered trademarks. Utilisation and application requires prior approval.

www.tuv.com





Certificate

Standard ISO 14001:2015

Certificate Registr. No. 01 104 1541861

Certificate Holder: BAKS Wytwarzanie **Osprzętu**
Instalacyjno-Elektrotech.
Kazimierz Sielski; BAKS
Kazimierz Sielski
ul. Jagodne 5
05-480 Karczew
Poland

Scope: - Design and manufacturing of metal support systems for cables,
wires and ventilation channels
- Powder coating
- HOT-DIP galvanising

Proof has been furnished by means of an audit that the requirements of ISO 14001:2015 are met.

Validity: The certificate is valid from 2026-02-27 until 2029-02-26.
First certification 2017

2026-02-23

TÜV Rheinland Cert GmbH
Am Grauen Stein · 51105 Köln

© TÜV, TÜEV and TUV are registered trademarks. Utilisation and application requires prior approval.

www.tuv.com



The BAKS company is aware of its impact on the natural environment and therefore in all its activities is guided by care for natural resources and responsibility for the state of the environment. We operate in accordance with the requirements of ISO 14001:2015, as confirmed by the certificate below.



NATIONAL DECLARATION OF PERFORMANCE



NR 1/2026

1. Product name:
Mounting systems for photovoltaic panels, including freestanding structures, structures for flat roofs, structures for pitched roofs, facade structures, and balustrade structures, the specifications of which can be found in the BAKS catalog.
Flat roofs: DP-DNH..., DP-DTH..., DP-DTAV..., DP-DTV...
Pitched roofs: DS-H1..., DS-H2..., DS-H3..., DS-H4..., DS-H5..., DS-H6..., DS-H7..., DS-V1..., DS-V2..., DS-V3..., DS-V4..., DS-V5..., DS-V6..., DS-V7...
Freestanding structures: W-H4...2, W-H4...2-BI, W-H5...2, W-H6...2, W-V2...2, W-V2...2-BI, W-V3...2, W-V2...1, W-V2...3-WZ, W-H3...3-WZ, W-H4...3-WZ
Facade and balustrade structures: E-H..., E-V..., B-H..., B-V...
2. Scope of application:
The structures are used as supporting structures for photovoltaic modules mounted on pitched roofs, flat roofs, facades and balustrades and on the ground.
3. Producer:
„BAKS” Kazimierz Sielski, Jagodne 5 str, 05-480 Karczew. Poland
4. Authorized Representative: Not applicable.
5. System for assessing and verifying constancy of performance: SYSTEM 2+
Certyfikat TÜV ZKP/FPC 2627-CPR_1090-1.PL0269.TÜVRh.23.00
Certyfikat TÜV 8610-1090-2.PL0195.TÜVRh.23.00
Certyfikat TÜV SZJ ISO 9001:2015 nr 011001331984
Certyfikat TÜV wyrobu nr TM 61000636.001
6. Harmonized standard: PN-EN 1090-1:2012
7. Declared performance properties:

Essential characteristics of the product	Declared performance properties:	Harmonized Technical Specification
Construction class	EX2	PN-EN 1090-2:2018 PN-EN 1090-3:2019
Dimensional tolerance	Class 1	PN-EN 1090-2:2018 PN-EN 1090-3:2019
Weldability	1.1, 1.2, 8, 22 wg CEN ISO/TR 15608	PN-EN 1090-2:2018
Resistance to cracking	NPD	PN-EN 1090-2:2018 PN-EN 1090-3:2019
Fatigue strength	NPD	PN-EN 1090-2:2018 PN-EN 1090-3:2019
Load capacity and deformation	Wg projektu i obliczeń dla typu konstrukcji zgodnie z PN-EN 1990:2004; PN-EN 1991-1-1:2004; PN-EN 1991-1-3:2005; PN-EN 1991-1-4:2008, PN-EN 1993-1-1:2006, PN-EN 1993-1-3:2008, PN-EN 1999-1-1:2011	PN-EN 1090-2:2018 PN-EN 1090-3:2019
Reaction to fire	NPD	PN-EN 1090-2:2018 PN-EN 1090-3:2019
Fire resistance	NPD	PN-EN 1090-2:2018 PN-EN 1090-3:2019
Cadmium content	NPD	PN-EN 1090-2:2018 PN-EN 1090-3:2019
Content of radioactive substances	NPD	PN-EN 1090-2:2018 PN-EN 1090-3:2019
Durability	NPD	PN-EN 1090-2:2018 PN-EN 1090-3:2019

8. The performance of the product specified above is consistent with the set of declared performance characteristics. This national declaration of performance is issued in accordance with Regulation (EU) No. 305/2011 under the sole responsibility of the manufacturer.

Karczew 02.01.2026

Kazimierz Sielski



Signature

Examples of how to install PV panels

Installing clamps on the long sides

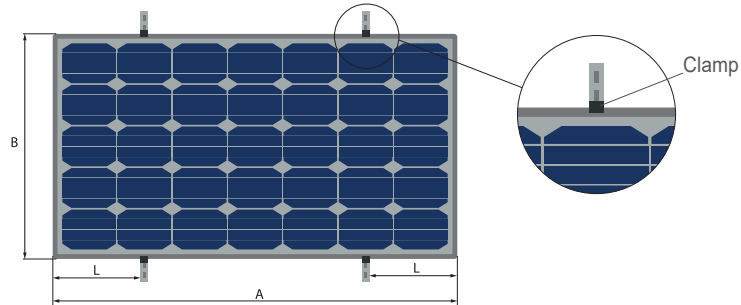

Mounting the clamps on the short sides

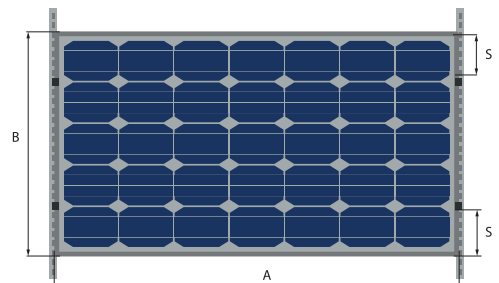
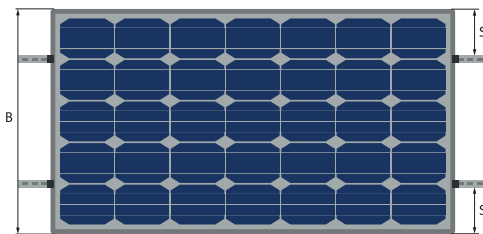

Installing clamps on the corners

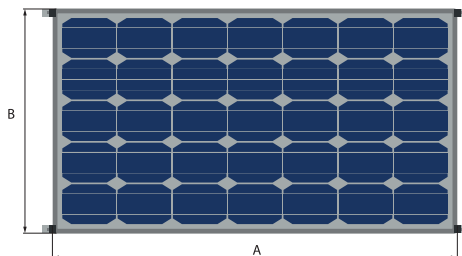

Mixed clamp installation
(on the short and long sides)

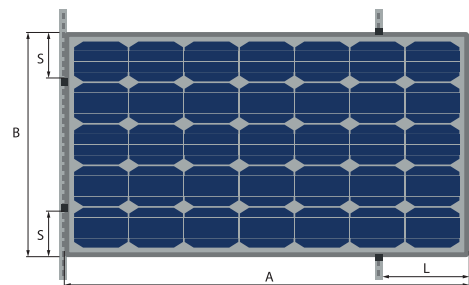

- A - panel length
- B - panel width
- L - distance from the shorter edge of the panel where the clamps should be applied
- S - distance from the longer edge of the panel where the clamps should be applied

Permissible mounting locations for panels to the structure (so-called mounting zones) should be checked in the PV panel installation instructions.

Please note:

- panel orientation (vertical or horizontal mounting)
- panel mounting method (mounting clamps or screws screwed directly to the panel frame)
- permissible mounting locations (mounting zones), including the possibility of mounting on the short side
- panel load capacity for a given mounting solution (to ensure panel mounting is possible in selected wind and snow zones).

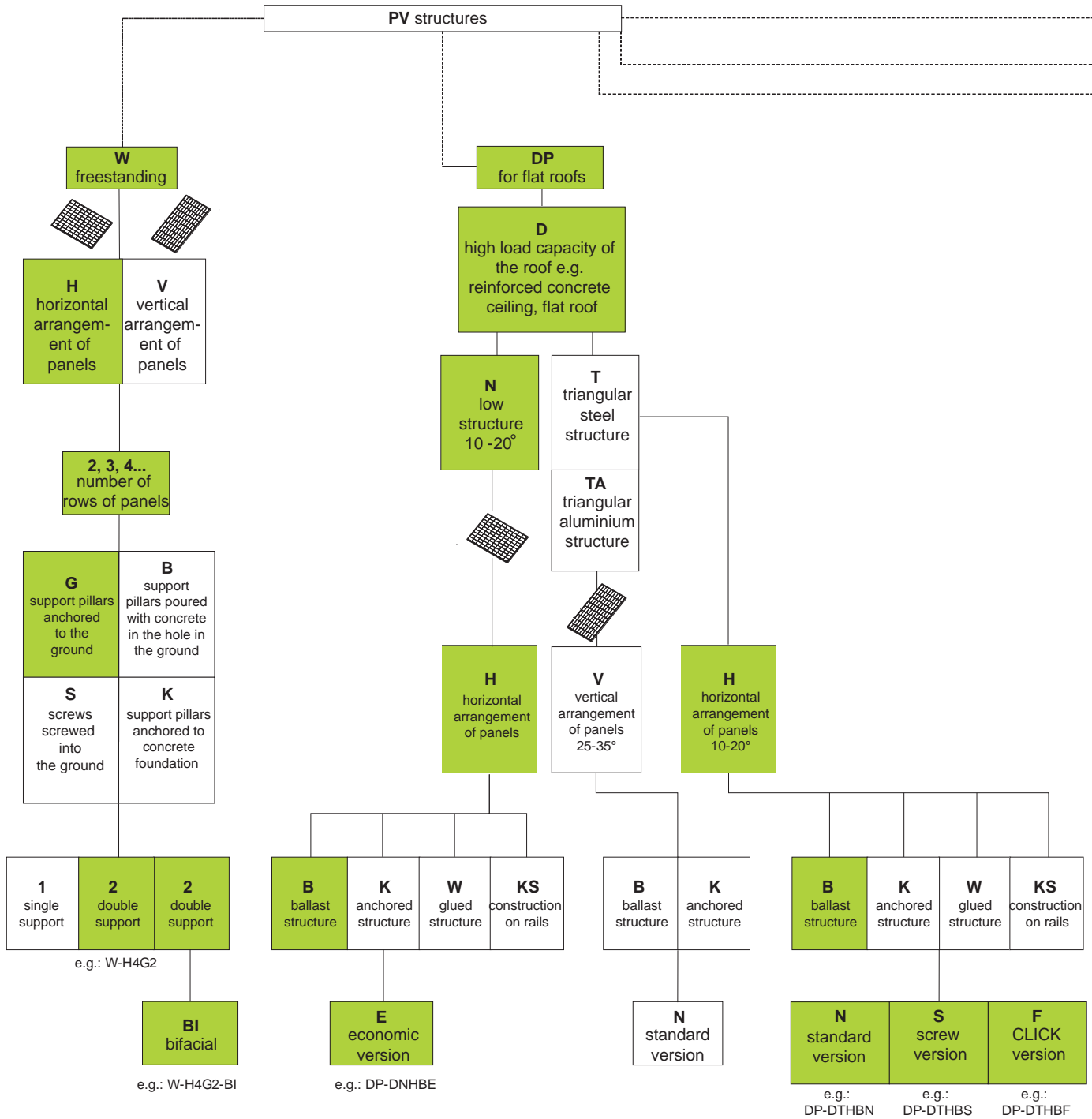

An example selection path of a structure is marked with green

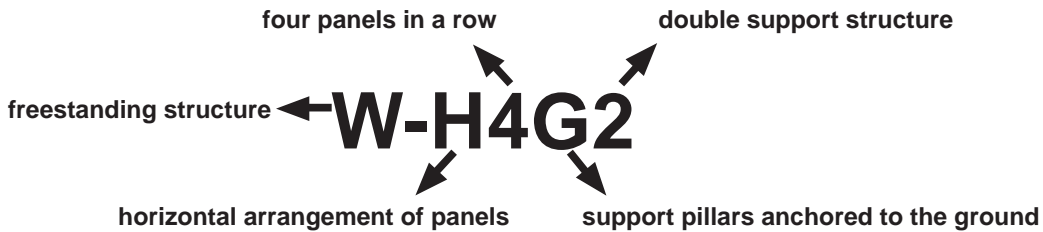

DS
for sloping roofs

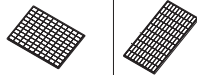

H horizontal arrangement of panels	V vertical arrangement of panels
--	--

type of roof plating:

- 1 - metal tile sheets
 - double threaded screw
 - a - metal tile sheets
 - aluminium rail
- 2 - sheet metal seam plate
- 3 - bituminous tile
 - a - bituminous tile
 - adjustable fixture

4 - ceramic tile

- 5 - scale-shaped tile
- 6 - trapezoidal metal sheet:
 - a - high rail
 - b - low rail
 - c - adjustable fixture

N standard version	E economic version
---------------------------------	---------------------------------

e.g.: DS-H4N

E
or building elevations

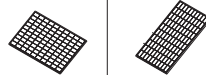

H horizontal arrangement of panels	V vertical arrangement of panels
--	--

K
anchored
structure

R parallel version	T triangular version
---------------------------------	-----------------------------------

N
standard
version

e.g.: E-HKRN

B
for balcony railings

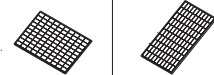

H horizontal arrangement of panels	V vertical arrangement of panels
--	--

P
screwed-in
structure

N
standard
version

e.g.: B-VPN

FREE PV BAKS APP

Our photovoltaic design application was created to simplify the design process as much as possible. Thanks to its intuitive interface, users can prepare a complete structure configuration in just minutes—for both rooftop and ground-mounted installations. The system automatically selects compatible components, takes into account technical parameters and eliminates the risk of errors that often occur during manual design.

The application integrates engineering knowledge, manufacturer experience, and installation practice, offering a complete set of tools needed for the quick and precise creation of PV designs. The generated technical documentation is ready for use during the installation phase, audits, and design approvals. This solution significantly reduces work time, increases efficiency, and allows you to focus on key aspects of the investment.

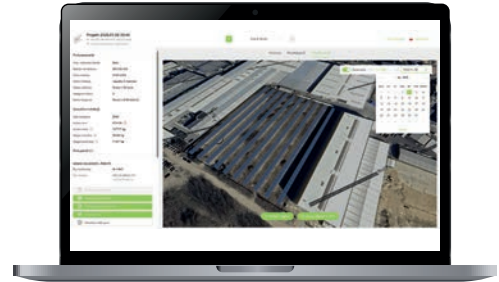

The application is available at www.baks.com.pl in the PV Structures tab -> PV Application, pv.baks.com.pl

THANKS TO OUR APPLICATION



YOU WILL DESIGN STRUCTURES FOR FLAT ROOFS



YOU WILL DESIGN STRUCTURES FOR A PITCHED ROOF



YOU WILL DESIGN DETACHED STRUCTURES



YOU WILL DESIGN A CARPORT



YOU WILL GENERATE A LIST OF ELEMENTS WITH PRICE

Project data

Project Name *
Project 2025.12.12 11:17

Customer's name * Contact phone number

Planned installation date * Power of the installation
2026-01-02 0 kW

Installation address *
Enter photovoltaic installation... Show on map

Wind zone * Snow zone *

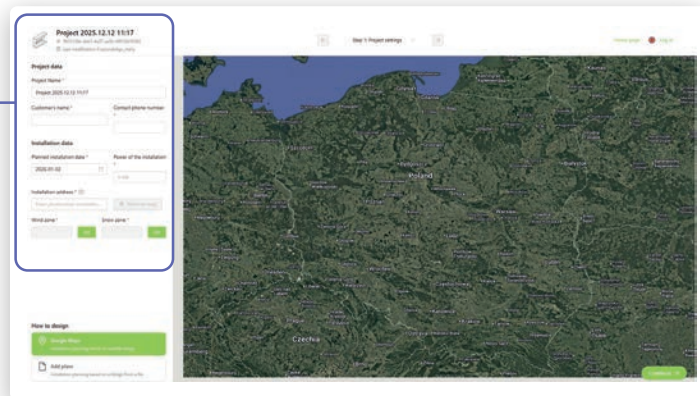

Site configuration

Place type
Carport

Name
Area #1

Surface
15154.50 m²

System parameters

Protection zone
50 cm

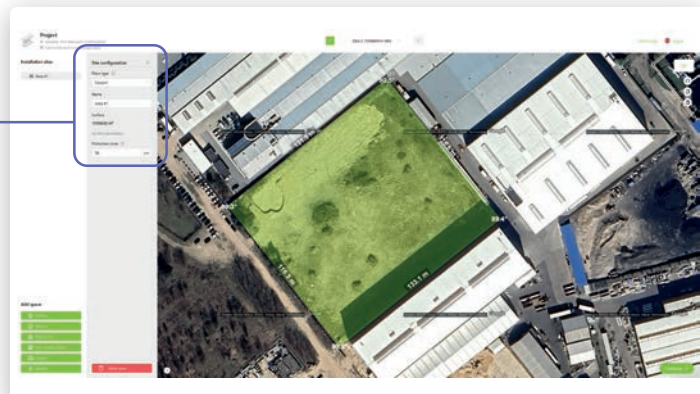



Download the XLS summary

Download the summary in PDF

Download DXF file

WELCOME TO OUR TUTORIAL

Explore our photovoltaic design application and see how you can create complete PV designs in a simple and intuitive way. In this course, we'll guide you step-by-step through all the tool's features – from module selection, through structure configuration, to generating finished documentation.

Our guide was created with designers, installers, and all specialists in mind who want to speed up their work, avoid errors, and create professional designs faster.

- How to design a building?
- How to design a carport?
- How to design a structure for a pitched roof?
- How to design a freestanding structure?
- How to design a structure for a flat roof?
- How to generate a bill of materials and a quote?
- How to generate a DXF file?
- How to verify shading?



https://www.youtube.com/@baks_international

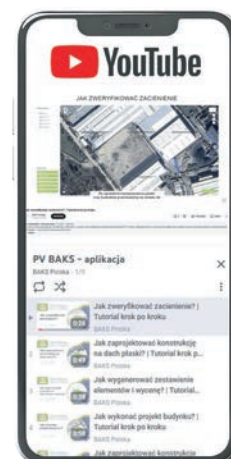



List of important information for selecting a PV installation on an inclined roof

1. What the roof is covered with?

Roofing sheet	Seam sheet	Bitumen shingles	Ceramic/concrete tile	Plain tile	Trapezoidal sheet
---------------	------------	------------------	-----------------------	------------	-------------------

2. Rafter spacing

3. Panel orientation

Horizontal	Vertical
------------	----------

4. Panel dimensions

5. Location of the project

6. Panel layout (Number of rows and number of panels per row)

7. Additional comments and observations on the use of PV components/structures (non-standard components/solutions, painted components, additional requirements)

8. I agree that the cheapest version of the PV design that meets current standards will be selected.

List of important information for selecting a PV installation on a flat roof

1. Type of construction (preferably catalogue symbol)

2. Beam spacing

3. Method of installation

Ballast	Anchored	Pasted	On the SM... rails
---------	----------	--------	--------------------

4. Panel dimensions

5. Roof coverage

6. Roof pitch angle

7. Angle of inclination of panels

8. Location of the project

9. Panel layout (Number of rows and number of panels per row)

10. Additional comments and observations on the use of PV components/structures (non-standard components/solutions, painted components, additional requirements)

11. I agree that the cheapest version of the PV design that meets current standards will be selected.



List of important information for the selection of a free-standing PV installation

1. Type of construction (preferably catalogue symbol)

2. Method of installation

Driven	Concreted	Anchored to foundation	Screwed in
<input type="checkbox"/>	<input type="checkbox"/>	<input type="checkbox"/>	<input type="checkbox"/>

3. Anchorage depth

4. Panel dimensions

5. Angle of inclination of the panels

6. Table dimensions

7. Number of tables

8. Location of the project

9. Additional comments and observations on the use of PV components/structures (non-standard components/solutions, painted components, additional requirements)

10. I agree that the cheapest version of the PV design that meets current standards will be selected.

The survey aims to improve and speed up the bidding process and to include important technical details.

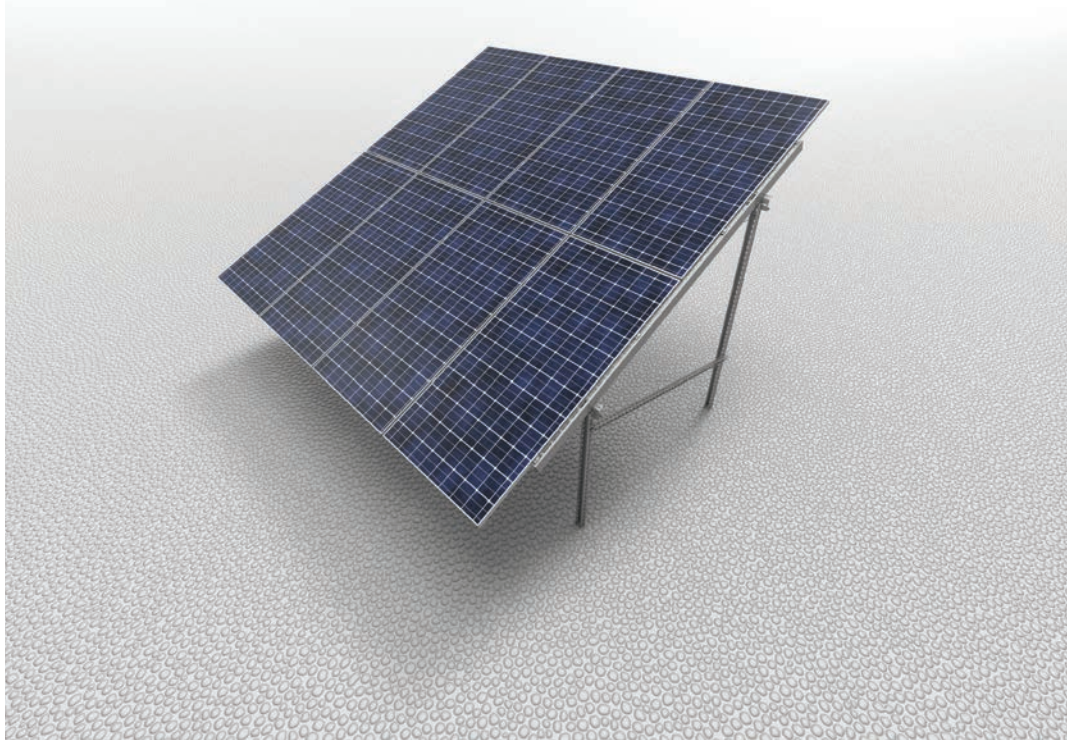

Freestanding mounting structures for the installation of photovoltaic panels



Freestanding structures systems:

- System: **W-V2G1** (2 panels arranged vertically on 1 support post)
- System: **W-V2G2** (2 panels arranged vertically on 2 support posts)
- System: **W-V2G2-BI** (2 panels arranged vertically on 2 support posts with bifacial panels)
- System: **W-V2G3-WZ** (2 panels arranged vertically on 3 support columns) (east-west)
- System: **W-V3G2** (3 panels arranged vertically on 2 support posts)
- System: **W-H3G3-WZ** (3 panels arranged horizontally on 3 support columns) (east-west)
- System: **W-H4G2** (4 panels arranged horizontally on 2 support posts)
- System: **W-H4G2-BI** (4 panels arranged horizontally on 2 support posts with bifacial panels)
- System: **W-H5G2** (5 panels arranged horizontally on 2 support posts)
- System: **W-H6G2** (6 panels arranged horizontally on 2 support posts)
- System Carport: **K1, DK1, K10, DK10, K2, DK2, K20, DK20, KP1, KP2, KVI, KVIO, KV, KVO**

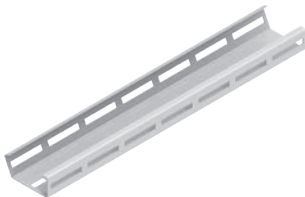
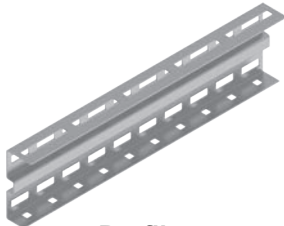
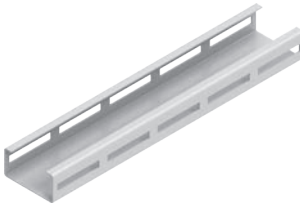
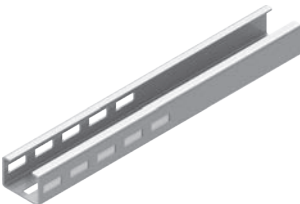
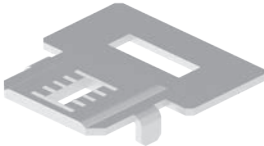
Examples of system components:

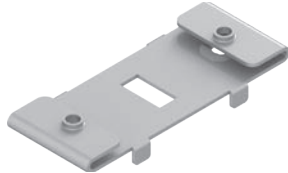
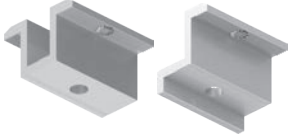





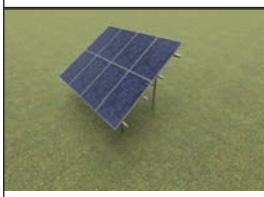

 <p>Support Channel CWCR100H50...MC</p>	 <p>Profile BDFCH120...NMC</p>	 <p>Support Channel CWC100H50...NMC</p>	 <p>Support Channel CWBT70H50...MC</p>
 <p>End panel bolt adapter ASPKMC</p>	 <p>Middle panel bolt adapter ASPPMC</p>	 <p>Middle panel bolt adapter ASPGMC</p>	 <p>Intermediate and side panel mount with grounding pad PUFP i BUFP...</p>

Advantages of freestanding mounting structures for the installation of photovoltaic panels

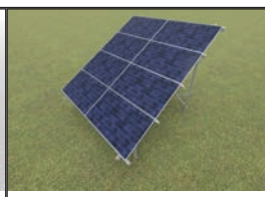
- dense profile perforation provides a wide adjustment range without drilling
- longitudinal profile perforation allows for smooth adjustment of the inclination angle of the structure in relation to the ground
- possibility of assembling the structure - with only one type of screws - SGKFM10x20
- the perforation of the profiles reduces the weight of the structure - without reducing their strength properties. This means that installers do not have to carry heavy profiles and their work is more efficient.
- dense perforation allows panels to be mounted anywhere without drilling
- by using u-profiles, there is a possibility of laying cables in it safely
- thanks to the use of the SPV wire clip, the cables laid in the CWC100H50..NMC support channel are protected against falling out and using unaesthetic and nondurable cable ties can be avoided
- the top perforation of the CWC100H50...NMC support channel allows for quick installation of clamps when using NRM8PV channel nuts
- longitudinal perforation of support profiles allows for quick installation of brackets and cable trays for safe cable routing and installation of structures for inverters
- production of profiles is carried out on top-class perforating machines, which ensures high quality and repeatability of the products. Profile ends are virtually free of sharp edges, which significantly reduces the possibility of installer's injuries
- profiles made of sheet metal with Magnelis®, MagiZinc®, PosMAC coating for long-term corrosion resistance
- the use of mounting templates allows for quick determination of location of holes for screwing on subsequent elements of the structure and mounting clamps
- possibility of producing vertical support columns without perforation, partially driven into the ground
- PUFEP, PUFEP, BUFP..., BUFP... clamps with grounding washers, without damaging the panel frames
- products made in Poland!

In the case of photovoltaic farm installations, it is possible to perform dedicated perforation in selected system elements.

Systems:

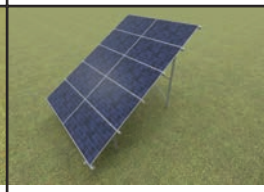
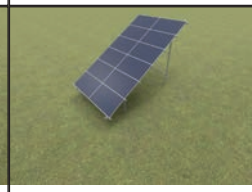
				
W-V2...2	W-V2...2-BI	W-H4...2	W-H4...2-BI	W-V2...1
				
W-V2...3-WZ	W-V3...2	W-H3...3-WZ	W-H5...2	W-H6...2

PV structures

FREE-STANDING CONSTRUCTION
System: **W-V2G2-30°-N**

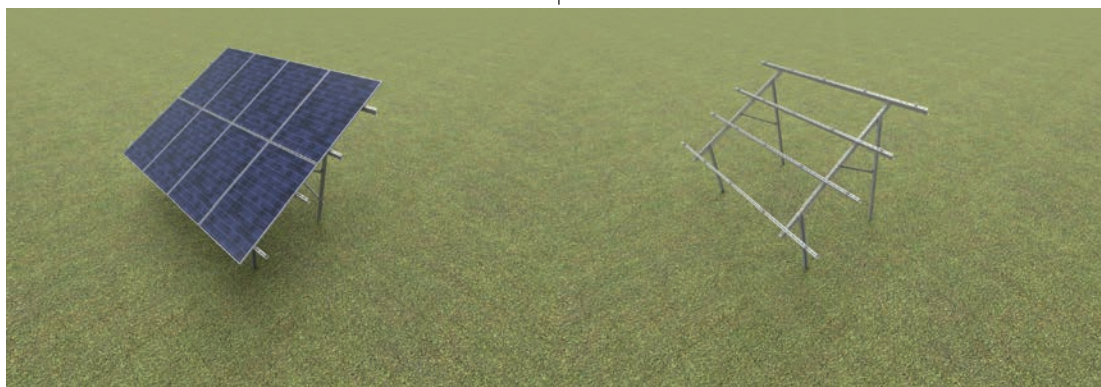

INSTALLATION INPUT DATA:

Panel dimensions:

Tilt angle:

Installation location:

Panel layout:

Method of mounting the structure to the ground:

EXAMPLES

Panel dimensions:
2094 x 1038 x 35 mm

30°

ŁÓDŹ (close to)

VERTICAL

G: Construction driven-in the ground

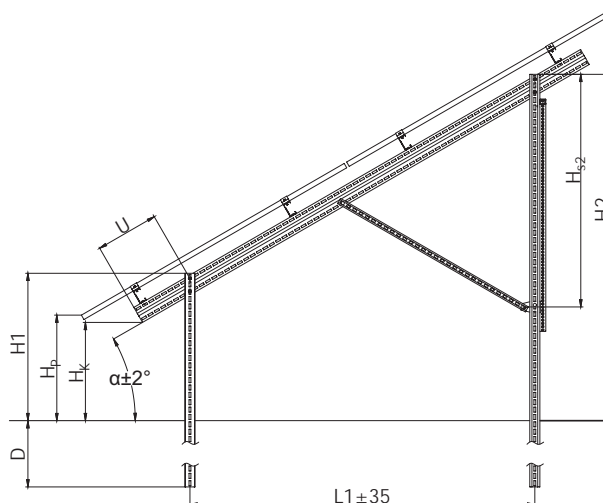

Determining the dimensions of free-standing structures for the installation of photovoltaic panels



Table 1 Lengths of construction elements depending on panel size

Construction angle „a”	Front support pillar	Rear support pillar	Rafter	Bracing No. 1
PANEL LENGTHS FROM 1600 TO 1700 mm CONSTRUCTION VARIANT A				
25°	CT70H50/3NMC lub CBT/CWBT70H50/...MC	CT70H50/4NMC lub CBT/CWBT70H50/...MC	BDFCH100/2,75NMC	CMP41H41/1MC
30°	CT70H50/3NMC lub CBT/CWBT70H50/...MC	CT70H50/4NMC lub CBT/CWBT70H50/...MC	BDFCH100/2,75NMC	CMP41H41/1MC
PANEL LENGTHS FROM 1700 TO 1800 mm CONSTRUCTION VARIANT A				
25°	CT70H50/3NMC lub CBT/CWBT70H50/...MC	CT70H50/4NMC lub CBT/CWBT70H50/...MC	BDFCH100/3,2NMC	CMP41H41/1MC
30°	CT70H50/3NMC lub CBT/CWBT70H50/...MC	CT70H50/4NMC lub CBT/CWBT70H50/...MC	BDFCH100/3,2NMC	CMP41H41/1MC
PANEL LENGTHS FROM 1800 TO 2100 mm CONSTRUCTION VARIANT A				
25°	CT70H50/3NMC lub CBT/CWBT70H50/...MC	CWT70H50/4,4NMC lub CBT/CWBT70H50/...MC	BDFCH120/3,6NMC	CMP41H41/1,5MC
30°	CT70H50/3NMC lub CBT/CWBT70H50/...MC	CWT70H50/4,4NMC lub CBT/CWBT70H50/...MC	BDFCH120/3,6NMC	CMP41H41/1,5MC
PANEL LENGTHS FROM 2100 TO 2300 mm CONSTRUCTION VARIANT B				
25°	CT70H50/3NMC lub CBT/CWBT70H50/...MC	CWT70H50/4,4NMC lub CBT/CWBT70H50/...MC	BDFCH120/4,4NMC	CMP41H41/1,2MC + CMP41H41/1,5MC
30°	CT70H50/3NMC lub CBT/CWBT70H50/...MC	CWT70H50/4,4NMC lub CBT/CWBT70H50/...MC	BDFCH120/4,4NMC	CMP41H41/1,2MC + CMP41H41/1,5MC

Table 2 Dimensions of the structure depending on the angle of inclination of the structure and the size of the panels

Construction angle „a”	Distance „L1”	Height						Distance „U”
		„H1”	„H2”	„HK”	„HP”	„Hs1”	„Hs2”	
PANEL LENGTHS FROM 1600 TO 1700 mm CONSTRUCTION VARIANT A								
25°	2080	1020	1990	800	870		1030	300
30°	1680	1020	1990	700	730		1040	480
PANEL LENGTHS FROM 1700 TO 1800 mm CONSTRUCTION VARIANT A								
25°	2080	1020	1990	720	790		1030	500
30°	1680	1020	1990	650	730		1040	580
PANEL LENGTHS FROM 1800 TO 2100 mm CONSTRUCTION VARIANT A								
25°	2400	970	2100	660	730		1530	430
30°	2400	1020	2400	680	730		1600	440
PANEL LENGTHS FROM 2100 TO 2300 mm CONSTRUCTION VARIANT B								
25°	2630	1020	2240	650	720	650	1530	580
30°	2770	1020	2610	680	730	670	1600	440

Tabela 3 Installation distance of successive construction frames

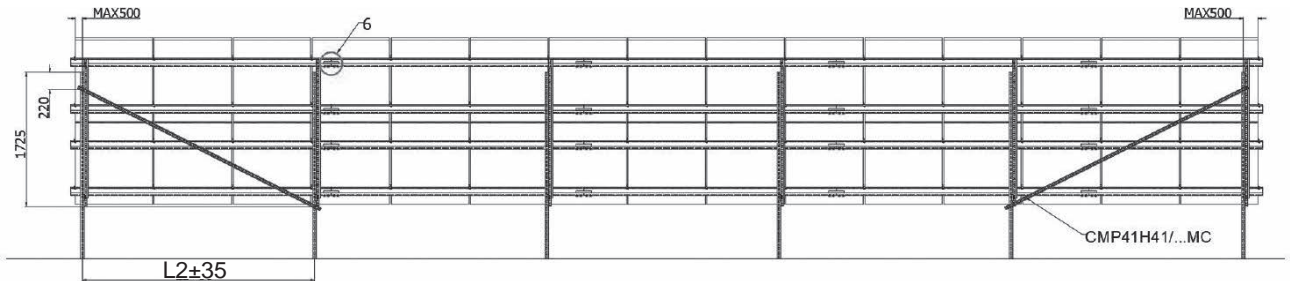

Combination of wind zone „W” and snow zone „S”	Maximum distance of subsequent frames „L2”
1W-1S lub 3W-1S	2,9 m
1W - 2S	
1W-3S lub 3W-3S	2,7 m
1W - 4S	
2W-2S lub 2W-3S	2 m
Other zone combinations	Individual selection

Fig.1 Structure assembly variants:

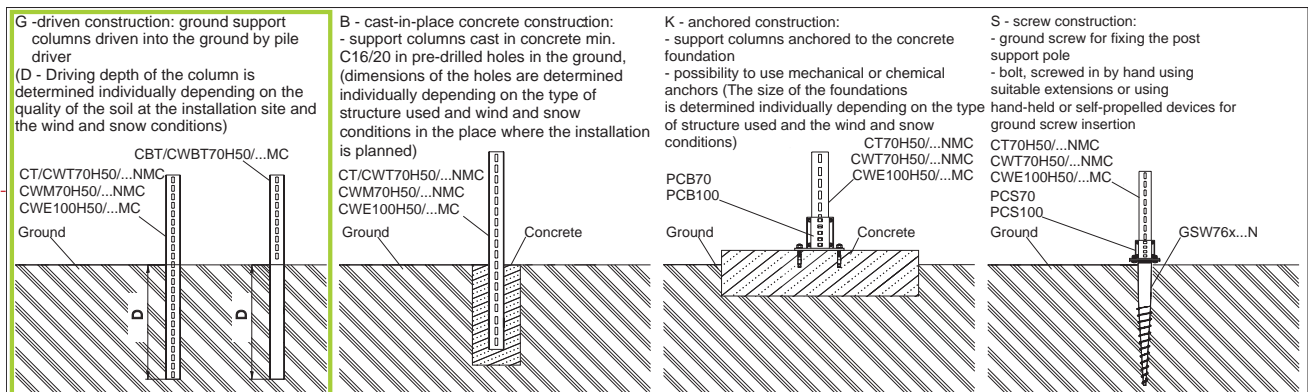

Recommended ways of mounting freestanding structures to the ground

Structure mounting variants:

G - driven construction:

- ground support columns driven into the ground by pile driver
- (D - Driving depth of the column is determined individually depending on the quality of the soil at the installation site and the wind and snow conditions)

B - cast-in-place concrete construction:

- support columns cast in concrete min. C16/20 in pre-drilled holes in the ground, (dimensions of the holes are determined individually depending on the type of structure used and wind and snow conditions in the place where the installation is planned)

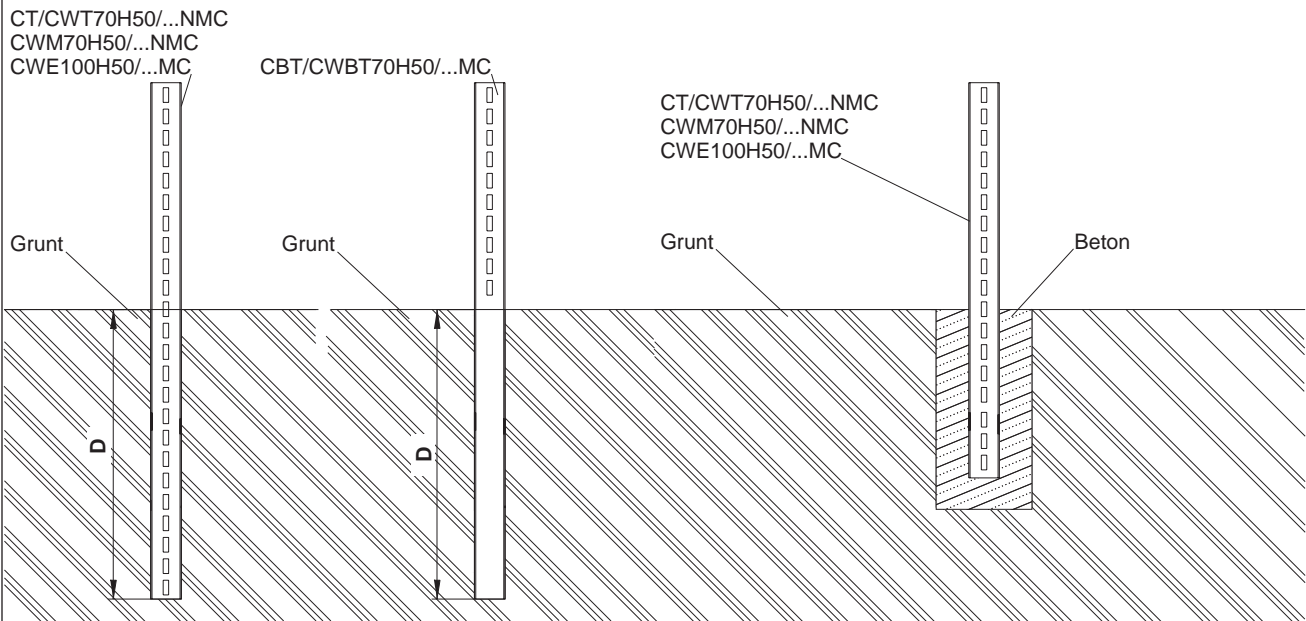

K - anchored construction:

- support columns anchored to the concrete foundation
- possibility to use mechanical or chemical anchors

S - screw construction:

- ground screw for fixing the post support pole
- bolt, screwed in by hand using suitable extensions or using hand-held or self-propelled devices for ground screw insertion

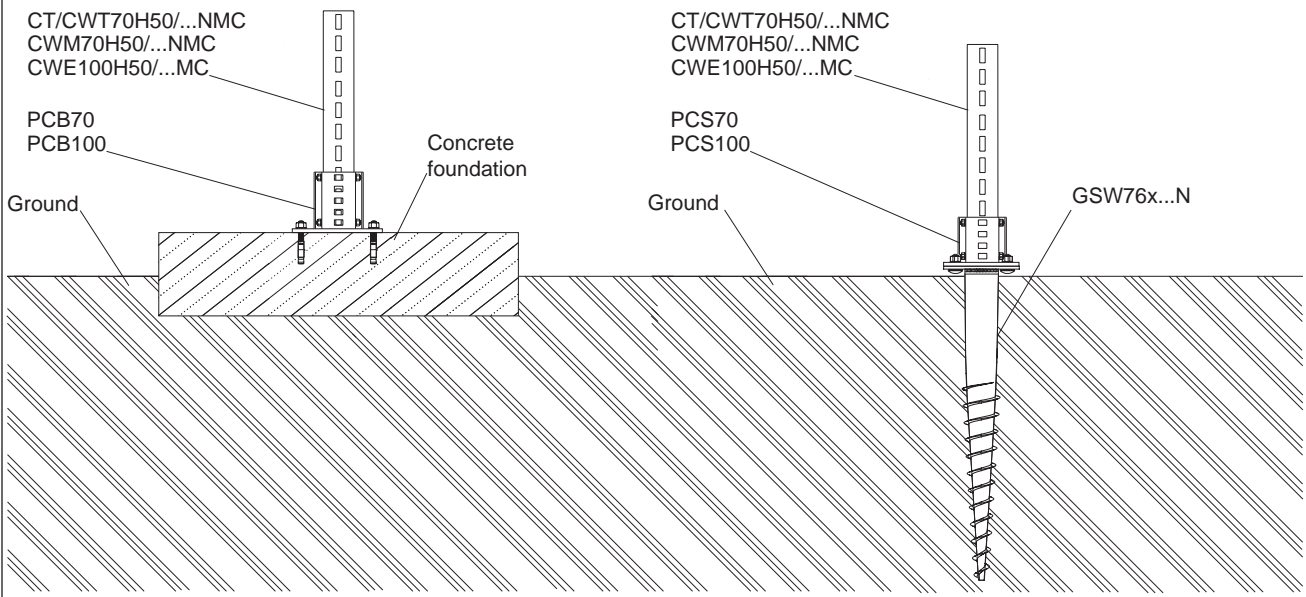

NEW! FREE-STANDING DESIGN WITH DEDICATED PERFORATION!

For stand-alone installations (with a capacity above 0.5 MWp), we also produce structures with dedicated perforation.

**NEW
DESIGN WITH DEDICATED PERFORATION!**

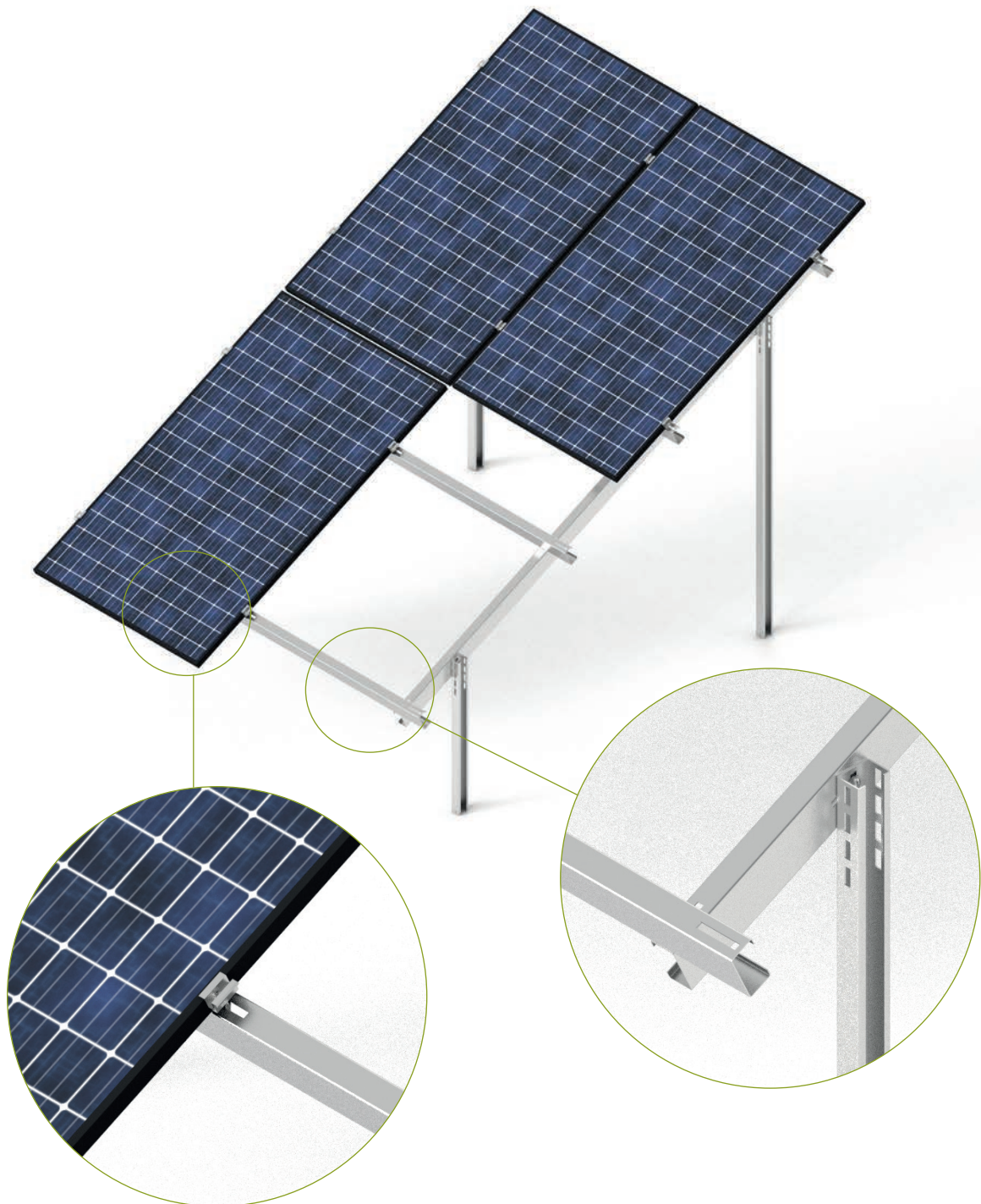



Freestanding mounting structure
System: W-V2G2-25° (optional 30°)

ST



Structure description:

Complete support system for fixing two rows of panels in a vertical arrangement.

Technical description:

Materials of the support system:
MC- Coated structural steel:
 Magnelis®, MagiZinc®, PosMAC
A- Aluminium
E- Stainless steel
F- Steel in zinc flake coating
 Structure tested for strength.

Arrangement of the modules:

· vertical - V

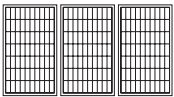

Structure assembly variants:

- **W-V2G2** design - driven into the ground (anchoring depth depends on ground conditions)
- **W-V2K2** structure - support columns anchored to the concrete foundation
- **W-V2B2** structure - support columns poured with concrete, min. C16/20, in holes drilled in the ground (hole size depends on ground conditions)
- **W-V2S2** design - on request, a screw screwed into the ground for attaching the support pole
- **W-V2...2-WZ** construction - east-west option

Warranty:

BAKS provides a 10 year Warranty: period for the components included in the support structure - only if all conditions of the manufacturer's Warranty: are met. The Warranty: can be extended.

Ground conditions:

· soil with good/high load capacity

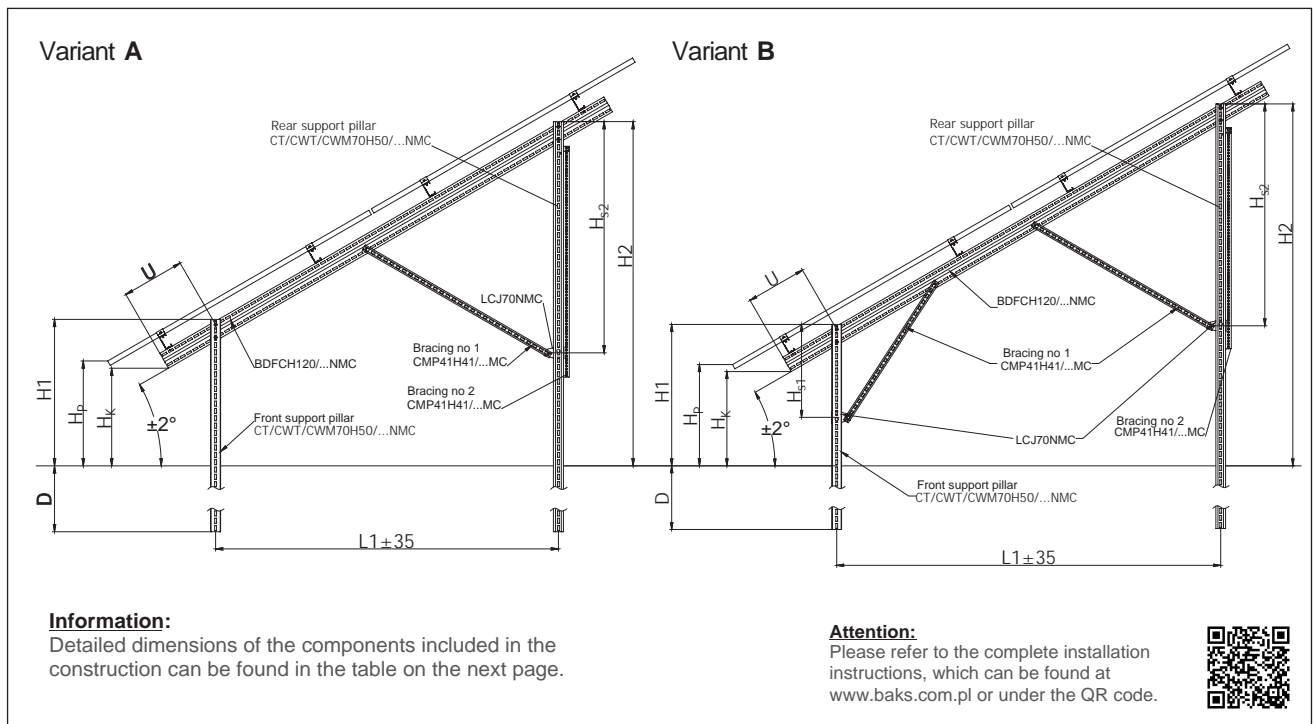

Information:
 Detailed dimensions of the components included in the construction can be found in the table on the next page.

Attention:
 Please refer to the complete installation instructions, which can be found at www.baks.com.pl or under the QR code.





DIMENSIONS OF CONSTRUCTION - FREE-STANDING CONSTRUCTION

System: W-V2G2-25°

Lengths of construction elements depending on panel size

Construction angle „a”	Front support pillar	Rear support pillar	Rafter	Bracing No. 1
PANEL LENGTHS FROM 1600 TO 1700 mm CONSTRUCTION VARIANT A				
25°	CT70H50/3NMC lub CBT/CWBT70H50/...MC	CT70H50/4NMC lub CBT/CWBT70H50/...MC	BDFCH100/2,75NMC	CMP41H41/1MC
30°	CT70H50/3NMC lub CBT/CWBT70H50/...MC	CT70H50/4NMC lub CBT/CWBT70H50/...MC	BDFCH100/2,75NMC	CMP41H41/1MC
PANEL LENGTHS FROM 1700 TO 1800 mm CONSTRUCTION VARIANT A				
25°	CT70H50/3NMC lub CBT/CWBT70H50/...MC	CT70H50/4NMC lub CBT/CWBT70H50/...MC	BDFCH100/3,2NMC	CMP41H41/1MC
30°	CT70H50/3NMC lub CBT/CWBT70H50/...MC	CT70H50/4NMC lub CBT/CWBT70H50/...MC	BDFCH100/3,2NMC	CMP41H41/1MC
PANEL LENGTHS FROM 1800 TO 2100 mm CONSTRUCTION VARIANT A				
25°	CT70H50/3NMC lub CBT/CWBT70H50/...MC	CWT70H50/4,4NMC lub CBT/CWBT70H50/...MC	BDFCH120/3,6NMC	CMP41H41/1,5MC
30°	CT70H50/3NMC lub CBT/CWBT70H50/...MC	CWT70H50/4,4NMC lub CBT/CWBT70H50/...MC	BDFCH120/3,6NMC	CMP41H41/1,5MC
PANEL LENGTHS FROM 2100 TO 2300 mm CONSTRUCTION VARIANT B				
25°	CT70H50/3NMC lub CBT/CWBT70H50/...MC	CWT70H50/4,4NMC lub CBT/CWBT70H50/...MC	BDFCH120/4,4NMC	CMP41H41/1,2MC + CMP41H41/1,5MC
30°	CT70H50/3NMC lub CBT/CWBT70H50/...MC	CWT70H50/4,4NMC lub CBT/CWBT70H50/...MC	BDFCH120/4,4NMC	CMP41H41/1,2MC + CMP41H41/1,5MC

Dimensions of the structure depending on the angle of inclination of the structure and the size of the panels

Construction angle „a”	Distance „L1”	Height						Distance „U”
		„H1”	„H2”	„HK”	„HP”	„Hs1”	„Hs2”	
PANEL LENGTHS FROM 1600 TO 1700 mm CONSTRUCTION VARIANT A								
25°	2080	1020	1990	800	870		1030	300
30°	1680	1020	1990	700	730		1040	480
PANEL LENGTHS FROM 1700 TO 1800 mm CONSTRUCTION VARIANT A								
25°	2080	1020	1990	720	790		1030	500
30°	1680	1020	1990	650	730		1040	580
PANEL LENGTHS FROM 1800 TO 2100 mm CONSTRUCTION VARIANT A								
25°	2400	970	2100	660	730		1530	430
30°	2400	1020	2400	680	730		1600	440
PANEL LENGTHS FROM 2100 TO 2300 mm CONSTRUCTION VARIANT B								
25°	2630	1020	2240	650	720	650	1530	580
30°	2770	1020	2610	680	730	670	1600	440



Freestanding mounting structure for the installation of photovoltaic panels
System: W-H4G2-25° (optionally 30°)

ST

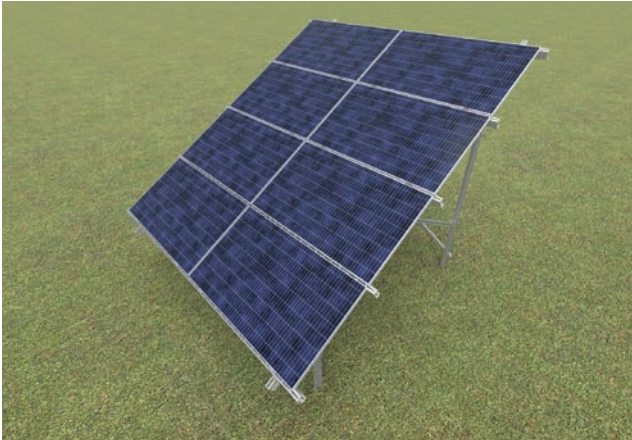

Structure description:

Complete support system for fixing four rows of panels in a horizontal arrangement.

Technical description:

Materials of the support system:
MC- Coated structural steel:
 Magnelis®, MagiZinc®, PosMAC
A- Aluminium
E- Stainless steel
F- Steel in zinc flake coating
 Structure tested for strength.

Arrangement of the modules:

· horizontal - H

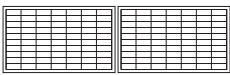

Structure assembly variants:

- **W-H4G2** structure - rammed into the ground (anchorage depth depends on ground conditions)
- **W-H4K2** structure - support posts anchored to the concrete foundation
- **W-H4B2** structure - support posts poured with concrete min. C16/20 in the holes made in the ground (size of the holes depends on the ground conditions)
- **W-H4S2** structure - on request, a screw screwed into the ground for fixing of the support posts
- **W-H4...2-WZ** structure - east-west option

Warranty:

BAKS provides a 10 year Warranty: period for the components included in the support structure - only if all conditions of the manufacturer's Warranty: are met. The Warranty: can be extended.

Ground conditions:

· soil with good/high load capacity

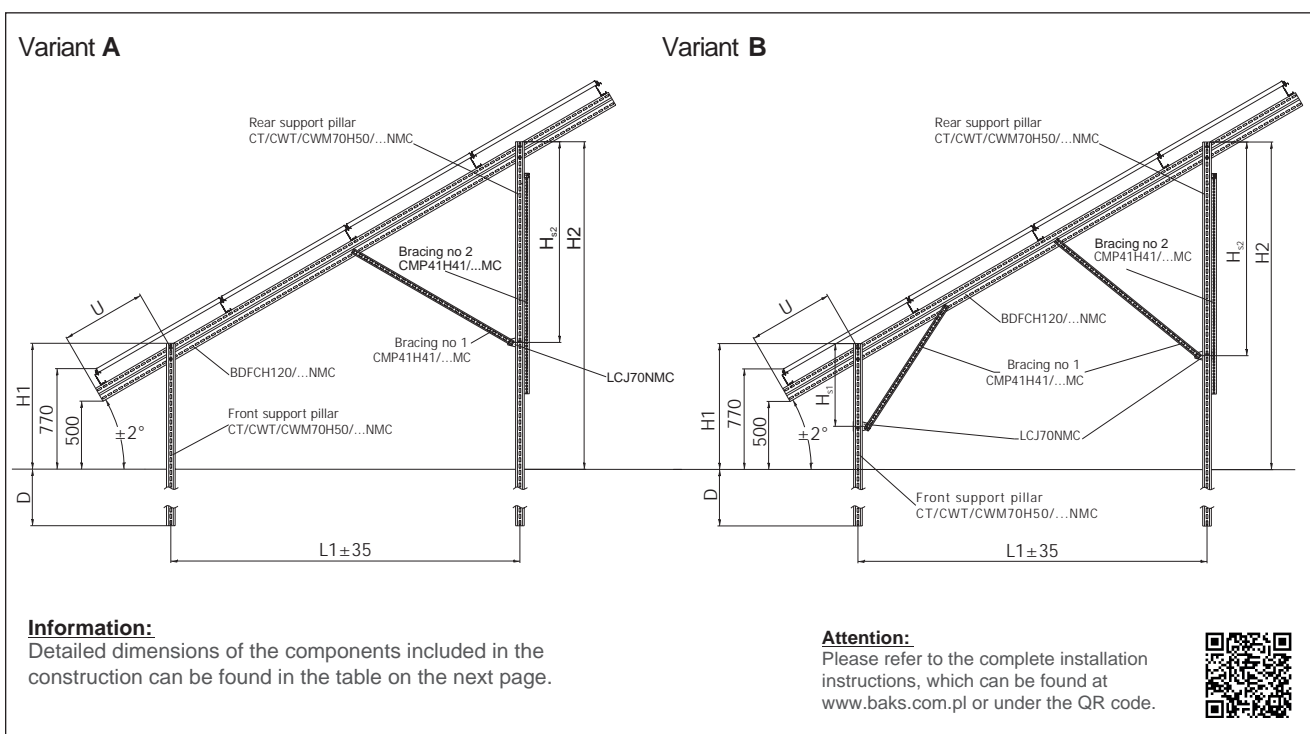



DIMENSIONS OF CONSTRUCTION - FREE-STANDING CONSTRUCTION

System: W-H4G2-25°

Lengths of construction elements depending on panel size

Construction angle „a”	Front support pillar	Rear support pillar	Rafter	Bracing No. 1
PANEL LENGTHS FROM 950 TO 1000 mm CONSTRUCTION VARIANT A				
25°	CWT70H50/3NMC lub CBT/CWBT70H50/...MC	CWT70H50/4,4NMC lub CBT/CWBT70H50/...MC	BDFCH120/4,4NMC	CMP41H41/1,5MC
30°	CWT70H50/3NMC lub CBT/CWBT70H50/...MC	CWT70H50/4,4NMC lub CBT/CWBT70H50/...MC	BDFCH120/4,NMC	CMP41H41/1,5MC
PANEL LENGTHS FROM 1000 TO 1150 mm CONSTRUCTION VARIANT A				
25°	CT70H50/3NMC lub CBT/CWBT70H50/...MC	CT70H50/4NMC lub CBT/CWBT70H50/...MC	BDFCH100/3,2NMC	CMP41H41/1,5MC
30°	CT70H50/3NMC lub CBT/CWBT70H50/...MC	CT70H50/4NMC lub CBT/CWBT70H50/...MC	BDFCH100/3,2NMC	CMP41H41/1,5MC
PANEL LENGTHS FROM 1150 TO 1300 mm CONSTRUCTION VARIANT B				
25°	CWT70H50/3NMC lub CBT/CWBT70H50/...MC	CWT70H50/4,4NMC lub CBT/CWBT70H50/...MC	BDFCH120/5,4NMC	CMP41H41/1,5MC + CMP41H41/2,2MC
30°	CWT70H50/3NMC lub CBT/CWBT70H50/...MC	CWT70H50/3NMC lub CBT/CWBT70H50/...MC	BDFCH120/5,4NMC	CMP41H41/1,5MC + CMP41H41/2,2MC

Dimensions of the structure depending on the angle of inclination of the structure and the size of the panels

Construction angle „a”	Distance „L1”	Height				Distance „U”
		„H1”	„H2”	„Hs1”	„Hs2”	
PANEL LENGTHS FROM 950 TO 1050 mm CONSTRUCTION VARIANT A						
25°	2820	870	2180		1520	580
30°	2520	970	2410		1620	690
PANEL LENGTHS FROM 1050 TO 1150 mm CONSTRUCTION VARIANT A						
25°	2960	950	2330		1520	780
30°	2830	970	2600		1620	690
PANEL LENGTHS FROM 1150 TO 1300 mm CONSTRUCTION VARIANT B						
25°	3370	950	2530	640	2340	780
30°	3450	970	2960	670	2440	690



Freestanding mounting structure for the installation of bifacial photovoltaic panels
System: W-V2G2-BI-25°

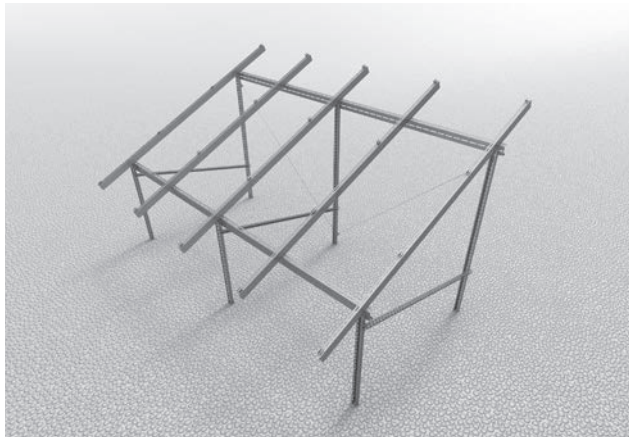

Structure description:

Complete support system for fixing bifacial panels, which use sunlight reflected from the ground.

Technical description:

Materials of the support system:
MC- Coated structural steel:
 Magnelis®, MagiZinc®, PosMAC
A- Aluminium
E- Stainless steel
F- Steel in zinc flake coating
 Overview design.

Arrangement of the modules:

· vertical - V

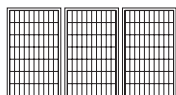

Ground conditions:

· soil with good/high load capacity

Advantages:

- the use of asymmetrical profiles with one side bent, allows a suitable construction angle and a plane prepared for direct installation of profiles on which the modules are to be placed
- the profiles with the bent side are mounted directly to the support columns without additional mounting elements
- made of Magnelis®

Structure assembly variants:

- **W-V2G2-BI** structure - rammed into the ground (anchorage depth depends on ground conditions)
- **W-V2K2-BI** structure - support posts anchored to the concrete foundation
- **W-V2B2-BI** structure - support posts poured with concrete min. C16/20 in the holes made in the ground (size of the holes depends on the ground conditions)
- **W-V2S2-BI** structure - on request, a screw screwed into the ground for fixing of the support posts

Warranty:

BAKS provides a 10 year Warranty: period for the components included in the support structure - only if all conditions of the manufacturer's Warranty: are met. The Warranty: can be extended.

By using supporting structure where the panel frames are or in the middle of the panel length (in the case of panels divided in half) and thanks to the bracings, it is possible to take full advantage of the efficiency of bifacial modules.

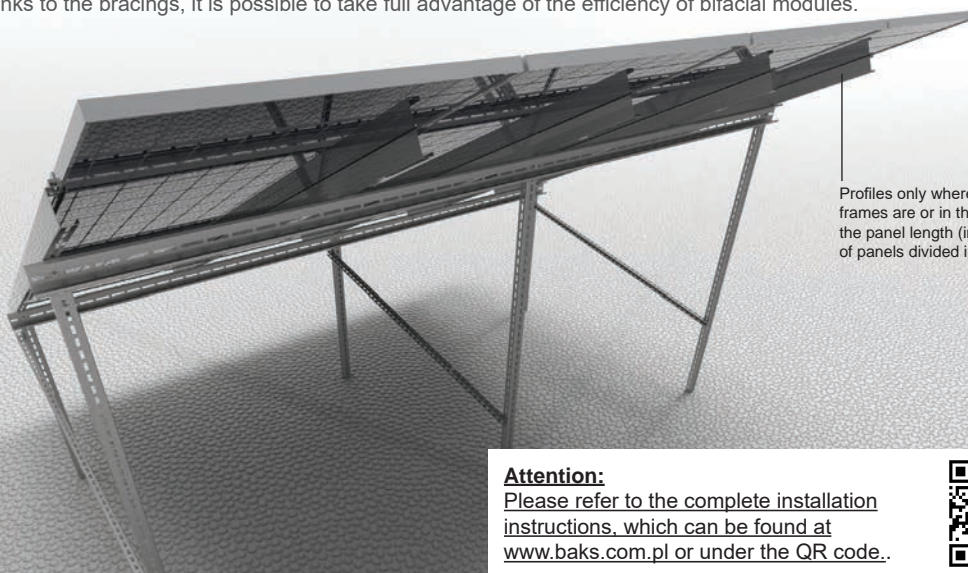

Profiles only where the panel frames are or in the middle of the panel length (in the case of panels divided in half)

Attention:

Please refer to the complete installation instructions, which can be found at www.baks.com.pl or under the QR code..





Freestanding mounting structure for the installation of photovoltaic panels
System: W-V2G1-25°

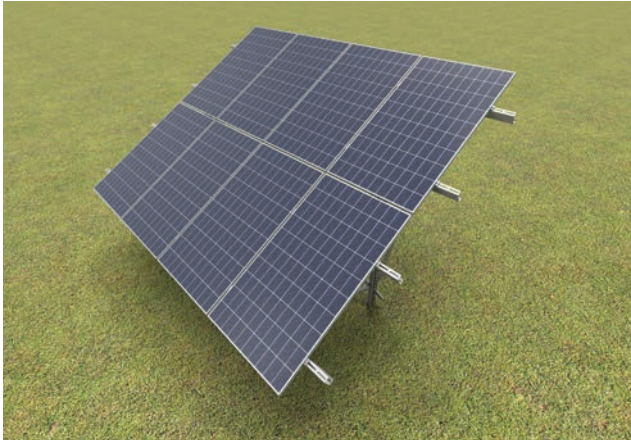

Structure description:

Complete support system for fixing two rows of panels in a vertical arrangement.

Technical description:

Materials of the support system:

- MC- Coated structural steel:
 - Magnelis®, MagiZinc®, PosMAC
 - A- Aluminium
 - E- Stainless steel
 - F- Steel in zinc flake coating
- Structure tested for strength.

Arrangement of the modules:

- vertical - V

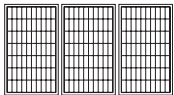

Ground conditions:

- soil with good/high load capacity

Structure assembly variants:

- W-V2G1 structure - rammed into the ground (anchorage depth depends on ground conditions)
- W-V2K1 structure - support posts anchored to the concrete foundation
- W-V2B1 structure - support posts poured with concrete min. C16/20, in the holes in the ground (size of the holes depends on the ground conditions) · konstrukcja
- W-V2S1 - na zamówienie śruba wkręcana w grunt do mocowania słupa podporowego
- W-V2...1-WZ structure - east-west option

Warranty:

BAKS provides a 10 year Warranty: period for the components included in the support structure - only if all conditions of the manufacturer's Warranty: are met. The Warranty: can be extended.

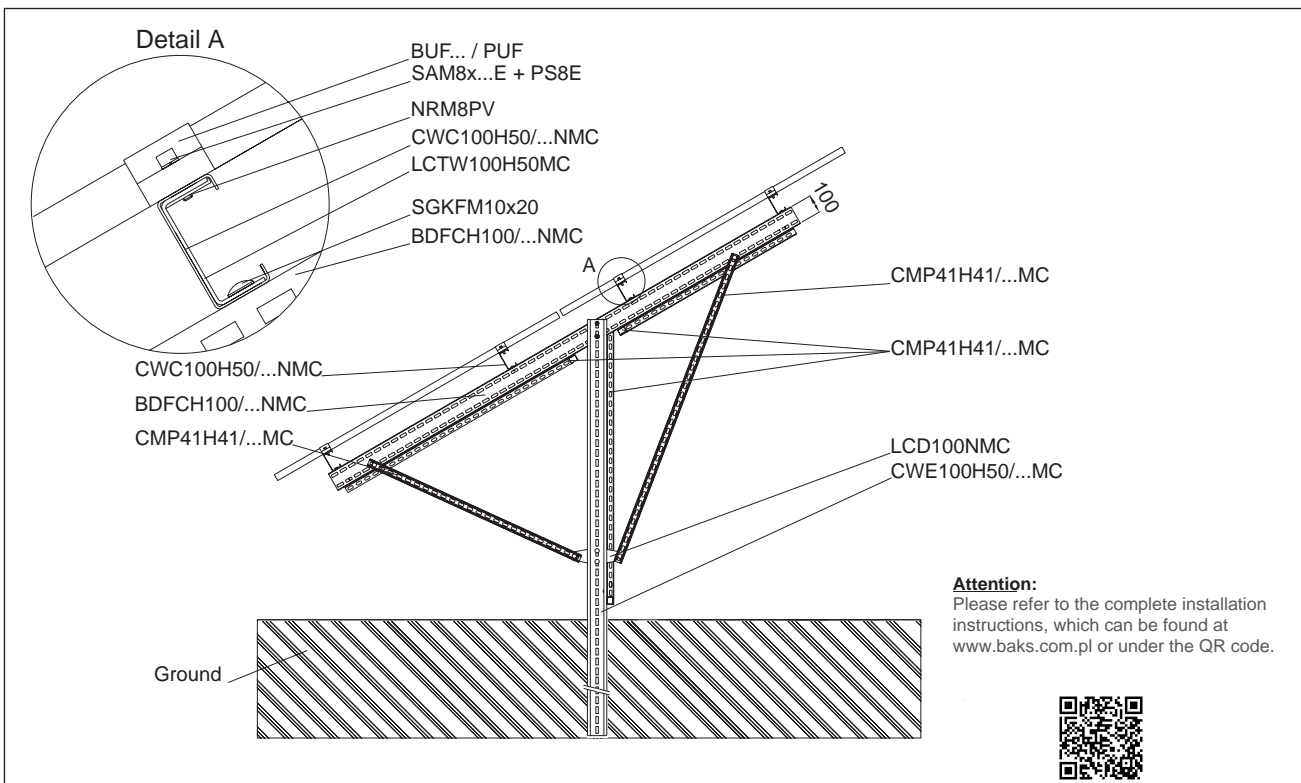

Detailed information on the products can be found on pages 80-174



Freestanding mounting structure for the installation of bifacial photovoltaic panels
System: W-H4G2-BI-25° (optionally 30°)

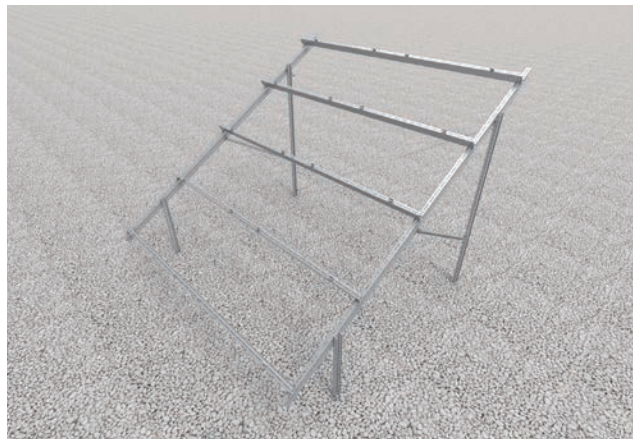
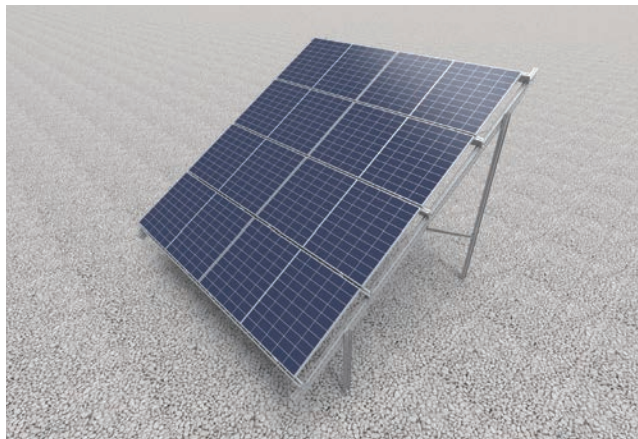

Structure description:

Complete support system for fixing bifacial panels, which use sunlight reflected from the ground.

Technical description:

Materials of the support system:
MC- Coated structural steel:
 Magnelis®, MagiZinc®, PosMAC
A- Aluminium
E- Stainless steel
F- Steel in zinc flake coating
 Overview design.

Arrangement of the modules:

· horizontal - H

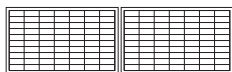

Ground conditions:

· soil with good/high load capacity

Advantages:

- Profiles where the panel frames are or in the middle of the panel length (in the case of panels divided in half)
- made of Magnelis®

Structure assembly variants:

- **W-H4G2-BI** structure - rammed into the ground (anchorage depth depends on ground conditions)
- **W-H4K2-BI** structure - support posts anchored to the concrete foundation
- **W-H4B2-BI** structure - support posts poured with concrete min. C16/20 in the holes made in the ground (size of the holes depends on the ground conditions)
- **W-H4S2-BI** structure - on request, a screw screwed into the ground for fixing of the support posts

Warranty:

BAKS provides a 10 year Warranty: period for the components included in the support structure - only if all conditions of the manufacturer's Warranty: are met. The Warranty: can be extended.

By using supporting structure where the panel frames are or in the middle of the panel length (in the case of panels divided in half), it is possible to take full advantage of the efficiency of bifacial modules.

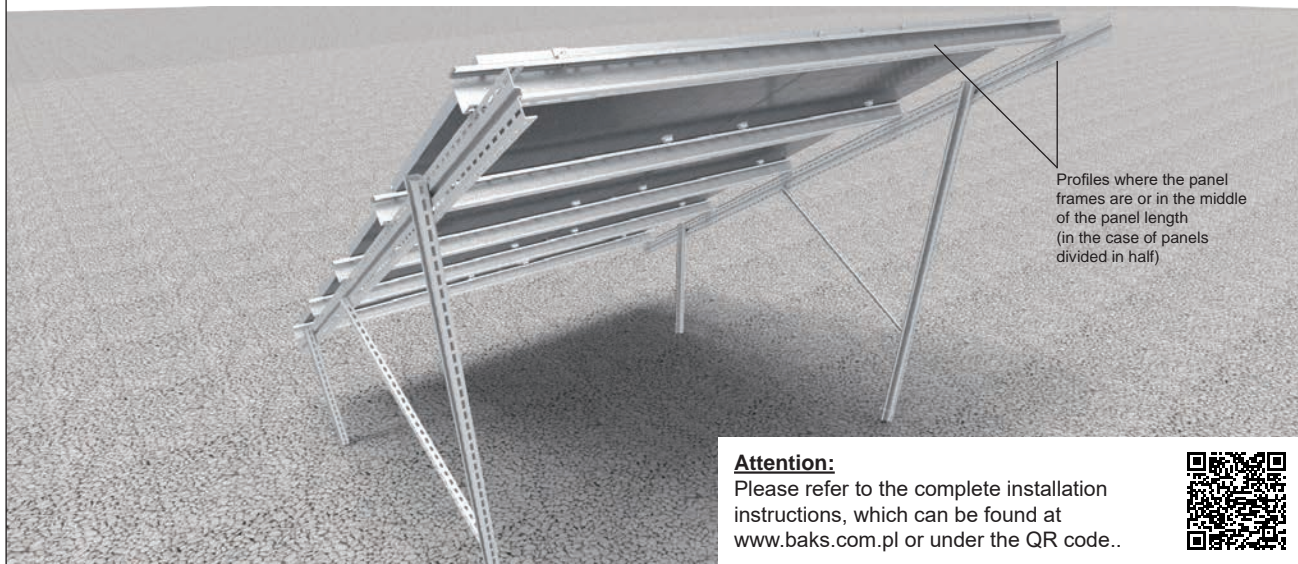

Attention:
 Please refer to the complete installation instructions, which can be found at www.baks.com.pl or under the QR code..



Detailed information on the products can be found on pages 80-174



Freestanding mounting structure for the installation of photovoltaic
System: W-V2G3-WZ-10°



Structure description:

A complete mounting system that allows for the installation of four vertical rows of panels facing east and west.

Technical description:

Materials of the support system:
MC- Coated structural steel:
 Magnelis®, MagiZinc®, PosMAC
A- Aluminium
E- Stainless steel
F- Steel in zinc flake coating
 Structure tested for strength.

Arrangement of the modules:

- vertical - V

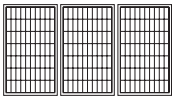

Ground conditions:

- soil with good/high load capacity

Structure assembly variants:

- **W-V2G3-WZ** structure driven into the ground (anchoring depth depends on ground conditions)
- **W-V2K3-WZ** structure - support columns anchored to the concrete foundation
- **W-V2B3-WZ** structure - support columns poured with concrete, min. C16/20, in holes drilled in the ground (hole size depends on ground conditions)
- **W-V2S3-WZ** design - on request, a screw screwed into the ground for attaching the support pole

Warranty:

BAKS provides a 10 year Warranty: period for the components included in the support structure - only if all conditions of the manufacturer's Warranty: are met. The Warranty: can be extended.

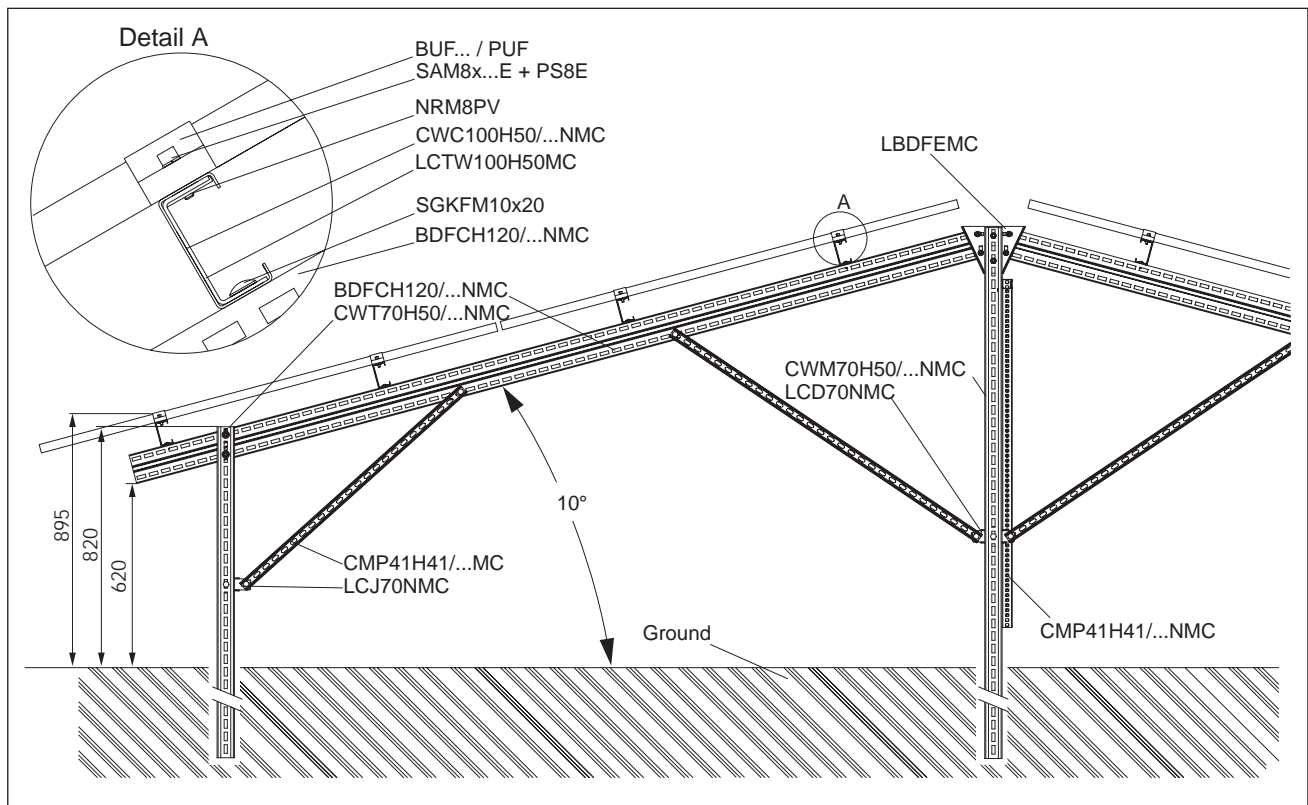

Detailed information on the products can be found on pages 80-174



Freestanding mounting structure for the installation of photovoltaic panels
System: W-V3G2-25°

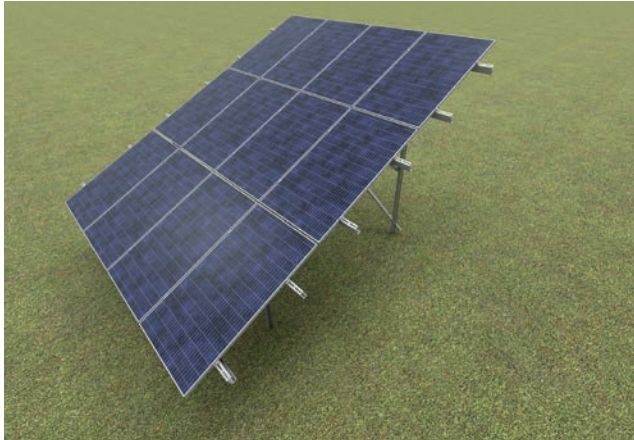

Structure description:

Complete support system for fixing three rows of panels in a vertical arrangement.

Technical description:

Materials of the support system:

- MC- Coated structural steel: Magnelis®, MagiZinc®, PosMAC
 - A- Aluminium
 - E- Stainless steel
 - F- Steel in zinc flake coating
- Structure tested for strength.

Arrangement of the modules:

- vertical - V

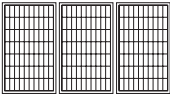

Ground conditions:

- soil with good/high load capacity

Structure assembly variants:

- W-V3G2 structure - rammed into the ground (anchorage depth depends on ground conditions)
- W-V3K2 structure - support posts anchored to the concrete foundation
- W-V3B2 structure - support posts poured with concrete min.C16/20 in the holes made in the ground (size of the holes depends on the ground conditions)
- W-V3S2 structure - on request, a screw screwed into the ground for fixing of the support post
- W-V3...2-WZ structure - east-west option

Warranty:

BAKS provides a 10 year Warranty: period for the components included in the support structure - only if all conditions of the manufacturer's Warranty: are met. The Warranty: can be extended.

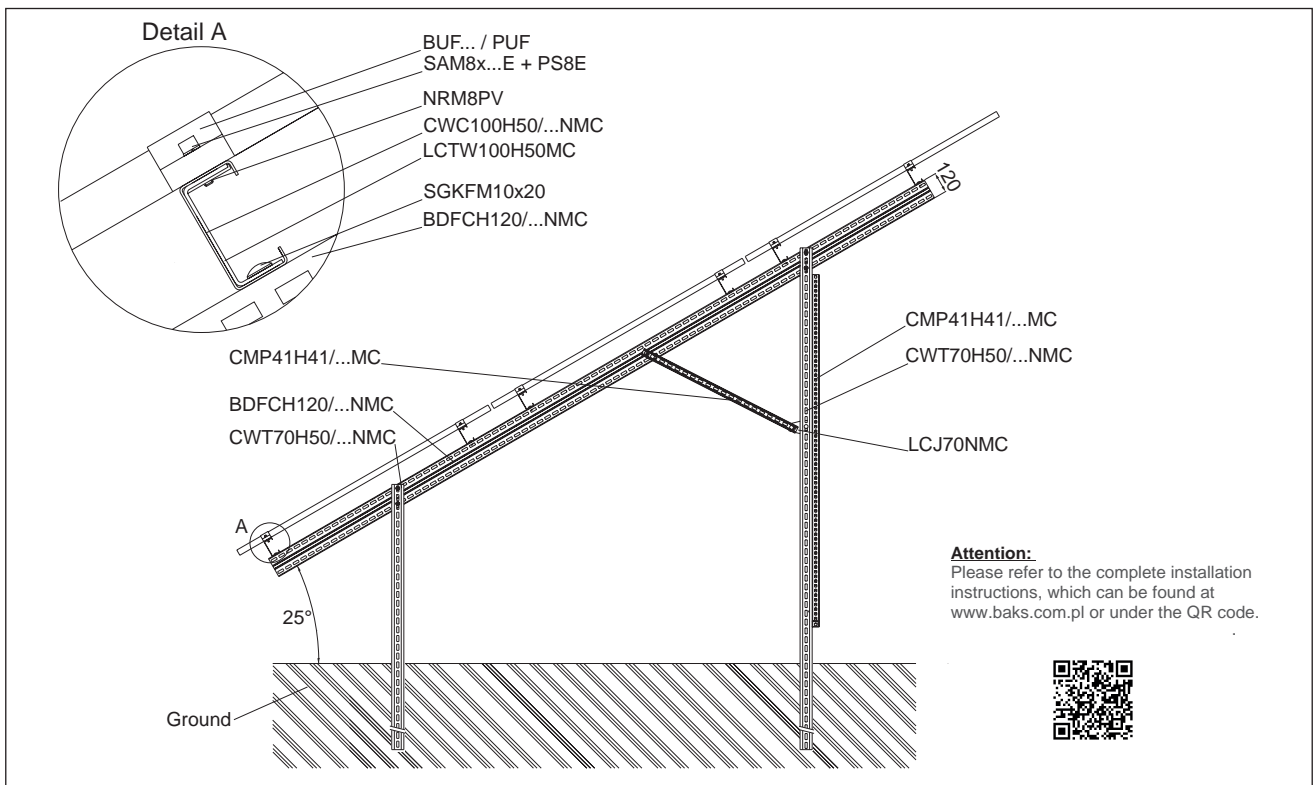

Detailed information on the products can be found on pages 80-174



Freestanding mounting structure for the installation of photovoltaic
System: W-H3G3-WZ-10°



Structure description:

A complete mounting system enabling the installation of six rows of panels in a horizontal arrangement, oriented east-west.

Technical description:

Materials of the support system:
MC- Coated structural steel:
 Magnelis®, MagiZinc®, PosMAC
A- Aluminium
E- Stainless steel
F- Steel in zinc flake coating
 Structure tested for strength.

Arrangement of the modules:

- horizontal - H

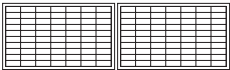

Ground conditions:

- soil with good/high load capacity

Structure assembly variants:

- W-H3G3-WZ** structure driven into the ground (anchoring depth depends on ground conditions)
- W-H3K3-WZ** structure - support columns anchored to the concrete foundation
- W-H3B3-WZ** structure - support columns poured with concrete, min. C16/20, in holes made in the ground (hole size depends on ground conditions)
- W-H3S3-WZ** design - on request, a screw screwed into the ground for attaching the support pole

Warranty:

BAKS provides a 10 year Warranty: period for the components included in the support structure - only if all conditions of the manufacturer's Warranty: are met. The Warranty: can be extended.

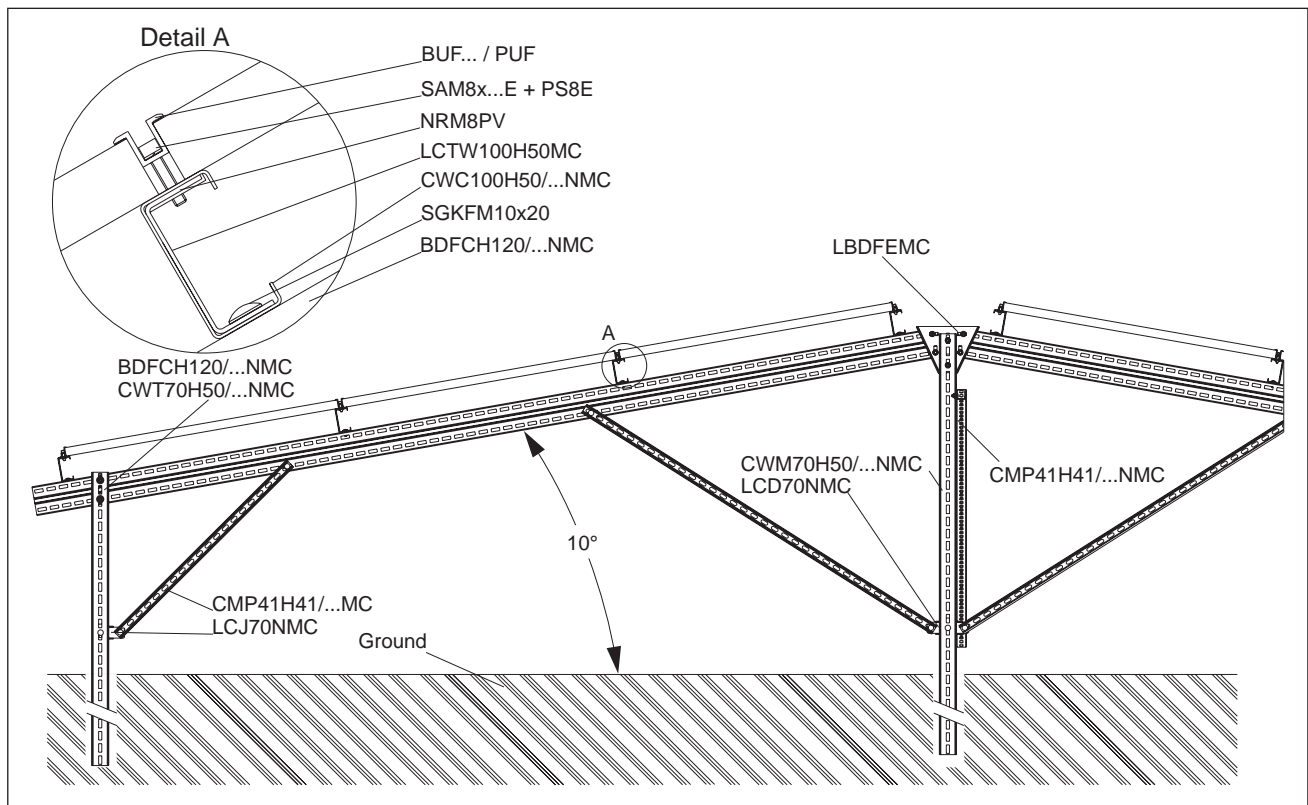

Detailed information on the products can be found on pages 80-174



Freestanding mounting structure for the installation of photovoltaic panels System: W-H5G2-25°

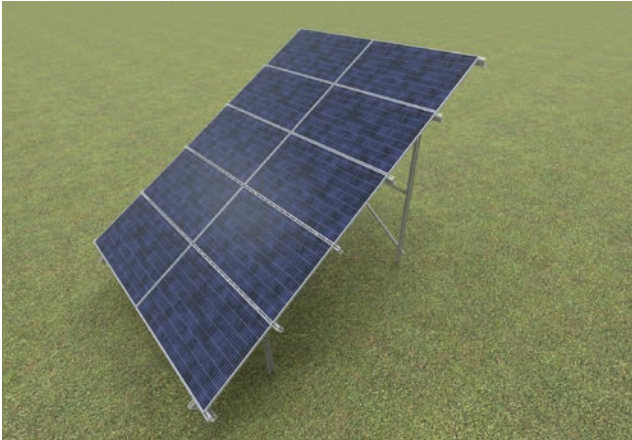

Structure description:

Complete support system for fixing five rows of panels in a horizontal arrangement.

Technical description:

Materials of the support system:

- MC- Coated structural steel: Magnelis®, MagiZinc®, PosMAC
 - A- Aluminium
 - E- Stainless steel
 - F- Steel in zinc flake coating
- Structure tested for strength.

Arrangement of the modules:

- horizontal - H

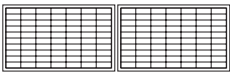

Ground conditions:

- soil with good/high load capacity

Structure assembly variants:

- W-H5G2 structure - rammed into the ground (anchorage depth depends on ground conditions)
- W-H5K2 structure - support posts anchored to the concrete foundation
- W-H5B2 structure - support posts poured with concrete min. C16/20 in the holes made in the ground (size of the holes depends on the ground conditions)
- W-H5S2 structure - on request, a screw screwed into the ground for fixing of the support posts
- W-H5...2-WZ structure - east-west option

Warranty:

BAKS provides a 10 year Warranty: period for the components included in the support structure - only if all conditions of the manufacturer's Warranty: are met. The Warranty: can be extended.

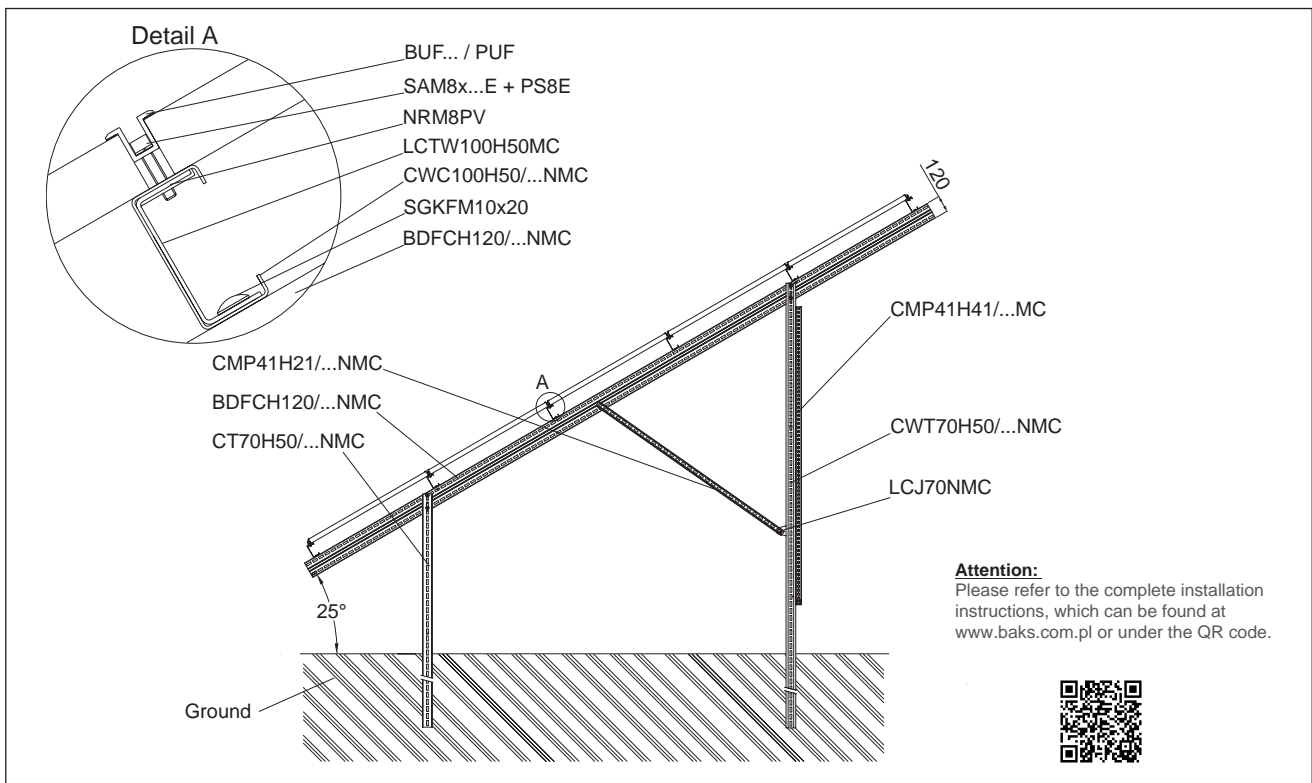

Detailed information on the products can be found on pages 80-174

Freestanding mounting structure for the installation of photovoltaic panels
System: W-H6G2-25°



Structure description:

Complete support system for fixing six rows of panels in a horizontal arrangement.

Technical description:

Materials of the support system:
MC- Coated structural steel:
 Magnelis®, MagiZinc®, PosMAC
A- Aluminium
E- Stainless steel
F- Steel in zinc flake coating
 Structure tested for strength.

Arrangement of the modules:

· horizontal - H

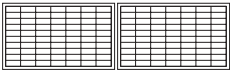

Ground conditions:

· soil with good/high load capacity

Structure assembly variants:

- **W-H6G2** structure - rammed into the ground (anchorage depth depends on ground conditions)
- **W-H6K2** structure - support posts anchored to the concrete foundation
- **W-H6B2** structure - support posts poured with concrete min. C16/20 in the holes made in the ground (size of the holes depends on the ground conditions)
- **W-H6S2** structure - on request, a screw screwed into the ground for fixing of the support posts
- **W-H6...2-WZ** structure - east-west option

Warranty:

BAKS provides a 10 year Warranty: period for the components included in the support structure - only if all conditions of the manufacturer's Warranty: are met. The Warranty: can be extended.

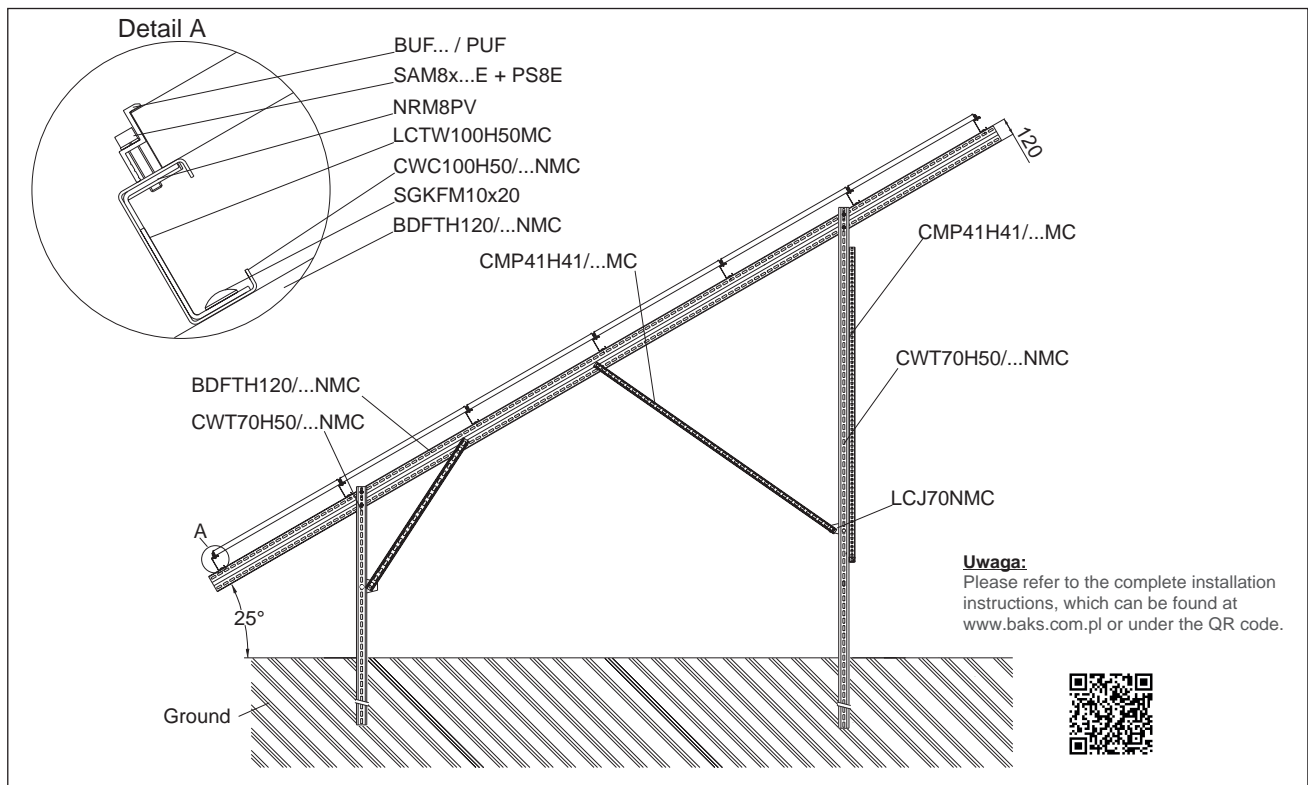

Detailed information on the products can be found on pages 80-174

Mounting structures for the installation of photovoltaic panels on sloping roofs

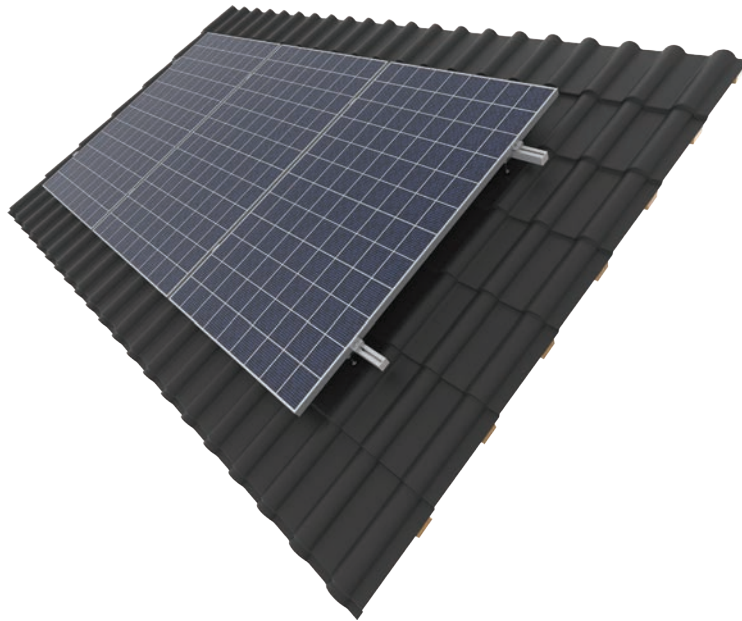

Structure systems for sloping roofs for different types of roof plating:

- metal tiles sheets or corrugated metal sheets, system: **DS-V1N, DS-H1N**
- sheet metal seam plates, system: **DS-V2N, DS-H2N**
- bituminous tiles, system: **DS-V3N, DS-H3N**
- ceramic tiles, system: **DS-V4N, DS-H4N**
- scale-shaped tiles, system: **DS-V5N, DS-H5N**
- trapezoidal metal sheets, system: **DS-V6aN, DS-H6aN, DS-V6bN, DS-H6bN, DS-V6cN, DS-H6cN**
- felt or membrane, system: **DS-V7N, DS-H7N**



Examples of system components:

 <p>Aluminum Profile PAL30H32..., PAL40H40...</p>	 <p>Panel mounts with grounding pad PUFP i BUFP...</p>	 <p>Aluminum Profile PAL40H80..., PAL40H120...</p>	 <p>Aluminum Mounting Rail SM... i SMA...</p>
 <p>Mounting rail connector LPSMA40, LPSMA</p>	 <p>Adjustable Roof Fixing DUR40E</p>	 <p>Adjustable Roof Fixing DUFR60E</p>	 <p>Adjustable Roof Fixing for Trapezoidal Sheet RUBTE</p>

Advantages of a structure for mounting photovoltaic panels on a pitched roof

- Modified aluminum profiles combined with click-type clamps significantly speed up installation
- Smooth adjustment and longitudinal perforation of the CWP40H35...MC profiles allow for easy and quick assembly of the structure, even on uneven roof surfaces
- Specially profiled handles ensure a stable and strong connection to the structure or roof covering
- all structure elements made of stainless steel are subjected to abrasive treatment, which guarantees an aesthetic appearance
- the structure elements are ready for use after taking them out of the packaging and do not require additional completion
- products made in Poland

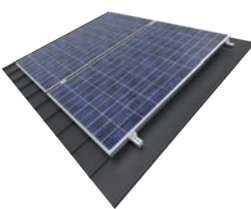
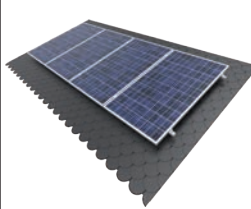
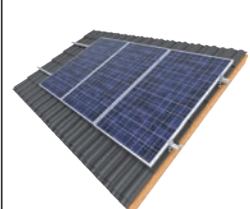
Systems:

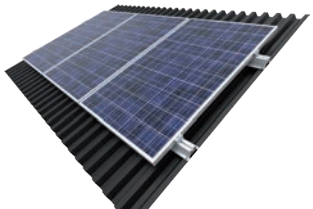
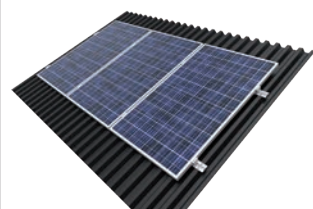
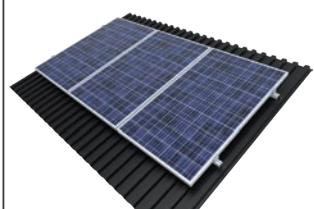
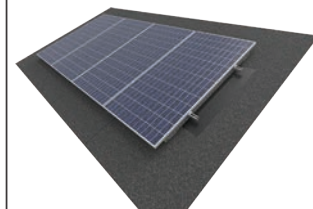
<p>metal roofing tiles</p>  <p>DS-V1N</p>	<p>seam sheet metal</p>  <p>DS-V2N</p>	<p>bituminous shingles</p>  <p>DS-V3N</p>	<p>ceramic and concrete tiles</p>  <p>DS-V4N</p>	<p>plain tiles</p>  <p>DS-V5N</p>
<p>trapezoidal sheet metal</p>  <p>DS-V6aN</p>	<p>trapezoidal sheet metal</p>  <p>DS-V6bN</p>	<p>trapezoidal sheet metal</p>  <p>DS-V6cN</p>	<p>roofing felt</p>  <p>DS-V7N</p>	

For inclined roofs covered with:

- ceramic and concrete tiles
- trapezoidal sheet metal
- metal roofing tiles
- plain tiles
- seam sheet metal
- bituminous shingles
- roofing felt
- membrane

It is possible to use profiles interchangeably:

- PAL40H40/... (aluminum)
- PAL30H32/... (aluminum)*
- *limited to 1 wind zone and 1, 2 and 3 snow zones
- CWP40H35/...MC (coated steel: Magnelis®, MagiZinc®, PosMAC)
- PAL40H80/... (aluminum)
- PAL40H120/... (aluminum)

Example:

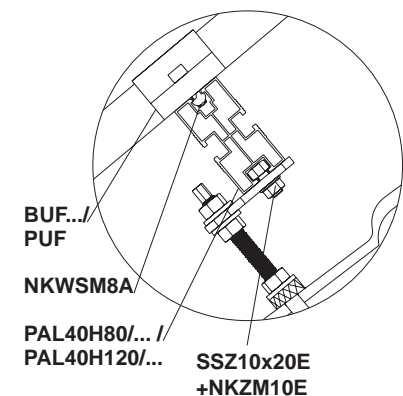
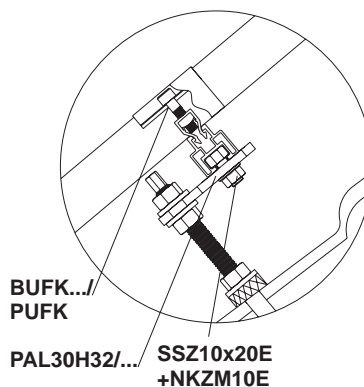
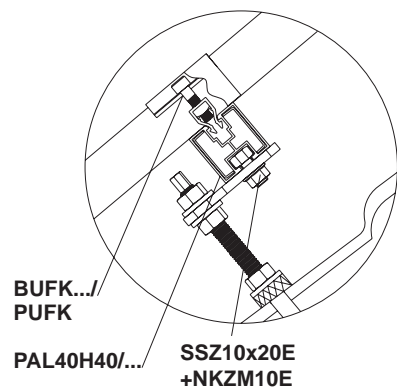
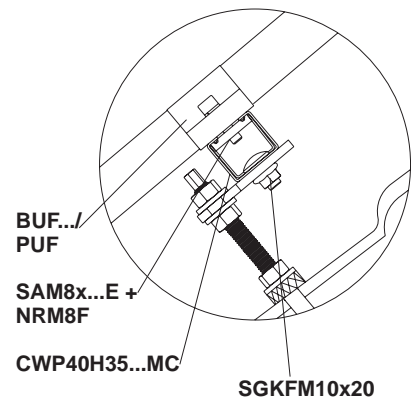
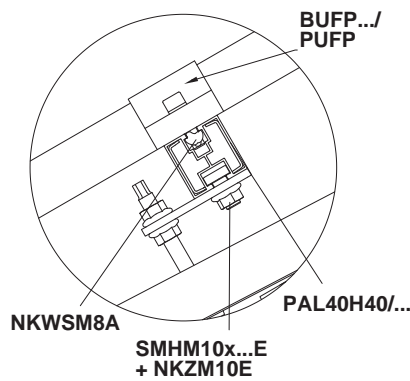
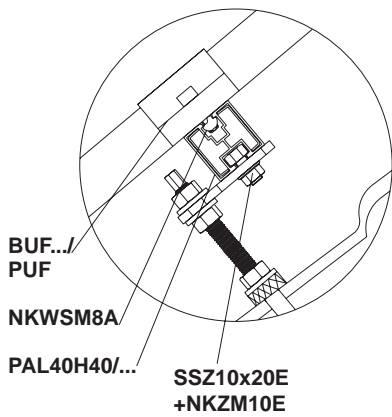
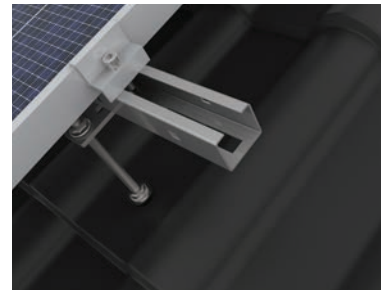
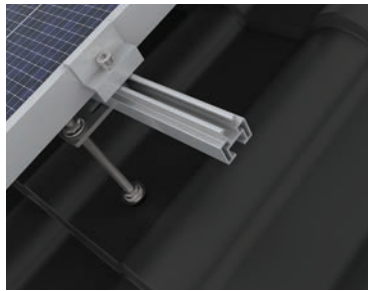
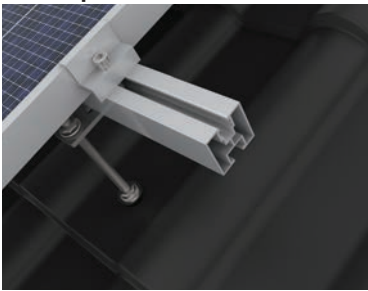



Mounting structure for the installation of photovoltaic panels on sloping roofs covered with metal tiles sheets or corrugated metal sheets
System: DS-V1N

ST

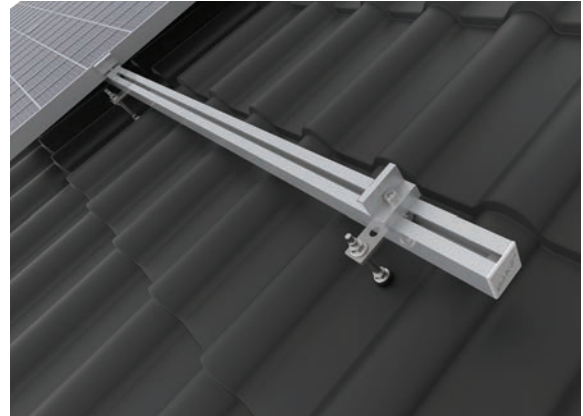
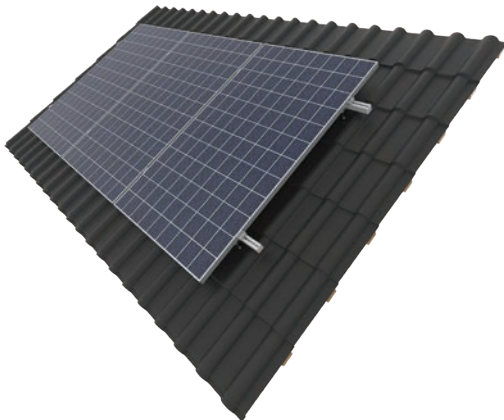

Structure description

Complete support system for any number of PV panels in a vertical arrangement on a sloping roof covered with metal tiles sheets or corrugated metal sheets

Technical description:

Materials of the support system:

A- Aluminium

E- Stainless steel

MC- Coated structural steel:

Magnelis®, MagiZinc®, PosMAC

Structure tested for strength.

Installation of double-threaded screws for roof rafters.

Design versions:

- Panel mounting profile PAL40H40
- Panel mounting profile PAL30H32
- Panel mounting profile CWP40H35...MC
- Panel mounting profile PAL40H80/...
- Panel mounting profile PAL40h120/...

Advantages:

- wide range of height adjustment of aluminium profiles in relation to the roof thanks to the long, threaded part of the screw
- additional adjustment of the aluminium profiles thanks to the longitudinal hole in the AD...E adapter
- the elements are made of stainless steel and aluminium, which guarantees very high corrosion resistance
- high stability of the structure thanks to the aluminium profile with a specially profiled section
- double-threaded screws fitted with rubber to ensure basic sealing of the hole in the roof tiles

Warranty

BAKS provides a 10 year warranty period for the components included in the support structure - only if all conditions of the manufacturer's warranty are met.

Układ modułów:

· horizontal - H

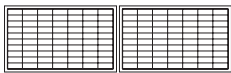

· vertical - V

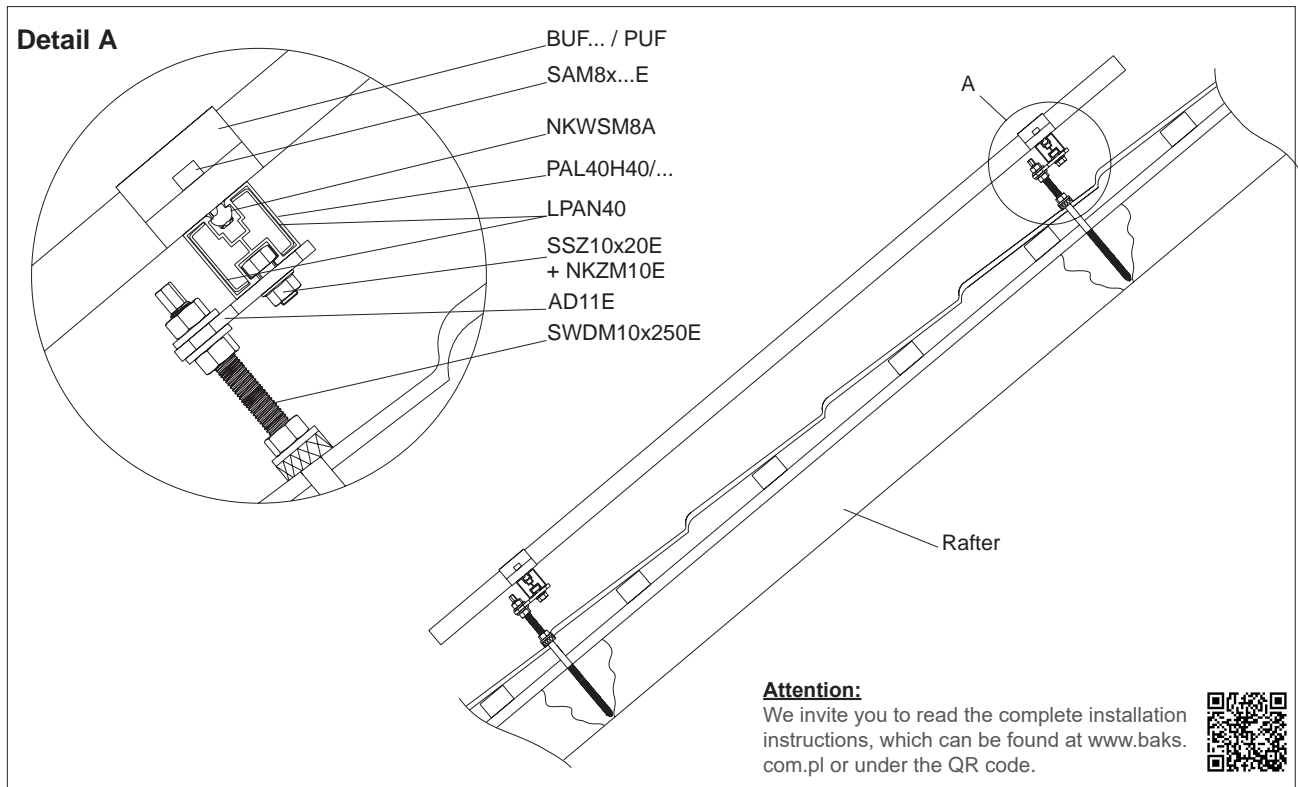
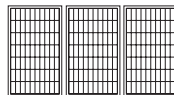

Attention:

We invite you to read the complete installation instructions, which can be found at www.baks.com.pl or under the QR code.



Mounting structure for the installation of photovoltaic panels on sloping roofs covered with sheet metal seam plates
System: DS-V2N

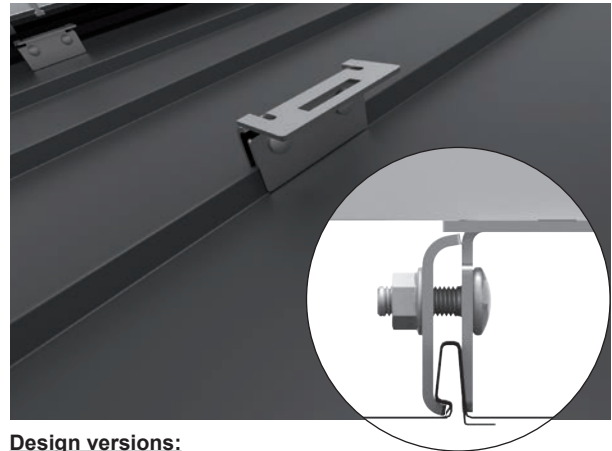
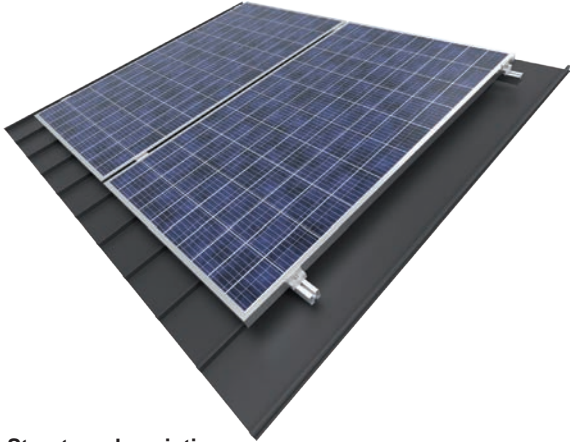

Structure description

Complete support system for any number of PV panels in a vertical arrangement on a sloping roof covered with sheet metal seam plates

Technical description:

Materials of the support system:

A- Aluminium

E- Stainless steel

MC- Coated structural steel:

Magnelis®, MagiZinc®, PosMAC

Structure tested for strength.

The holders should be mounted to the first three seams, counted from the edge of each row of panels and then every second seam.

Arrangement of the modules:

· horizontal - H

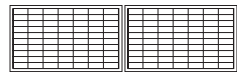

· vertical - V

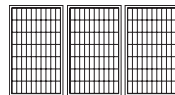

Design versions:

- Panel mounting profile PAL40H40
- Panel mounting profile PAL30H32
- Panel mounting profile CWP40H35...MC
- Panel mounting profile PAL40H80/...
- Panel mounting profile PAL40h120/...

Advantages:

- installation of the structure to the seam without interfering with the structure of the roofing
- quick installation of the holders without the need to locate the rafters
- different versions of holders for sheets metal to ensure stable installation with most sheet metal seam plates systems
- the elements are made of stainless steel and aluminium, which guarantees very high corrosion resistance
- high stability of the structure thanks to the aluminium profile with a specially profiled section

Warranty

BAKS provides a 10 year warranty period for the components included in the support structure - only if all conditions of the manufacturer's warranty are met.

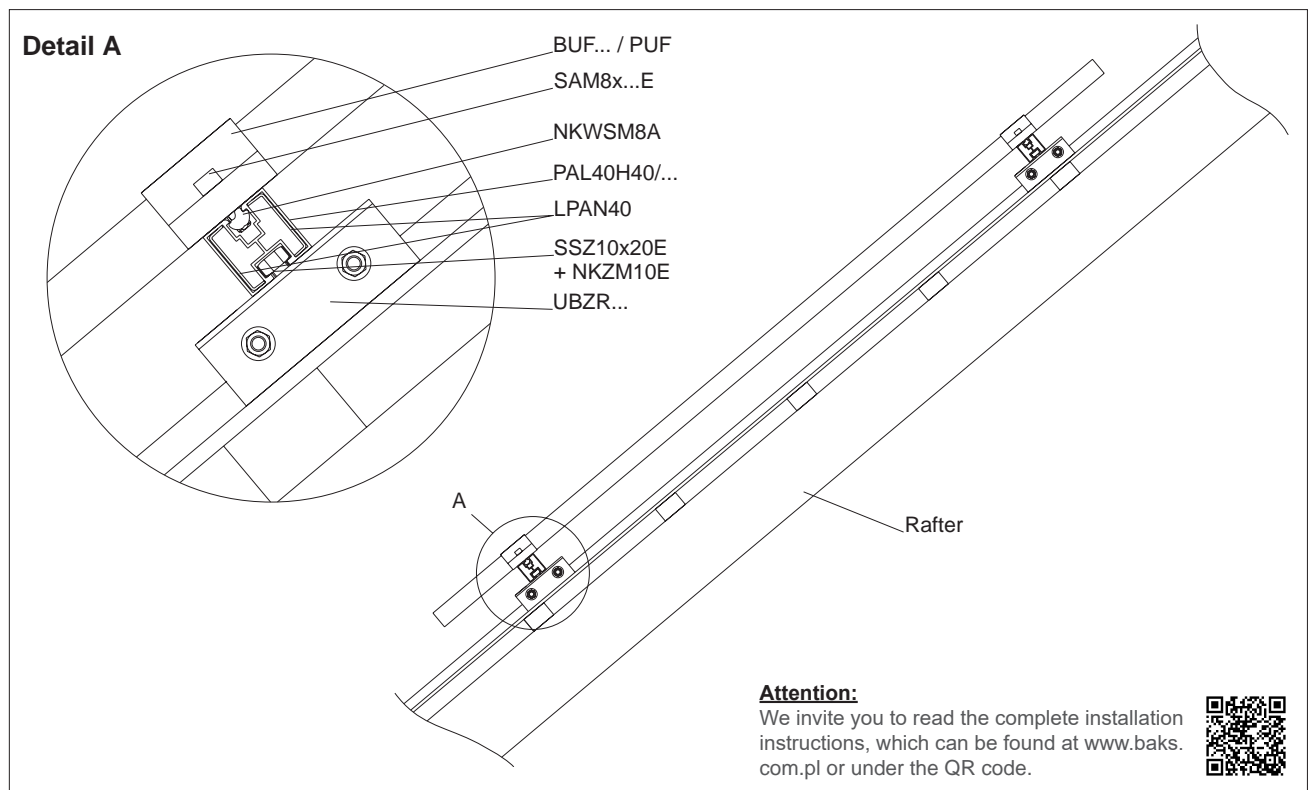

Attention:

We invite you to read the complete installation instructions, which can be found at www.baks.com.pl or under the QR code.





Mounting structure for the installation of photovoltaic panels on sloping roofs covered with bituminous tiles
System: DS-V3N

ST

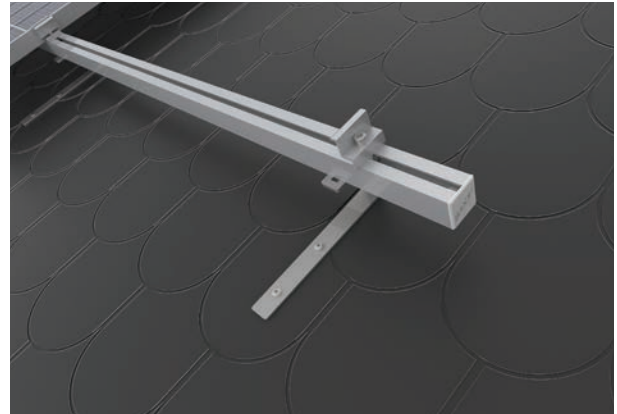
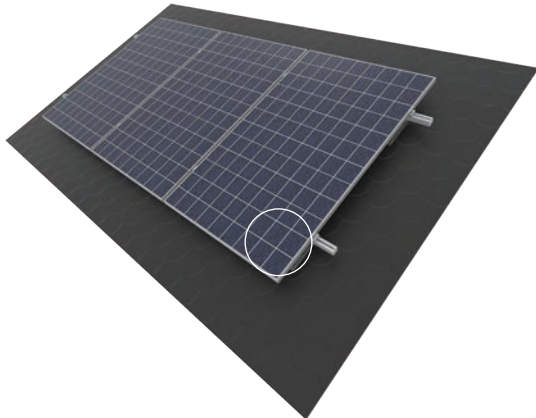

Structure description

Complete support system for any number of PV panels in a vertical arrangement on a sloping roof covered with bituminous tiles

Technical description:

Materials of the support system:

A- Aluminium

E- Stainless steel

MC- Coated structural steel:

Magnelis®, MagiZinc®, PosMAC

Structure tested for strength.

Installation of holders with screws for roof rafters.

Arrangement of the modules:

· horizontal - H

· vertical - V

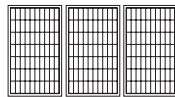
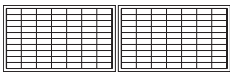

Design versions:

- Panel mounting profile **PAL40H40**
- Panel mounting profile **PAL30H32**
- Panel mounting profile **CWP40H35...MC**
- Panel mounting profile **PAL40H80/...**
- Panel mounting profile **PAL40h120/...**

Advantages:

- the shape of the holders ensures high stability of the structure
- the elements are made of stainless steel and aluminium, which guarantees very high corrosion resistance
- high stability of the structure thanks to the aluminium profile with a specially profiled section
- thanks to the use of a channel, it is possible to route cables inside it

Warranty

BAKS provides a 10 year warranty period for the components included in the support structure - only if all conditions of the manufacturer's warranty are met..

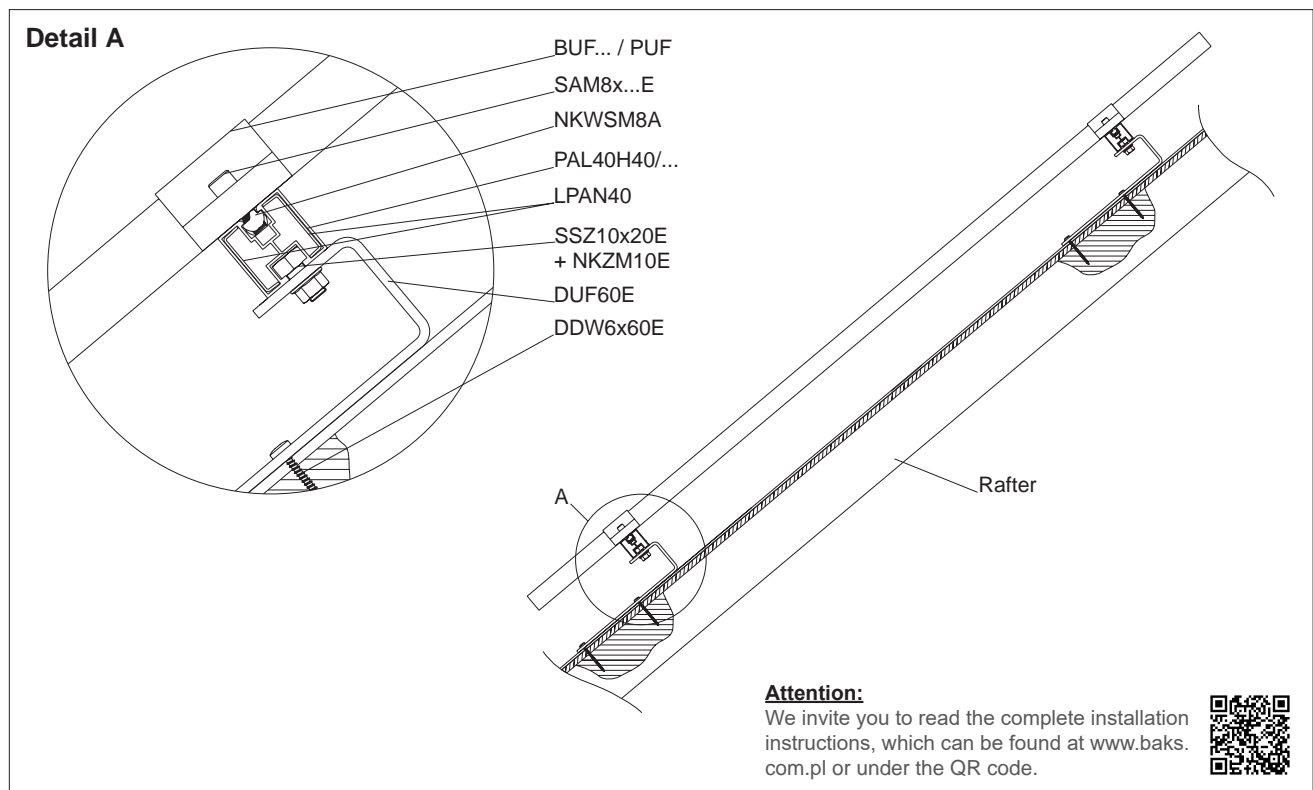

Attention:

We invite you to read the complete installation instructions, which can be found at www.baks.com.pl or under the QR code.





Mounting structure for the installation of photovoltaic panels on sloping roofs covered with bituminous tiles
System: DS-V4N

ST

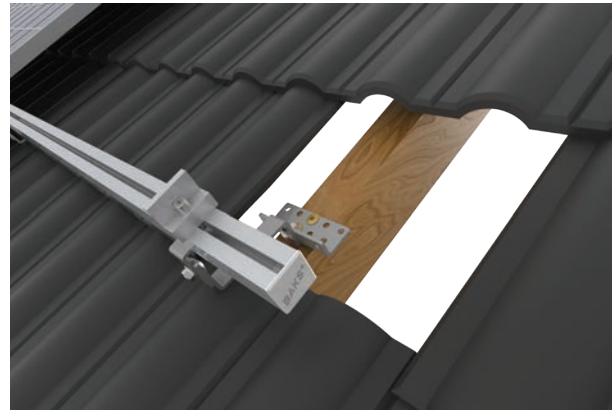
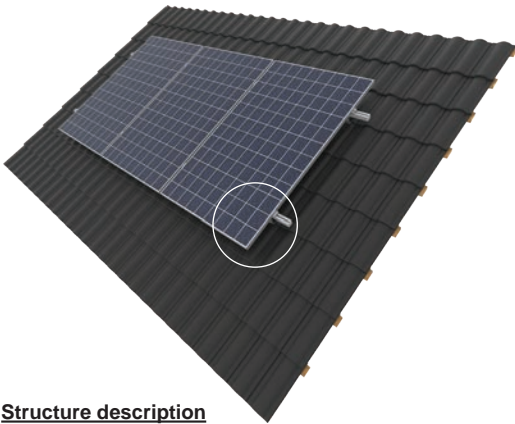

Structure description

Complete support system for any number of PV panels in a vertical arrangement on a sloping roof covered with ceramic or concrete tiles

Technical description:

Materials of the support system:

A- Aluminium

E- Stainless steel

MC- Coated structural steel:

Magnelis®, MagiZinc®, PosMAC

Structure tested for strength.

Installation of holders with screws for roof rafters.

Design versions:

- Panel mounting profile PAL40H40
- Panel mounting profile PAL30H32
- Panel mounting profile CWP40H35...MC
- Panel mounting profile PAL40H80/...
- Panel mounting profile PAL40h120/...

Arrangement of the modules:

· horizontal - H

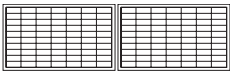

· vertical - V

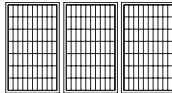

Advantages:

- wide adjustment range of the holders thanks to longitudinal holes in each of the 3 elements of the holder
- dense perforation in the part directly adjacent to the roof truss ensure that the holder can be adjusted and correctly positioned in relation to the tiles so that the hook is in the middle of the tile mounted below
- elongated middle arm of the holder allows the hooks to be mounted on the majority of ceramic and concrete roof tiles available on the market
- the elements are made of stainless steel and aluminium, which guarantees very high corrosion resistance
- high stability of the structure thanks to the aluminium profile with a specially profiled section

Warranty

BAKS provides a 10 year warranty period for the components included in the support structure - only if all conditions of the manufacturer's warranty are met.

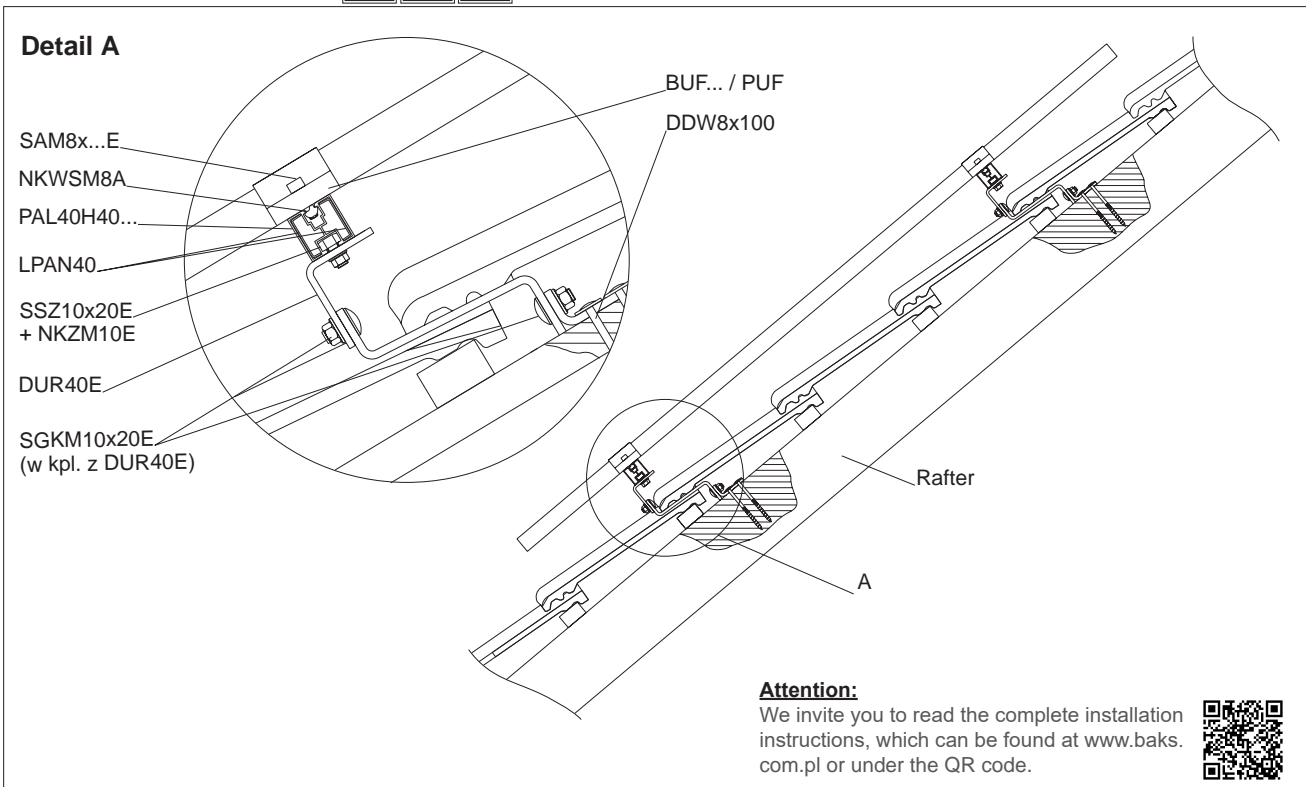

Attention:

We invite you to read the complete installation instructions, which can be found at www.baks.com.pl or under the QR code.





Mounting structure for the installation of photovoltaic panels on sloping roofs covered with scale-shaped tiles
System: DS-V5N

ST

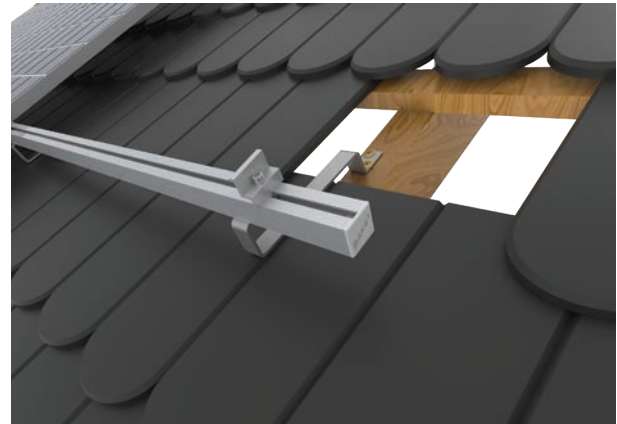
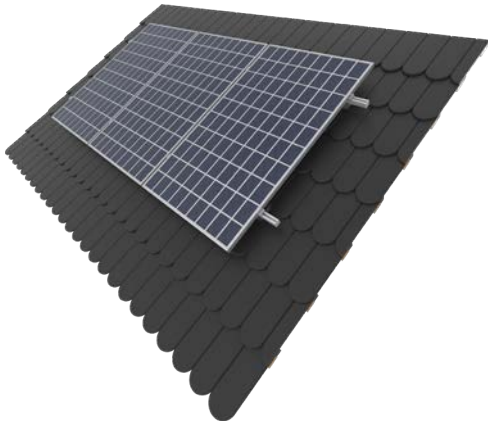

Structure description

Complete support system for any number of PV panels in a vertical arrangement on a sloping roof covered with scale-shaped tiles.

Technical description:

Materials of the support system:

A- Aluminium

E- Stainless steel

MC- Coated structural steel:

Magnelis®, MagiZinc®, PosMAC

Structure tested for strength.

Installation of holders with screws for roof rafters.

Arrangement of the modules:

· horizontal - H

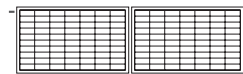

· vertical - V

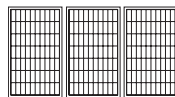

Design versions:

- Panel mounting profile PAL40H40
- Panel mounting profile PAL30H32
- Panel mounting profile CWP40H35...MC
- Panel mounting profile PAL40H80/...
- Panel mounting profile PAL40h120/...

Advantages:

- elongated arm of the holder allows the hooks to be mounted on the majority of ceramic and concrete roof tiles available on the market
- the elements are made of stainless steel and aluminium, which guarantees very high corrosion resistance
- high stability of the structure thanks to the aluminium profile with a specially profiled section

Warranty

BAKS provides a 10 year warranty period for the components included in the support structure - only if all conditions of the manufacturer's warranty are met.

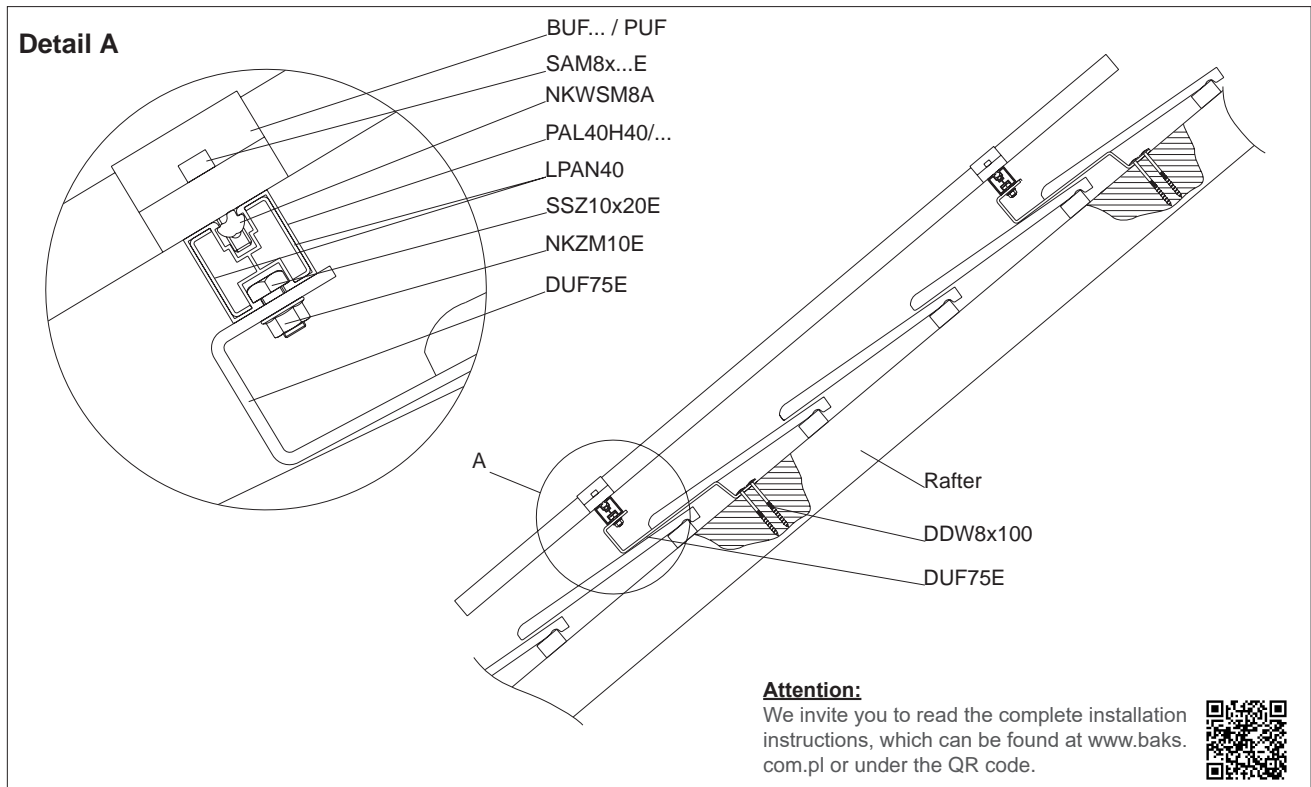

Attention:

We invite you to read the complete installation instructions, which can be found at www.baks.com.pl or under the QR code.





Mounting structure for the installation of photovoltaic panels on sloping roofs covered with trapezoidal metal sheets - high rail
System: DS-V6aN

ST

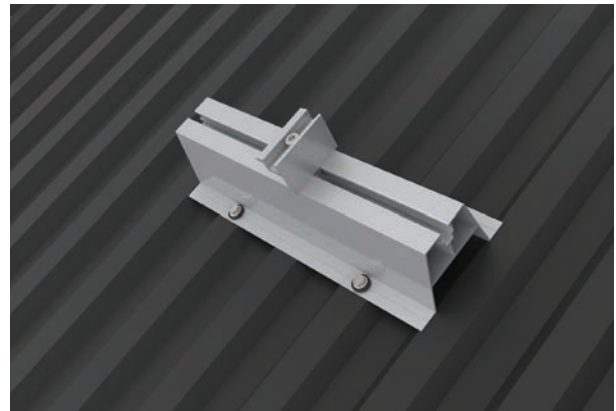
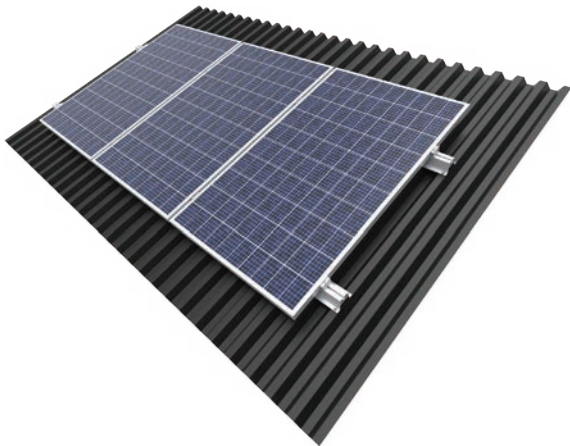

Structure description

Complete support system for any number of PV panels in a vertical arrangement on a sloping roof covered with trapezoidal metal sheets.

Technical description:

Materials of the support system:

A- Aluminium

E- Stainless steel

Structure tested for strength.

Mounting sheet metal brackets.

Arrangement of the modules:

· horizontal - H

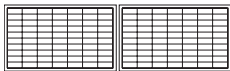

· vertical - V

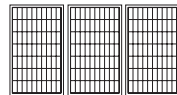

Advantages:

- quick installation of the structure with threaded screws directly to the trapezoidal metal sheets without the need to locate the rafters
- very economical design with a small number of components
- the elements are made of stainless steel and aluminium, which guarantees very high corrosion resistance
- high stability of the structure thanks to the aluminium profile with a specially profiled section

Warranty

BAKS provides a 10 year warranty period for the components included in the support structure - only if all conditions of the manufacturer's warranty are met.

Detail A

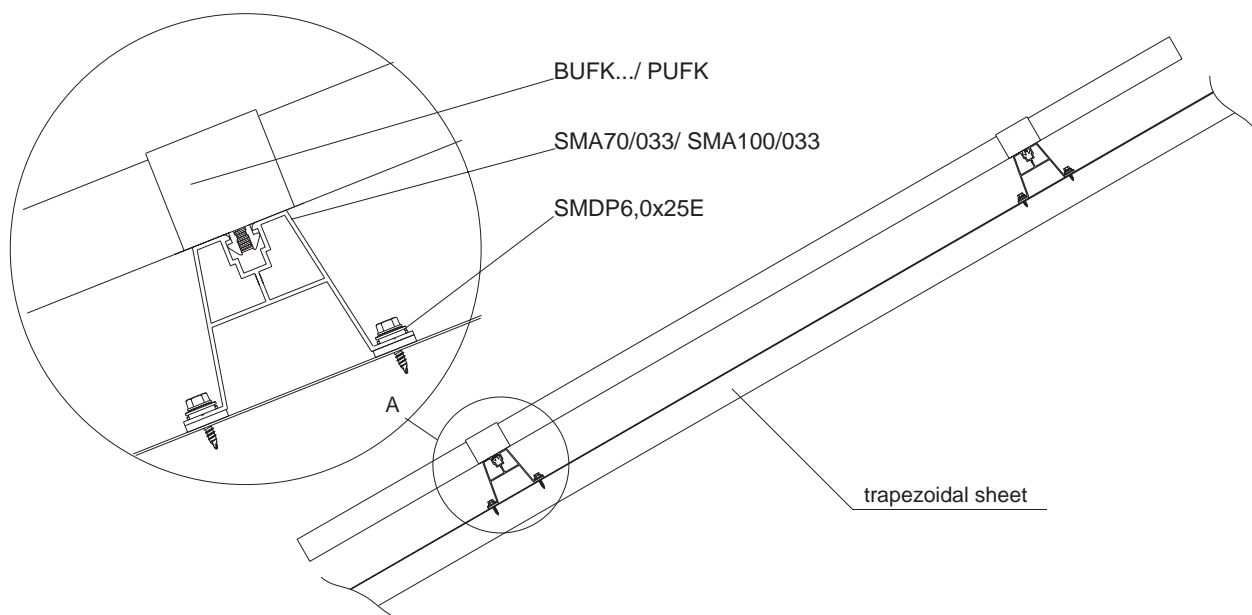

Attention:

We invite you to read the complete installation instructions, which can be found at www.baks.com.pl or under the QR code.





Mounting structure for the installation of photovoltaic panels on sloping roofs covered with trapezoidal metal sheets - low rail
System: DS-V6bN

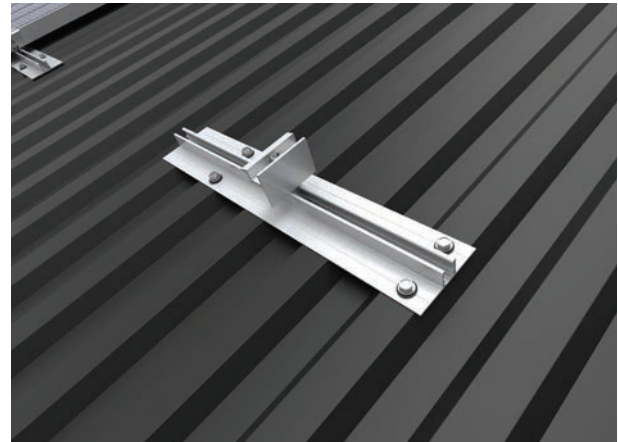
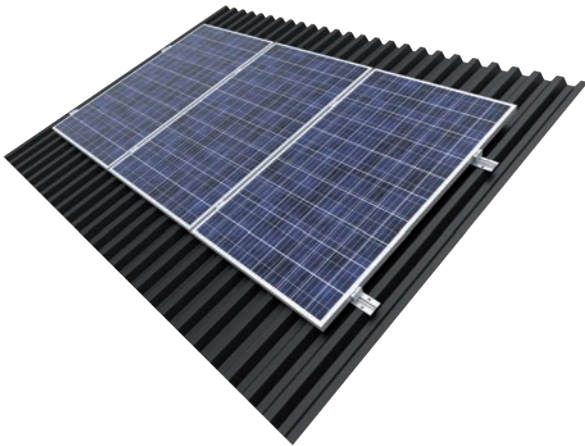

Structure description

Complete support system for any number of PV panels in a vertical arrangement on a sloping roof covered with trapezoidal metal sheets..

Technical description:

Materials of the support system:

A- Aluminium

E- Stainless steel

Structure tested for strength.

Mounting sheet metal brackets.

Advantages:

- quick installation of the structure with threaded screws directly to the trapezoidal metal sheets without the need to locate the rafters
- very economical design with a small number of components
- the elements are made of stainless steel and aluminium, which guarantees very high corrosion resistance
- high stability of the structure thanks to the aluminium profile with a specially profiled section

Warranty

BAKS provides a 10 year warranty period for the components included in the support structure - only if all conditions of the manufacturer's warranty are met.

Arrangement of the modules:

· horizontal - H

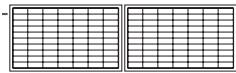

· vertical - V

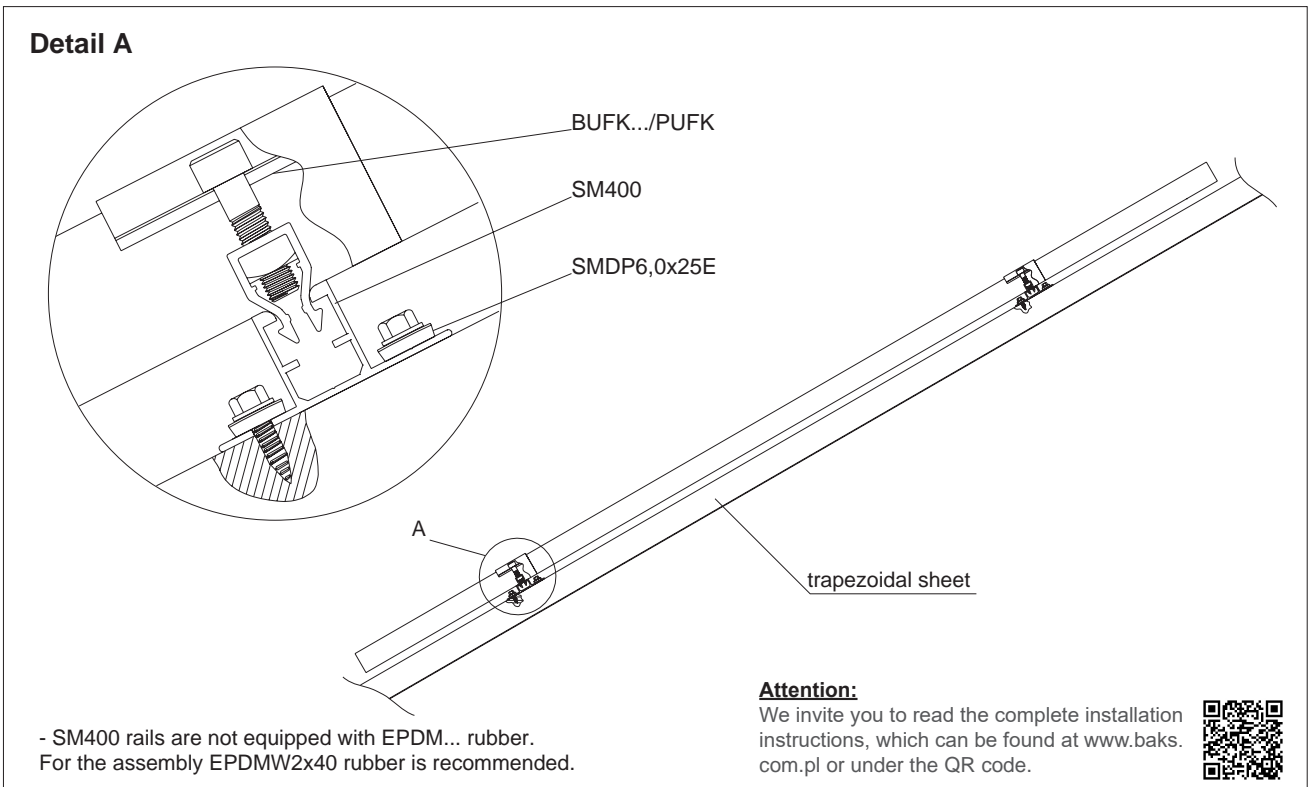
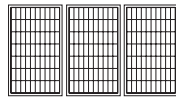



Mounting structure for the installation of photovoltaic panels on sloping roofs covered with trapezoidal metal sheets

System: DS-V6cN

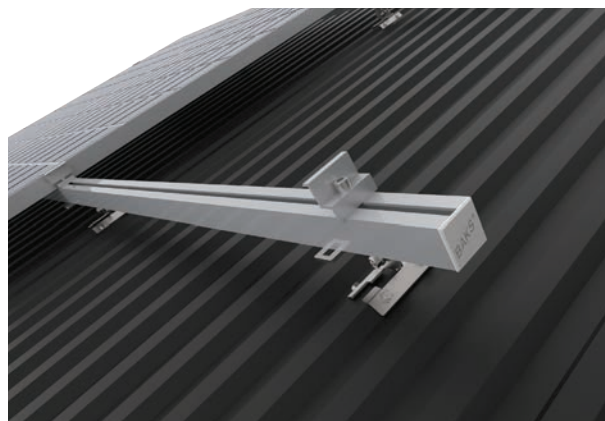
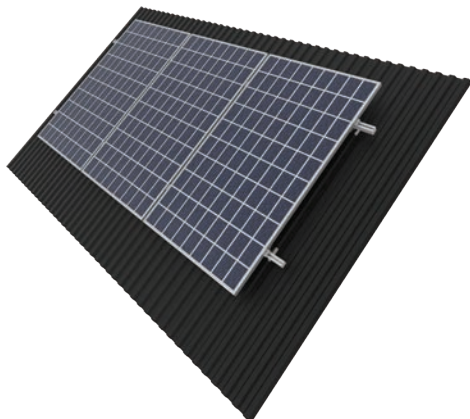

Structure description

Complete support system for any number of PV panels in a vertical arrangement on a sloping roof covered with trapezoidal metal sheets.

Technical description:

Materials of the support system:

A- Aluminium

E- Stainless steel

MC- Coated structural steel:

Magnelis®, MagiZinc®, PosMAC

Structure tested for strength.

Mounting sheet metal brackets.

Arrangement of the modules:

· horizontal - H

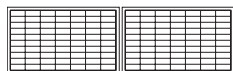

· vertical - V

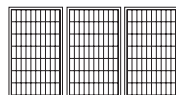

Design versions:

- Panel mounting profile PAL40H40

- Panel mounting profile PAL30H32

- Panel mounting profile CWP40H35...MC

- Panel mounting profile PAL40H80/...

- Panel mounting profile PAL40h120/...

Advantages:

- quick installation of the structure with threaded screws directly to the trapezoidal metal sheets without the need to locate the rafters

- very economical design with a small number of components-

- the elements are made of stainless steel and aluminium,

which guarantees very high corrosion resistance

- high stability of the structure thanks to the aluminium profile

with a specially profiled section

· wide adjustment range allows for adaptation to various trapezoidal sheets ranging from 20 to 85 mm in width

Warranty

BAKS provides a 10 year warranty period for

the components included in the support structure

- only if all conditions of the manufacturer's

warranty are met.

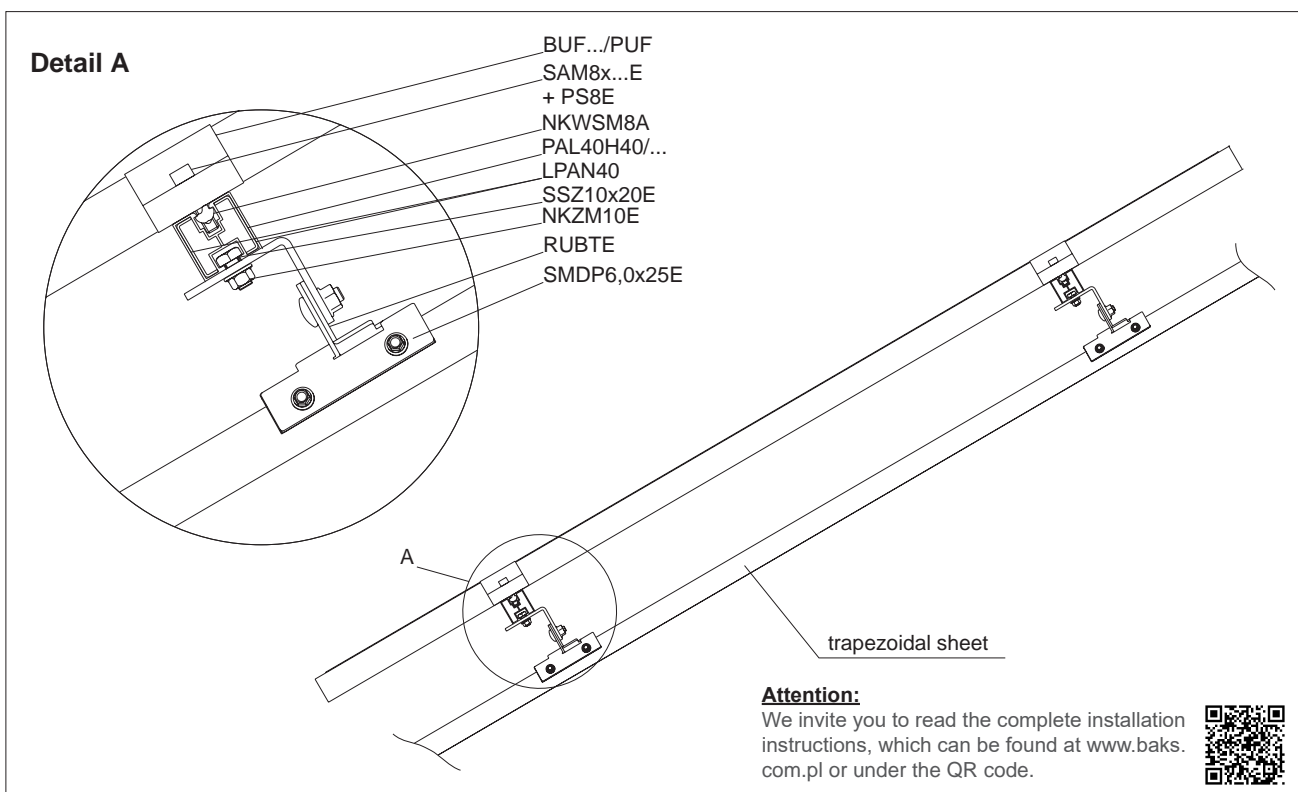

Detailed information on the products can be found on pages 80-174



Mounting structure for the installation of photovoltaic panels on a inclined roof covered with roofing felt or membrane
System: DS-V7N

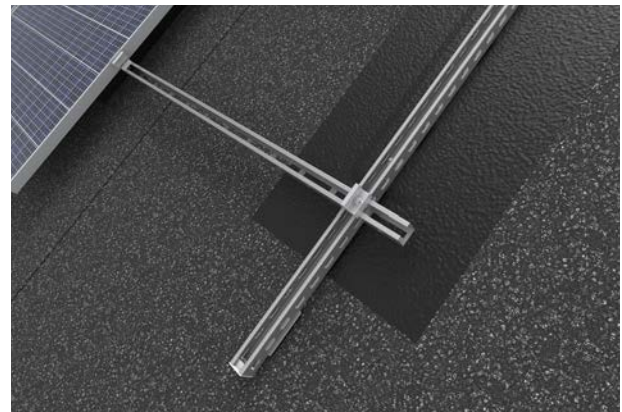
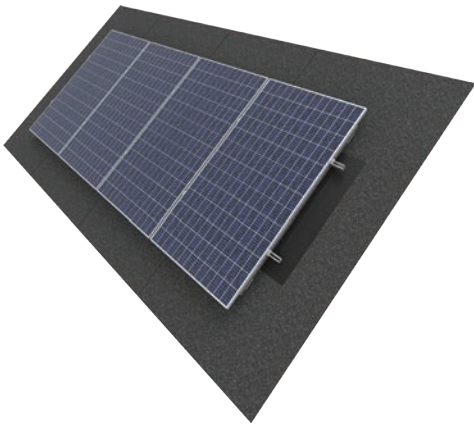

Structure description

A complete support system that allows the fixing of any number of PV panels in a vertical arrangement on a inclined roof covered with roofing felt and membrane.

Technical description:

Materials of the support system:

A- Aluminium

E- Stainless steel

MC- Coated structural steel:

Magnelis®, MagiZinc®, PosMAC

Structure tested for strength.

Advantages:

- quick installation and low price
- strength-tested construction
- made of sheet metal with coating: Magnelis®, MagiZinc®, PosMAC
- smooth adjustment of profile spacing
- no interference with roof sheathing
- very economical design with a small number of components
- very high corrosion resistance

Warranty

BAKS provides a 10 year warranty period for the components included in the support structure - only if all conditions of the manufacturer's warranty are met.

Arrangement of the modules:

· horizontal - H

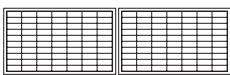

· vertical - V

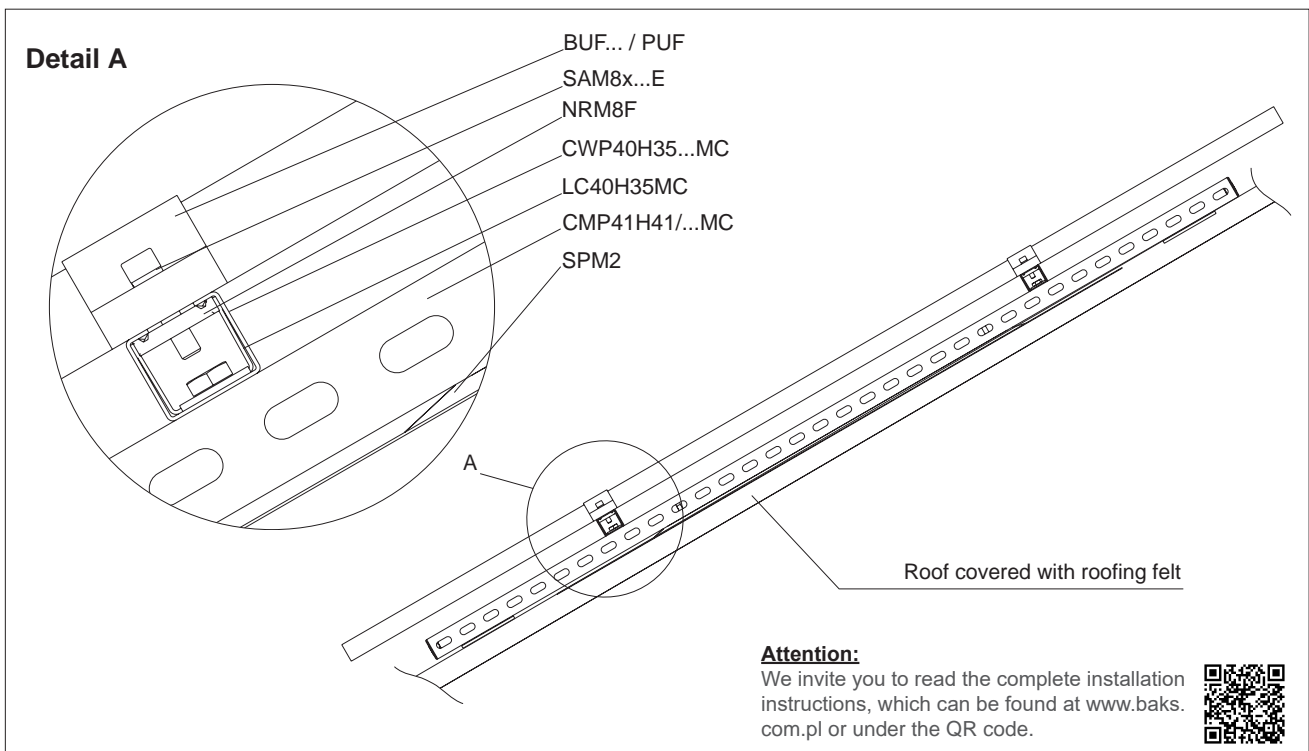
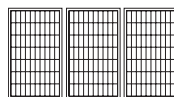

Detailed information on the products can be found on pages 80-174







**Mounting structures for the installation of photovoltaic panels
on flat roofs, in gardens, allotments, fields, on the ground and on paved
surfaces, building elevations and balcony railings**

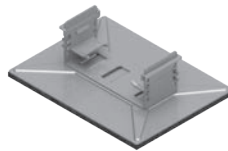
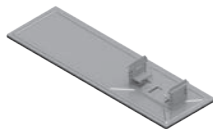
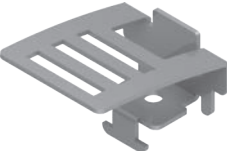

Structure systems for flat roofs, building elevations and balcony railings:

- flat roofs, system: **DP-DTHBSE, DP-DTHBSN, DP-DTHBSE-WZ, DP-DTHBSN-WZ**
- flat roofs, system: **DP-DNHBE, DP-DNHKE, DP-DNHWE, DP-DNHKSE**
- flat roofs, system: **DP-DNHBE-WZ, DP-DNHKE-WZ, DP-DNHWE-WZ, DP-DNHKSE-WZ**
- flat roofs, system: **DP-DTHBN, DP-DTHKN, DP-DTHWN, DP-DTHKSN**
- flat roofs, system: **DP-DTHBN-WZ, DP-DTHKN-WZ, DP-DTHWN-WZ, DP-DTHKSN-WZ**
- flat roofs, system: **DP-DTHBF, DP-DTHKF, DP-DTHWF, DP-DTHKSF**
- flat roofs, system: **DP-DTHBF-WZ, DP-DTHKF-WZ, DP-DTHWF-WZ, DP-DTHKSF-WZ**
- flat roofs, system: **DP-DTVKN, DP-DTVBN**
- flat roofs, system: **DP-DTAVKN, DP-DTAVBN**
- building elevations, system: **E-VKRN, E-VKTN, E-HKRN**
- balcony railings, system: **B-VPN, B-HPN, B-HKAN**













Examples of system components:

 <p>Top profile PGTSMC</p>	 <p>Bottom profile PDTSMC</p>	 <p>CLICK ballast base with height adjustment SKR95MC</p>	 <p>CLICK ballast base with height adjustment SKRB95MC</p>
 <p>Panel's Bottom Holder UPDMC</p>	 <p>Panel's Top Holder UPG...MC</p>	 <p>Steel Fixing Plate for Flat Roofs SPM1</p>	 <p>Universal wind shield OWN...NMC</p>

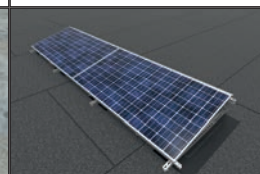
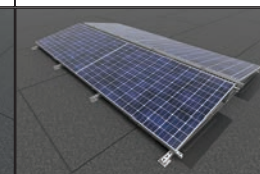
Advantages of the structures for mounting photovoltaic panels on flat roofs, building elevations and balcony railings

- structures available in steel in Magnelis® coating and aluminium
- universal structures for flat roofs that can be fixed directly to the roofing with: anchors, boards glued to the membrane or the roofing felt, or used as ballast structures
- variable adjustment and longitudinal perforation of the structure components allows for trouble-free and quick installation of the structure even in case of unevenness on the roof
- perforation in the wind shields allows for easy and quick installation even after the photovoltaic panels have been installed
- universal wind shields allow for quick installation and there is no need to order shields with dimensions dedicated to a given panel
- specially designed profile of the wind shields ensures stable adhesion to the structure, and after using additional pressure plates, even strong wind does not cause vibration
- the dimensions of the wind shields are adapted to various types of panels, thanks to which their installation does not require drilling
- triangular structures made of channels allow the panels to be mounted to steel profiles in the Magnelis® coating and to aluminium profiles
- PUFP, PUFEF, BUFP..., BUFEF... clamps with grounding washers, without damaging the panel frames
- products made in Poland!

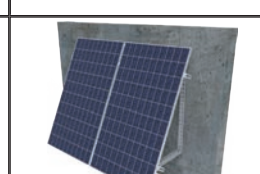
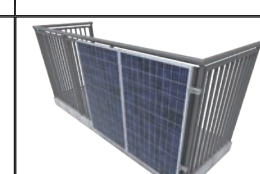
Systems:

				
DP-DTH...S	DP-DTH...S-WZ	DP-DTH...F	DP-DTH...F-WZ	DP-DNH...EL
				
DP-DNH...E	DP-DNH...E-WZ	DP-DTH...N	DP-DTH...N-WZ	DP-DTAV...N
				
DP-DTV...N	E-VKRN	E-VKTN	B-VPN	B-HKAN

Recommended ways of mounting flat structures

Structure mounting variants:

DP-DNHBE

Structure mounted on a flat roof without interference with the roofing by means of additional ballast such as e.g. concrete blocks. Steel elements of the structure are separated from the roofing by thick vibration damping rubber.

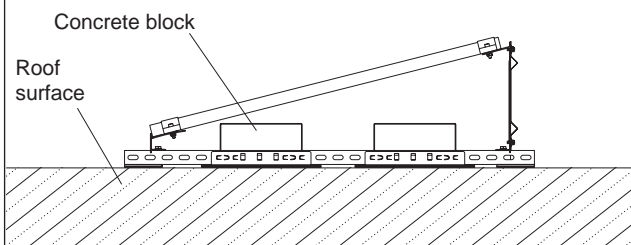

DP-DNHKE

Structure mounted on a flat roof using mechanical or chemical anchors. Used on flat roofs that allow interference. Can be used on roofs with low load-bearing capacity due to elimination of ballasting. Steel elements of the structure are separated from the roofing by thick vibration damping rubber.

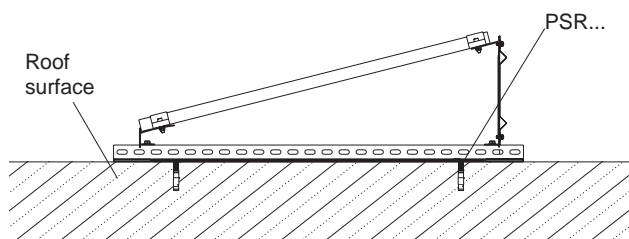

DP-DNHWE

The structure is mounted on a flat roof using innovative bases glued into the roofing made of bituminous felt or membrane. Thanks to the very high strength of glued-in bases, the structure does not require ballasting and anchoring, thanks to which it can be used on roofs with low bearing capacity without interference in the roofing.

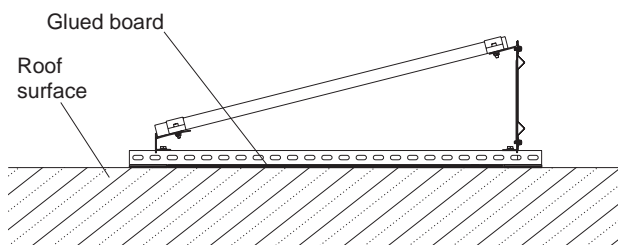

DP-DNHKSE

The structure is mounted on a flat roof covered with trapezoidal metal sheets or sandwich panels by means of long sections of aluminium mounting rails SM... Such a method of mounting facilitates the installation of the structure to the above mentioned roofings.

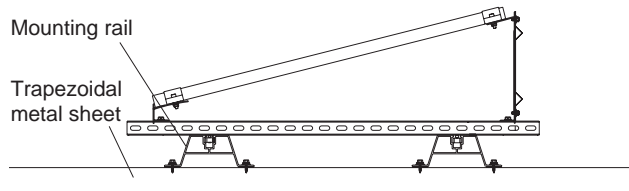

DP-DTHBSE

- variants of mounting the structure to the ground

1. On adjustable ballast feet
SKRB95 (concrete blocks)
- ballast method

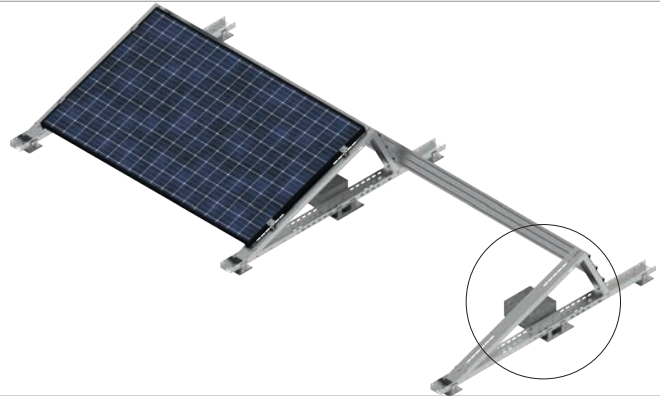
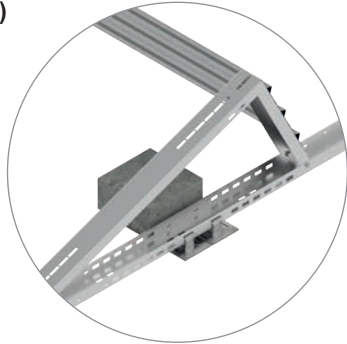

2. On a KF...MC sheet metal channel
(concrete blocks)
- ballast method

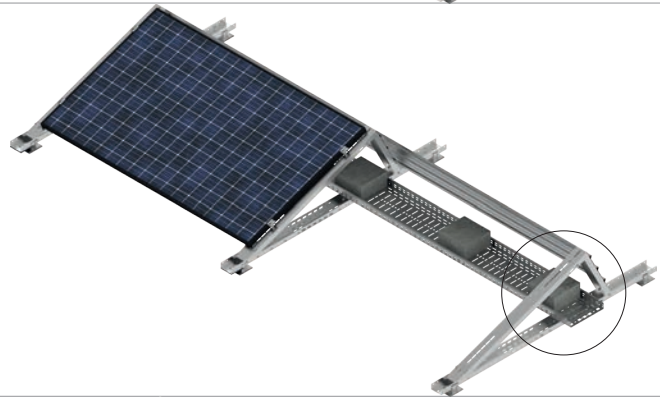

3. On the bottom profile
(paving stones)
- ballast method

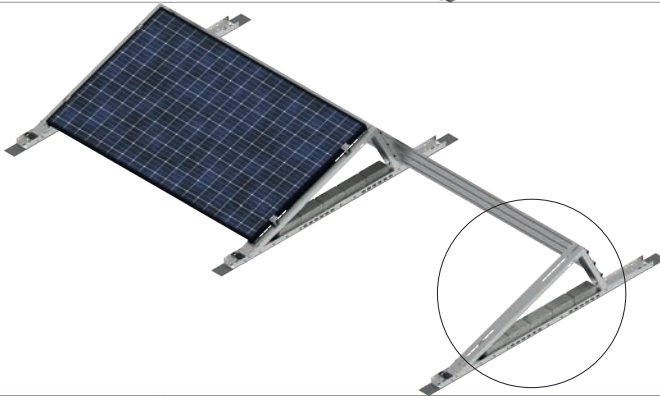

4. On the bottom profile
(concrete blocks)
- ballast method

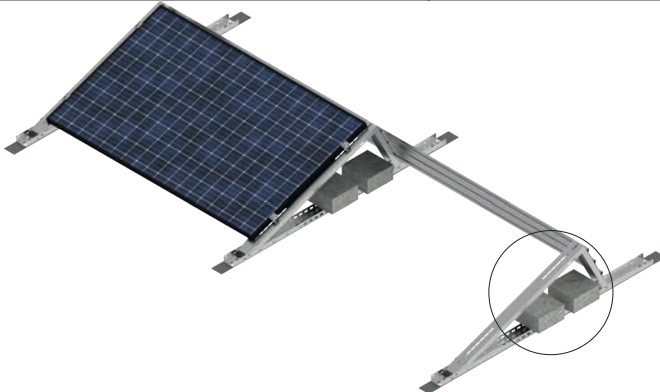
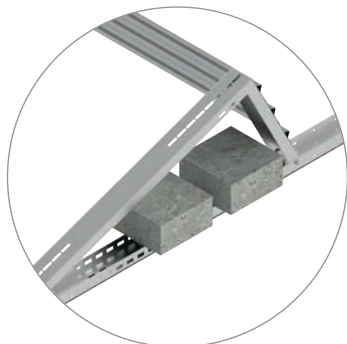

*the selection of ballast size should always be confirmed with the designer



Mounting structures for the installation of photovoltaic panels on flat roofs, in gardens, allotments, fields, on the ground and on paved surfaces

System: DP-DTHBSE (10°, 15°, 20°)

ST



Structure description

A complete support system that allows for horizontal mounting of panels at angles of 10, 15, and 20° on flat roofs. The DP-DTH...SE system allows for panel installation without disturbing the roof covering by loading the structure with concrete blocks. The design allows for the installation of photovoltaic panels on the short side (for panels up to 2100 mm long).

Technical description:

Materials of the support system:
MC- Coated structural steel:
 Magnelis®, MagiZinc®, PosMAC
A- Aluminium
E- Stainless steel
F- Steel in zinc flake coating
 Structure tested for strength.

Structure assembly variants:

- anchored to the roof - DP-DTHKSE
- ballast - DP-DTHBSE
- glued - DP-DTHWSE
- aluminum mounting rail - DP-DTHKSSE

Warranty

BAKS provides a 10 year warranty period for the components included in the support structure - only if all conditions of the manufacturer's warranty are met.

Advantages:

- structure tested for strength
- quick assembly due to the limited number of elements
- the ability to connect subsequent rows – in the case of a ballast structure, this significantly reduces the required ballast weight
- Panels can be attached without clamps using screws to dedicated holes or using clamps CLICK
- Specially designed teeth ensure electrical continuity between the structure and the panel frames
- 3 ballast placement options: paving stones placed in the lower channel sections, concrete blocks placed on adjustable snap-in ballast feet, concrete blocks placed in sheet metal troughs along the panels
- The design allows for the installation of panels up to 2100 mm long and 1150 mm wide
- 3-step panel angle adjustment with angle markings on the lower profile - 10°, 15°, 20°
- The aerodynamic shape of the structure with wind shields significantly reduces the required ballast weight.
- 3-step adjustment of the distance from the roof to the structure: 19, 26, and 33 mm using adjustable ballast bases

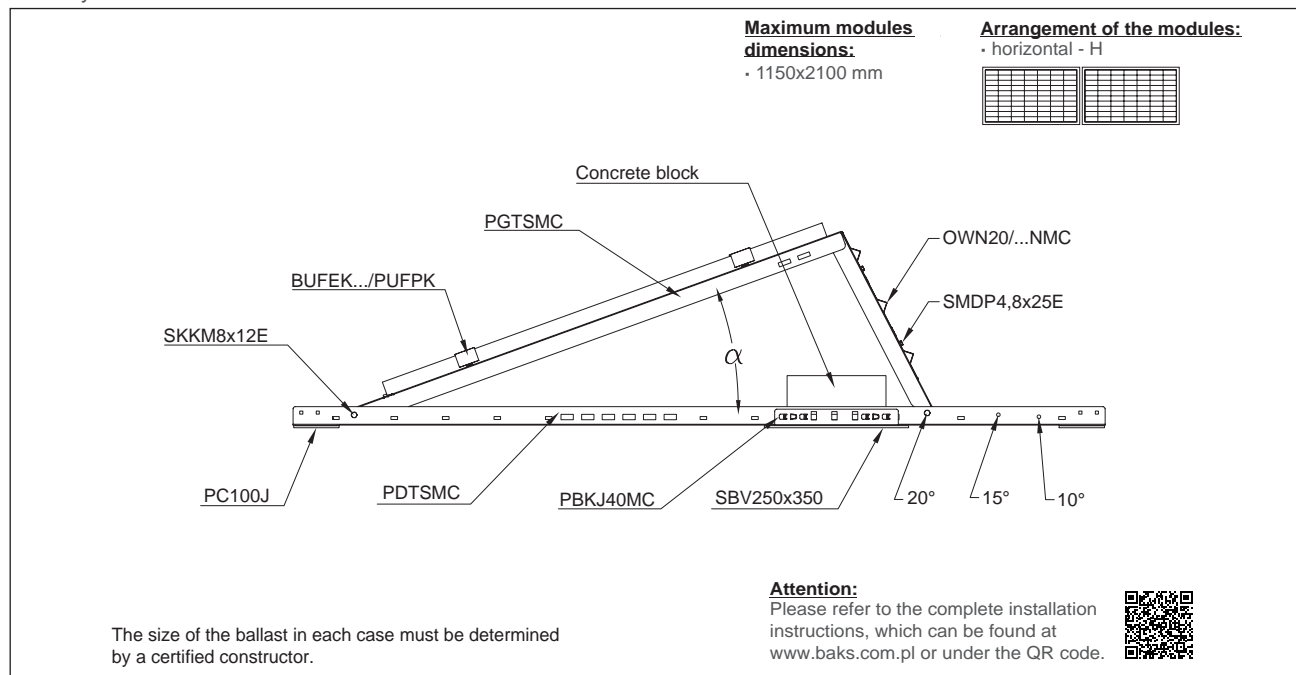

Detailed information on the products can be found on pages 80-174



Mounting structures for the installation of photovoltaic panels on flat roofs, in gardens, allotments, fields, on the ground and on paved surfaces

System: DP-DTHBSN (10°, 15°, 20°)

ST

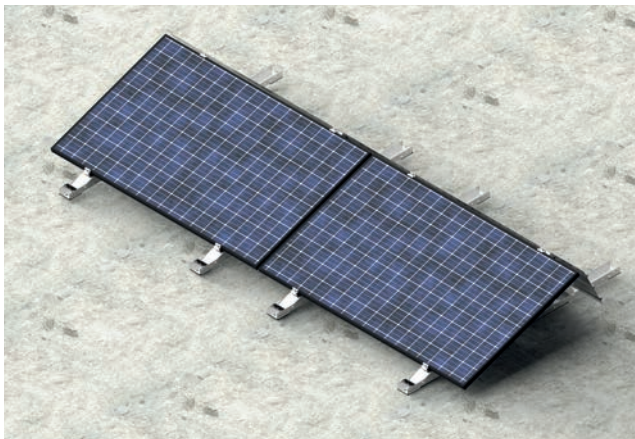

Structure description

A complete support system enabling horizontal mounting of panels at angles of 10, 15, and 20° on flat roofs. The DP-DTH...SN system allows for panel installation without disturbing the roof covering by loading the structure with concrete blocks. The design allows for mounting photovoltaic panels on the short side (for panels up to 2100 mm long) and on the long side.

Technical description:

Materials of the support system:
MC- Coated structural steel:
 Magnelis®, MagiZinc®, PosMAC
A- Aluminium
E- Stainless steel
F- Steel in zinc flake coating
 Structure tested for strength.

Structure assembly variants:

- anchored to the roof - DP-DTHKSN
- ballast - DP-DTHBSN
- glued - DP-DTHWSN
- aluminum mounting rail - DP-DTHKSSN

Warranty

BAKS provides a 10 year warranty period for the components included in the support structure - only if all conditions of the manufacturer's warranty are met.

Advantages:

- structure tested for strength
- quick assembly due to the limited number of elements
- the ability to connect subsequent rows – in the case of a ballast structure, this significantly reduces the required ballast weight
- Panels can be attached without clamps using screws to dedicated holes or using clamps CLICK
- Specially designed teeth ensure electrical continuity between the structure and the panel frames
- 3 ballast placement options: paving stones placed in the lower channel sections, concrete blocks placed on adjustable snap-in ballast feet, concrete blocks placed in sheet metal troughs along the panels
- The design allows for the installation of panels up to 2400 mm long and 1150 mm wide.
- 3-step panel angle adjustment with angle markings on the lower profile - 10°, 15°, 20°
- The aerodynamic shape of the structure with wind shields significantly reduces the required ballast weight.
- 3-step adjustment of the distance from the roof to the structure: 19, 26, and 33 mm using adjustable SKRB ballast bases...

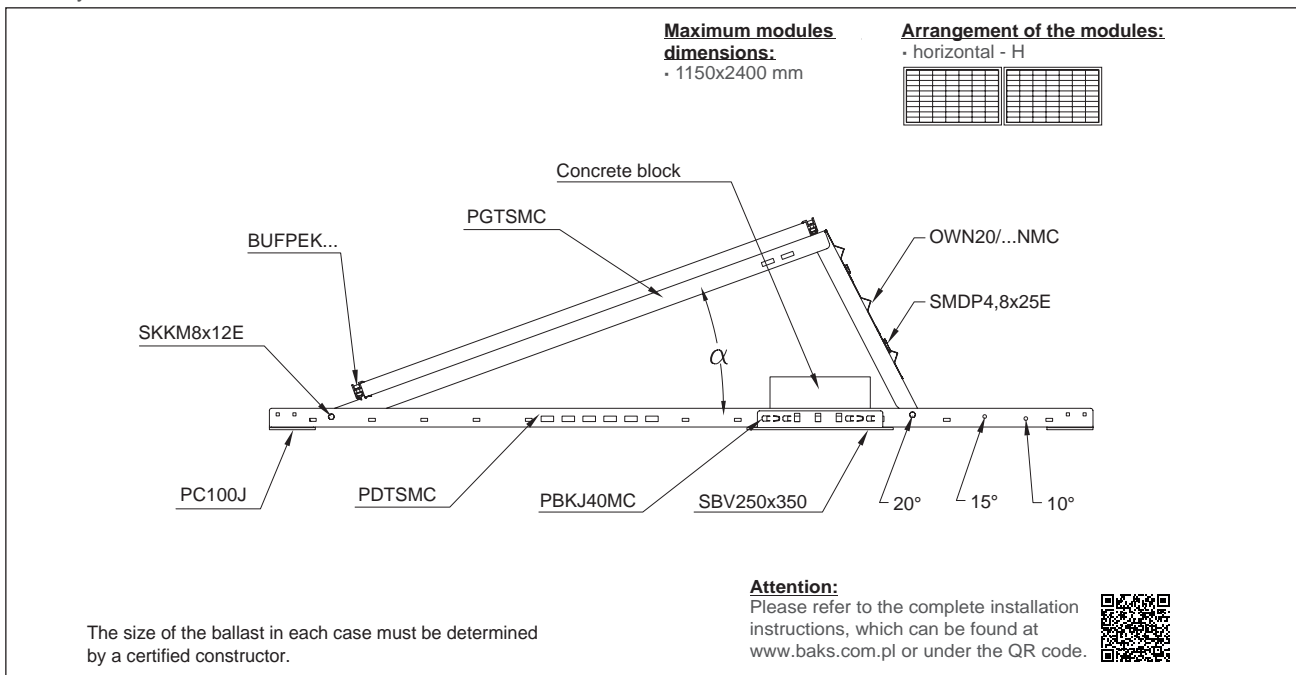

Detailed information on the products can be found on pages 80-174



Mounting structures for the installation of photovoltaic panels on flat roofs, in gardens, allotments, fields, on the ground and on paved surfaces

System: DP-DTHBSE-WZ (10°, 15°)

ST



Structure description

A complete support system that allows for horizontal mounting of panels at angles of 10 and 15° on a flat roof. The DP-DTH...SE-WZ system allows for panel installation without disturbing the roof covering by loading the structure with concrete blocks. The design allows for the installation of photovoltaic panels on the short side (for panels up to 2100 mm long).

Technical description:

Materials of the support system:

- MC- Coated structural steel:
 - Magnelis®, MagiZinc®, PosMAC
 - A- Aluminium
 - E- Stainless steel
 - F- Steel in zinc flake coating
- Structure tested for strength.

Structure assembly variants:

- anchored to the roof - DP-DTHKSE-WZ
- ballast - DP-DTHBSE-WZ
- glued - DP-DTHWSE-WZ
- aluminum mounting rail - DP-DTHKSSE-WZ

Warranty

BAKS provides a 10 year warranty period for the components included in the support structure - only if all conditions of the manufacturer's warranty are met.

Advantages:

- structure tested for strength
 - quick assembly due to the limited number of elements
 - the ability to connect subsequent rows – in the case of a ballast structure, this significantly reduces the required ballast weight
 - Panels can be attached without clamps using screws to dedicated holes or using clamps CLICK
 - Specially designed teeth ensure electrical continuity between the structure and the panel frames
 - 3 ballast placement options: paving stones placed in the lower channel sections, concrete blocks placed on adjustable snap-in ballast feet, concrete blocks placed in sheet metal troughs along the panels
 - The design allows for the installation of panels up to 2100 mm long and 1150 mm wide.
 - 2-step panel angle adjustment with angle markings on the lower profile - 10°, 15°
 - The aerodynamic shape of the structure with wind shields significantly reduces the required ballast weight.
- 3-step adjustment of the distance from the roof to the structure: 19, 26, and 33 mm using adjustable SKRB ballast bases...

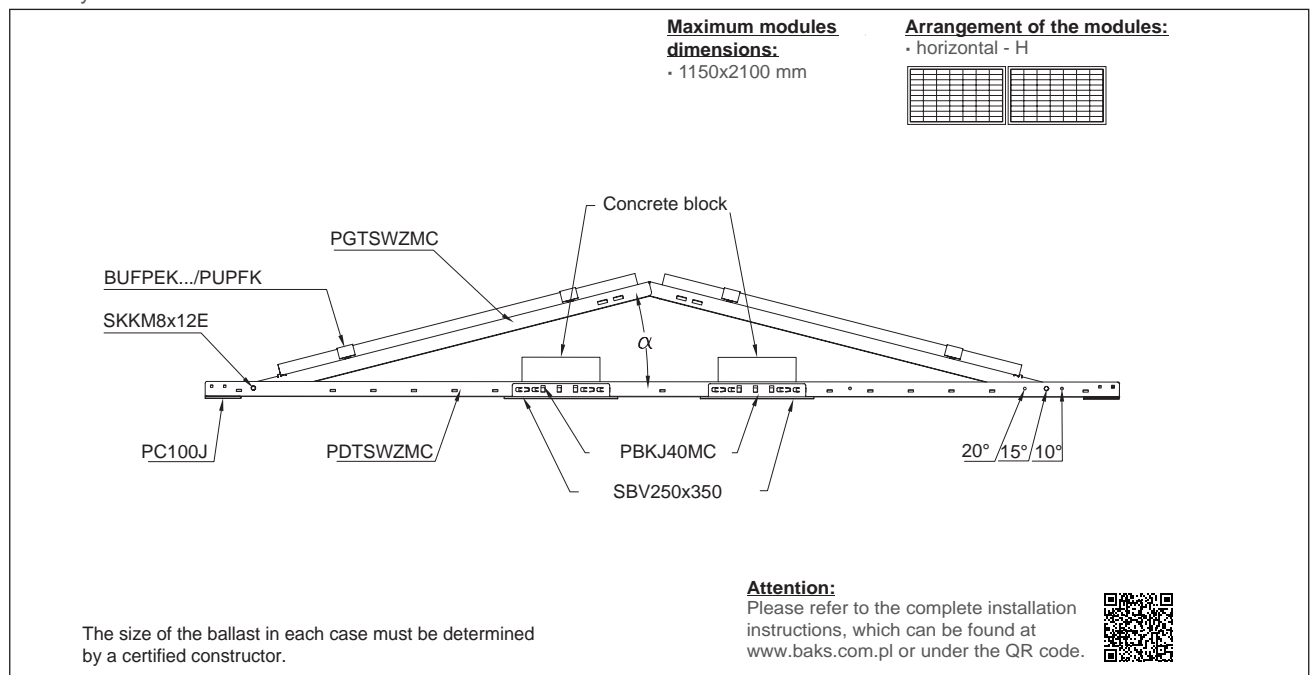

Detailed information on the products can be found on pages 80-174



Mounting structures for the installation of photovoltaic panels on flat roofs, in gardens, allotments, fields, on the ground and on paved surfaces

System: DP-DTHBSN-WZ (10°, 15°)

ST



Structure description

A complete support system that allows for horizontal mounting of panels at angles of 10 and 15° on a flat roof. The DP-DTH...SN-WZ system allows for panel installation without disturbing the roof covering by loading the structure with concrete blocks. The design allows for mounting photovoltaic panels on the short side (for panels up to 2100 mm long) and on the long side.

Technical description:

Materials of the support system:

- MC- Coated structural steel:
 - Magnelis®, MagiZinc®, PosMAC
 - A- Aluminium
 - E- Stainless steel
 - F- Steel in zinc flake coating
- Structure tested for strength.

Structure assembly variants:

- anchored to the roof - DP-DTHKSN-WZ
- ballast - DP-DTHBSN-WZ
- glued - DP-DTHWSN-WZ
- aluminum mounting rail - DP-DTHKSSN-WZ

Warranty

BAKS provides a 10 year warranty period for the components included in the support structure - only if all conditions of the manufacturer's warranty are met.

Advantages:

- structure tested for strength
- quick assembly due to the limited number of elements
- the ability to connect subsequent rows – in the case of a ballast structure, this significantly reduces the required ballast weight
- Panels can be attached without clamps using screws to dedicated holes or using clamps CLICK
- Specially designed teeth ensure electrical continuity between the structure and the panel frames
- 3 ballast placement options: paving stones placed in the lower channel sections, concrete blocks placed on adjustable snap-in ballast feet, concrete blocks placed in sheet metal troughs along the panels
- The design allows for the installation of panels up to 2500 mm long and 1150 mm wide.
- 2-step panel angle adjustment with angle markings on the lower profile - 10°, 15°
- The aerodynamic shape of the structure with wind shields significantly reduces the required ballast weight.
- 3-step adjustment of the distance from the roof to the structure: 19, 26, and 33 mm using adjustable SKRB ballast bases...

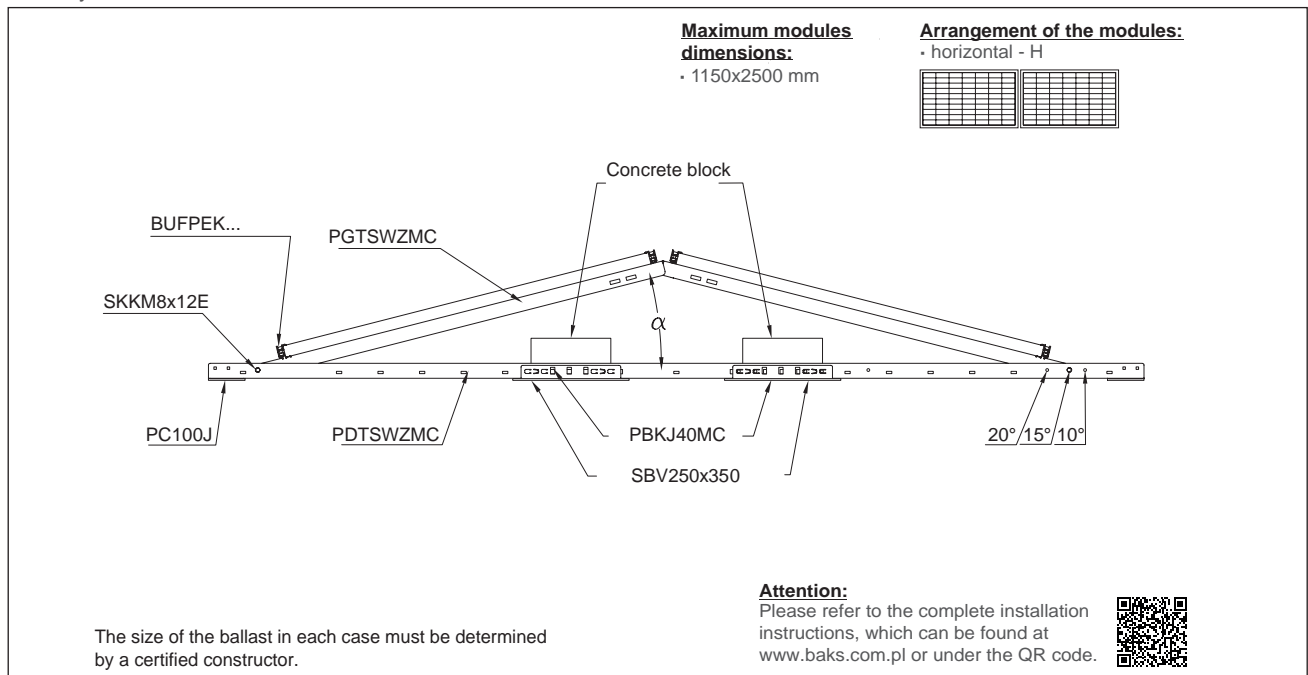



Mounting structures for the installation of photovoltaic panels on flat roofs, in gardens, allotments, fields, on the ground and on paved surfaces

System: DP-DNHBE (10°, 15°, 20°)

ST

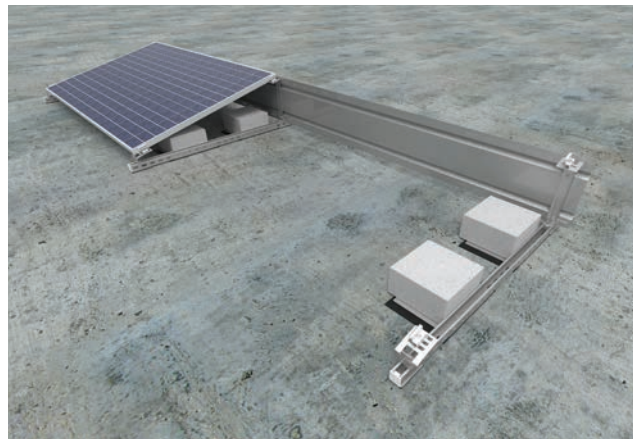
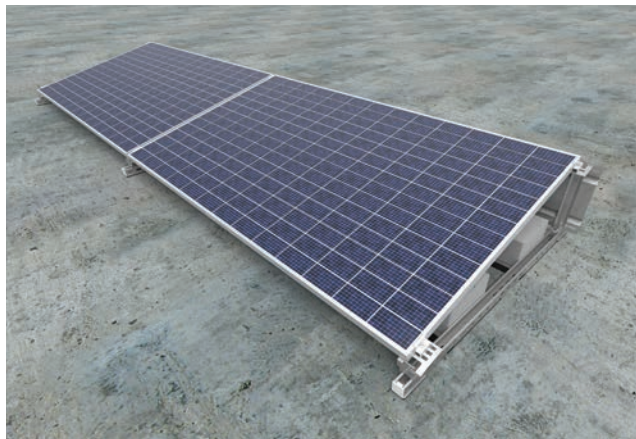

Structure description

Complete support system for fixing the panels horizontally at angles of 10°, 15° and 20° on a flat roof. The DP-DNHBE system enables the panels to be installed without disturbing the roofing thanks to the ballasting of the structure with concrete blocks (protect the blocks from soaking in rainwater).

Technical description:

Materials of the support system:

MC- Coated structural steel:

Magnelis®, MagiZinc®, PosMAC

A- Aluminium

E- Stainless steel

F- Steel in zinc flake coating

Structure tested for strength.

Structure assembly variants:

- anchored to the roof
- ballast
(after using vibration damping pads and ballast bases)
- glued
- aluminum mounting rail

Advantages:

- quick installation and low price,
- structure tested for strength
- steel in Magnelis® coating guarantees very high corrosion resistance
- top brackets equipped with threaded holes for easy installation of windshields
- variable adjustment of the spacing of holders in the main profile
- longitudinal holes for panel mounting in the UPDMC and UPG... MC holders extend the tolerances for mounting of the panels to the structure mounted on the roof
- bottom holder for setting three angles: 10°, 15° and 20°
- clamps with integrated grounding pads

Warranty

BAKS provides a 10 year warranty period for the components included in the support structure - only if all conditions of the manufacturer's warranty are met.

The table below allows you to select a set of holders (bottom + top) in order to obtain a structure with an appropriate angle of inclination of the panels.

inclination angle of the panels	panel's bottom holder	panel's top holder
10°	UPDMC	UPG10MC
15°	UPDMC	UPG15MC
20°	UPDMC	UPG20MC

Maximum modules dimensions:

• 1150x2100 mm

Arrangement of the modules:

- horizontal - H

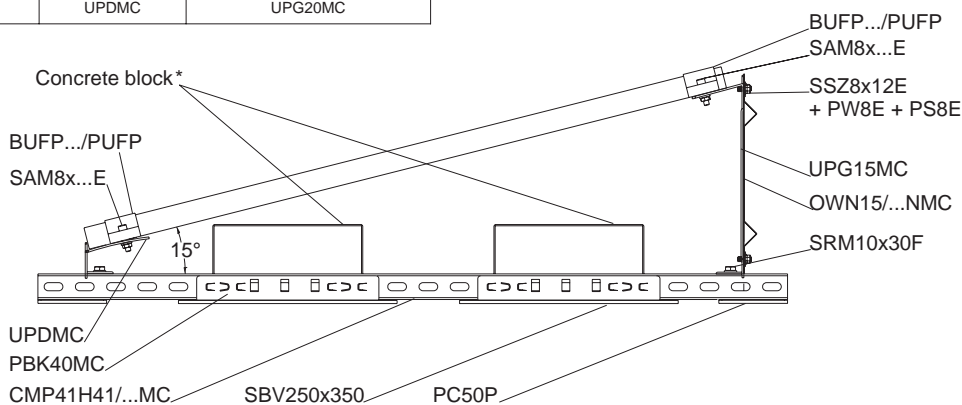
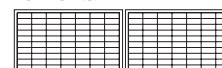

Attention:

Please refer to the complete installation instructions, which can be found at www.baks.com.pl or under the QR code.





Mounting structures for the installation of photovoltaic panels on flat roofs, in gardens, allotments, fields, on the ground and on paved surfaces System: DP-DNHBEL (10°, 15°, 20°)

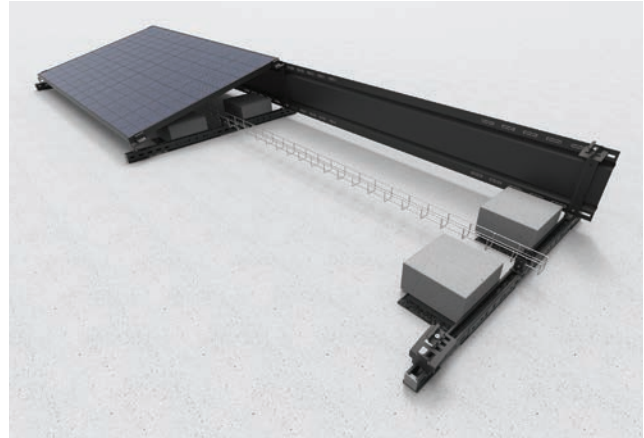
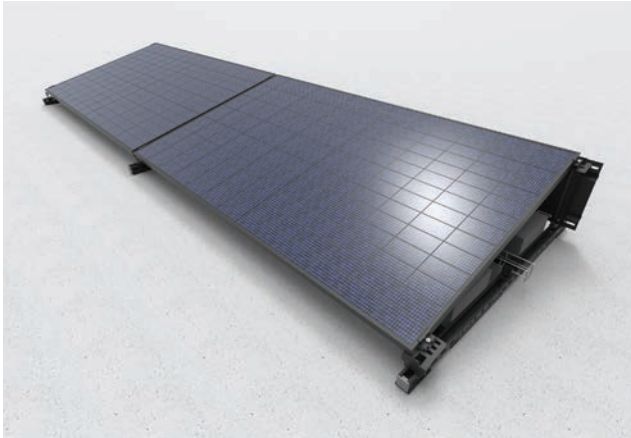

Structure description

Complete support system for fixing the panels horizontally at angles of 10°, 15° and 20° on a flat roof. The DP-DNHBEL system enables the panels to be installed without disturbing the roofing thanks to the ballasting of the structure with concrete blocks (protect the blocks from soaking in rainwater).

Technical description:

Materials of the support system:

MC- Coated structural steel:

Magnelis®, MagiZinc®, PosMAC (structure elements)

L- painting in black RAL9005 colour

A- Aluminium

E- Stainless steel

F- Steel in zinc flake coating

(screws for screwing the structure)

Structure tested for strength.

Structure assembly variants:

- anchored to the roof
- ballast (after using vibration damping pads and ballast bases)
- glued
- aluminum mounting rail

Advantages:

- quick installation and low price,
- structure tested for strength
- steel in Magnelis® coating guarantees very high corrosion resistance
- top brackets equipped with threaded holes for easy installation of windshields
- variable adjustment of the spacing of holders in the main profile
- longitudinal holes for panel mounting in the UPDMC and UPG... MC holders extend the tolerances for mounting of the panels to the structure mounted on the roof
- bottom holder for setting three angles: 10°, 15° and 20°
- Maintained electrical continuity between panels and structural elements
- The use of a varnished coating (in black RAL9005) improves the aesthetics of the structure when black panel frames are used
- clamps with integrated grounding pads

Warranty

BAKS provides a 10 year warranty period for the components included in the support structure - only if all conditions of the manufacturer's warranty are met.

The table below allows you to select a set of holders (bottom + top) in order to obtain a structure with an appropriate angle of inclination of the panels.

inclination angle of the panels	panel's bottom holder	panel's top holder
10°	UPDMC	UPG10MC
15°	UPDMC	UPG15MC
20°	UPDMC	UPG20MC

Maximum modules dimensions:

• 1150x2100 mm

Arrangement of the modules:

• horizontal - H

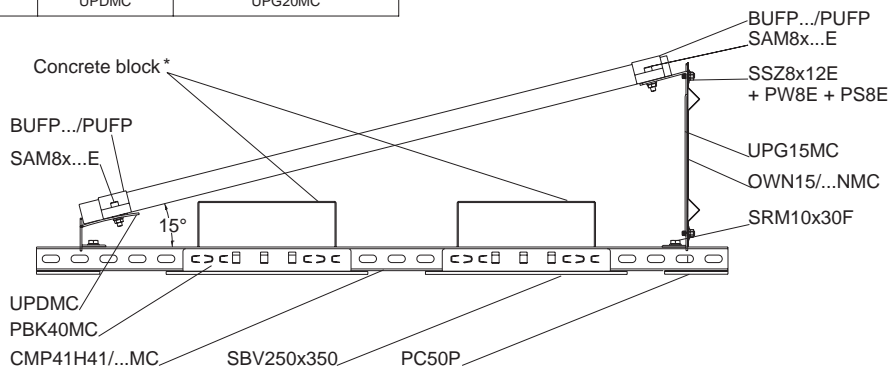
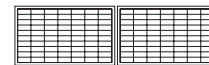

The ballast value can be as high as about 100kg/panel. The size of the ballast in each case must be determined by a certified constructor.

Attention:

Please refer to the complete installation instructions, which can be found at www.baks.com.pl or under the QR code.





Mounting structures for the installation of photovoltaic panels on flat roofs covered with roofing felt
System: DP-DNHWE (10°, 15°, 20°) (glued)

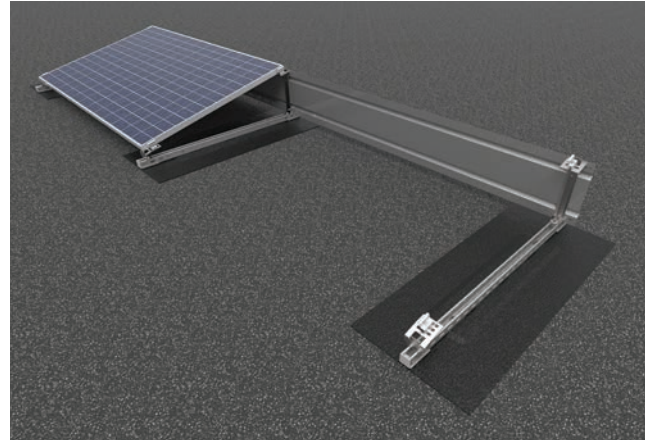
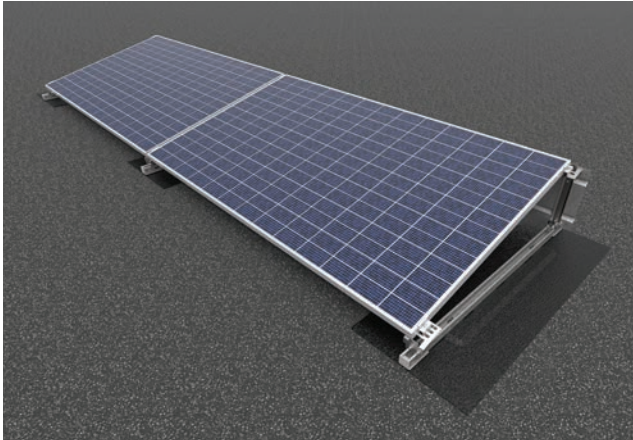

Structure description

Complete support system for fixing the panels horizontally at angles of 10°, 15° and 20° on a flat roof covered with roofing felt or membrane without disturbing the roofing or using additional ballasting.

Technical description:

Materials of the support system:

MC- Coated structural steel: Magnelis®, MagiZinc®, PosMAC

A- Aluminium

E- Stainless steel

F- Steel in zinc flake coating

Structure tested for strength.

Structure assembly variants:

- glued
- anchored to the roof
- ballast
(after using vibration damping pads and ballast bases)
- aluminum mounting rail

Advantages:

- quick installation and low price,
- structure tested for strength
- steel in Magnelis® coating guarantees very high corrosion resistance
- fixing the panel holders to the main profile with one screw and channel nut
- variable adjustment of the spacing of holders in the main profile
- longitudinal holes for panel mounting in the UPDMC and UPG...MC holders extend the tolerances for mounting of the panels to the structure mounted on the roof
- bottom holder for setting three angles: 10°, 15° and 20°
- no interference with roofing
- thanks to the use of SPM... eliminated additional load on the roof in the form of ballast
- clamps with integrated grounding pads

Warranty

BAKS provides a 10 year warranty period for the components included in the support structure - only if all conditions of the manufacturer's warranty are met.

The table below allows you to select a set of holders (bottom + top) in order to obtain a structure with an appropriate angle of inclination of the panels.

inclination angle of the panels	panel's bottom holder	panel's top holder
10°	UPDMC	UPG10MC
15°	UPDMC	UPG15MC
20°	UPDMC	UPG20MC

Maximum modules dimensions:
 • 1150x2100 mm

Arrangement of the modules:
 • horizontal - H

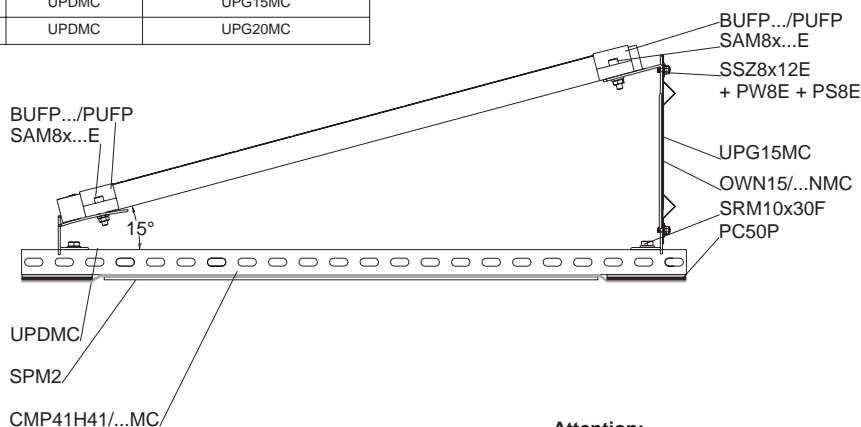
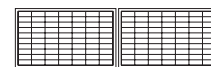

Attention:

Please refer to the complete installation instructions, which can be found at www.baks.com.pl or under the QR code.





Mounting structures for the installation of photovoltaic panels on flat roofs, in gardens, allotments, fields, on the ground and on paved surfaces

System: DP-DNHBE-WZ (east-west) (10°, 15°, 20°)

ST

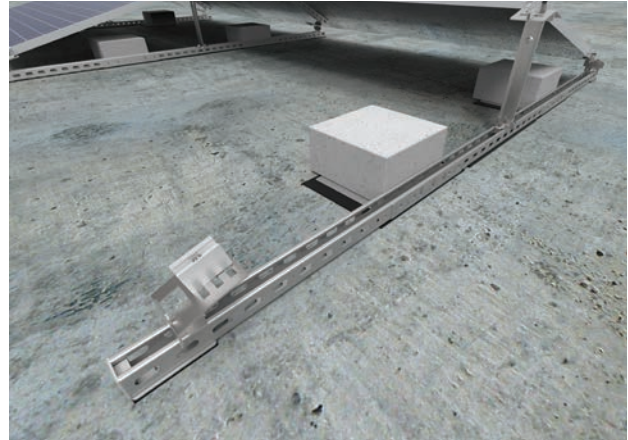
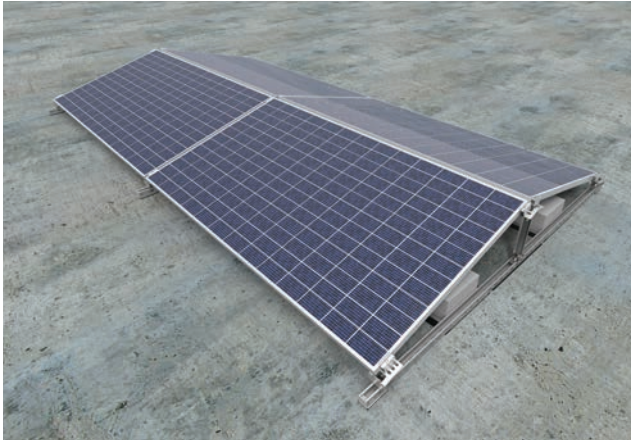

Structure description

Complete support system for fixing the panels horizontally at angles of 10°, 15° and 20° on a flat roof. The **DP-DNHBE (W-Z)** system enables the panels to be installed without disturbing the roofing thanks to the ballasting of the structure with concrete blocks (protect the blocks from soaking in rainwater)

Technical description:

Materials of the support system:

- MC- Coated structural steel: Magnelis®, MagiZinc®, PosMAC
 - A- Aluminium
 - E- Stainless steel
 - F- Steel in zinc flake coating
- Structure tested for strength.

Structure assembly variants:

- anchored to the roof
- ballast (after using vibration damping pads and ballast bases)
- glued
- aluminum mounting rail

Advantages:

- quick installation and low price
- structure tested for strength
- steel in Magnelis® coating guarantees very high corrosion resistance
- fixing the panel holders to the main profile with one screw and channel nut
- variable adjustment of the spacing of holders in the main profile
- longitudinal holes for panel mounting in the UPDMC and UPG...MC holders extend the tolerances for mounting of the panels to the structure mounted on the roof
- bottom holder for setting three angles: 10°, 15° and 20°
- the aerodynamic solution significantly reduces ballast, enabling installation on buildings with low roof load-bearing capacity
- clamps with integrated grounding pads

Warranty

BAKS provides a 10 year warranty period for the components included in the support structure - only if all conditions of the manufacturer's warranty are met.

The table below allows you to select a set of holders (bottom + top) in order to obtain a structure with an appropriate angle of inclination of the panels.

inclination angle of the panels	panel's bottom holder	panel's top holder
10°	UPDMC	UPG10MC
15°	UPDMC	UPG15MC
20°	UPDMC	UPG20MC

Maximum modules dimensions:

• 1150x2100 mm

Arrangement of the modules:

• horizontal - H

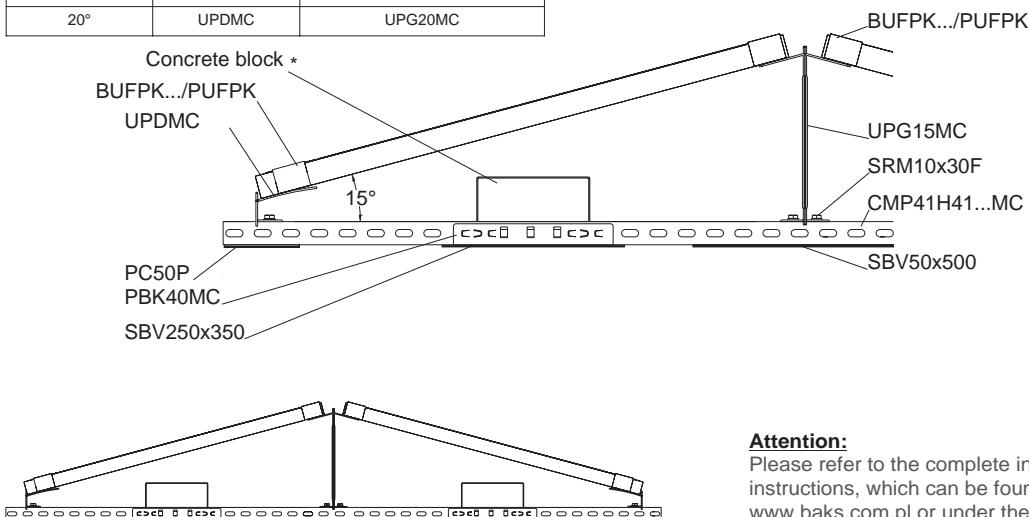
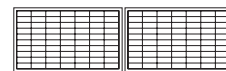

Attention:

Please refer to the complete installation instructions, which can be found at www.baks.com.pl or under the QR code.





Mounting structures for the installation of photovoltaic panels on flat roofs covered with roofing felt
System: DP-DTHWN (10°, 15°, 20°) (glued)

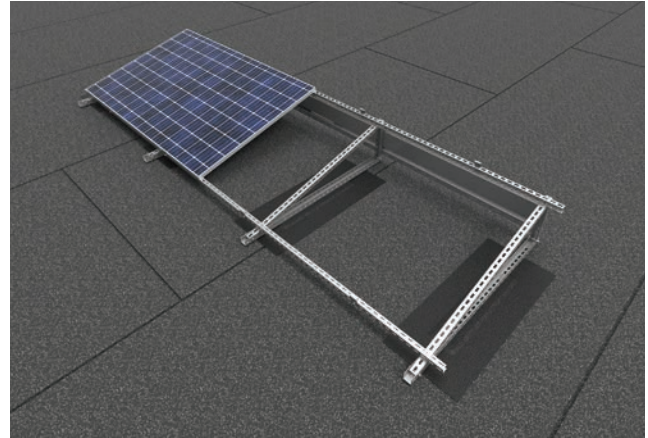
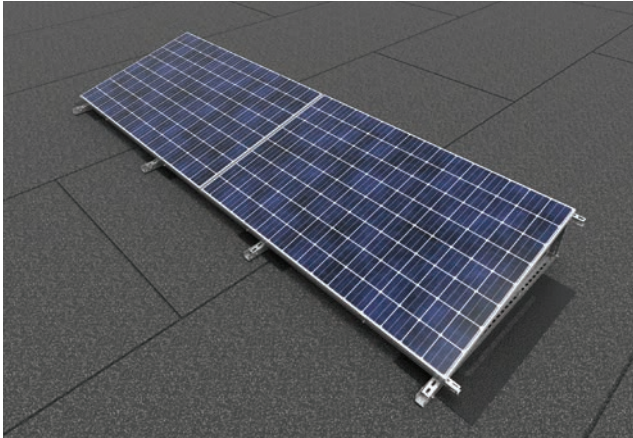

Structure description

Complete support system for fixing the panels horizontally at angles of 10°, 15° and 20° on a flat roof covered with roofing felt or membrane without disturbing the roofing or using additional ballasting.

Technical description:

Materials of the support system:

- MC- Coated structural steel: Magnelis®, MagiZinc®, PosMAC
 - A- Aluminium
 - E- Stainless steel
 - F- Steel in zinc flake coating
- Structure tested for strength.

Structure assembly variants:

- glued
 - anchored to the roof
 - ballast
- (after using vibration damping pads and ballast bases)
- aluminum mounting rail

Advantages:

- structure tested for strength
- steel in Magnelis® coating guarantees very high corrosion resistance
- possibility to install panels of any length
- no interference with roofing
- thanks to the use of SPM... eliminated additional load on the roof in the form of ballast
- universal mounting clamps with a mounting range of 30-40 mm
- clamps with integrated grounding pads
- design allows for the installation of panels of any length and width up to 1350 mm

Warranty

BAKS provides a 10 year warranty period for the components included in the support structure - only if all conditions of the manufacturer's warranty are met.

Arrangement of the modules:

- horizontal - H

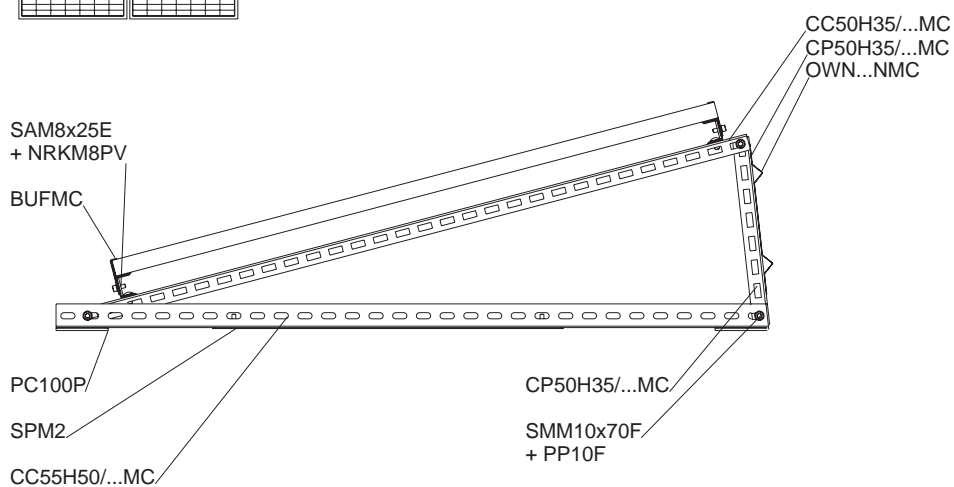

Attention:

Please refer to the complete installation instructions, which can be found at www.baks.com.pl or under the QR code.





Mounting structures for the installation of photovoltaic panels on flat roofs covered with roofing felt

System: DP-DTHWN-WZ (10°, 15°, 20°) (glued)

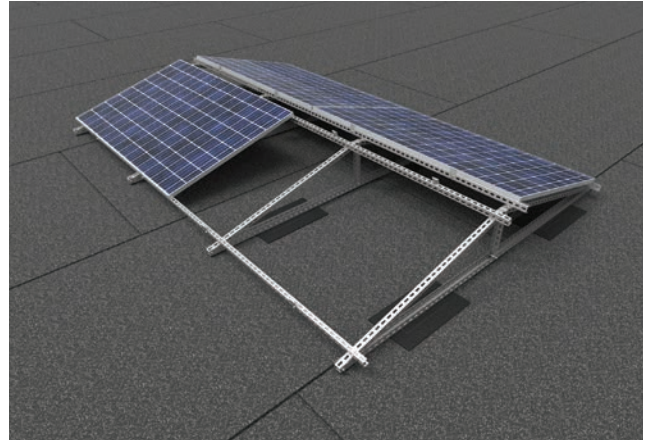
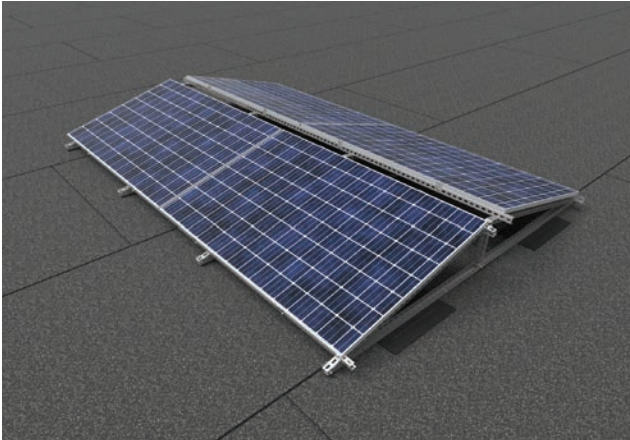

Structure description

Complete support system for fixing the panels horizontally at angles of 10°, 15° and 20° on a flat roof covered with roofing felt or membrane without disturbing the roofing or using additional ballasting.

Technical description:

Materials of the support system:
MC- Coated structural steel:
 Magnelis®, MagiZinc®, PosMAC
A- Aluminium
E- Stainless steel
F- Steel in zinc flake coating
 Structure tested for strength.

Structure assembly variants:

- anchored to the roof
- ballast
(after using vibration damping pads and ballast bases)
- glued
- aluminum mounting rail

Advantages:

- limited number of components and torsion points due to the use of a mounting base at the top of the central vertical channel
- structure tested for strength
- steel in Magnelis® coating guarantees very high corrosion resistance
- possibility to install panels of any length
- no interference with roofing
- thanks to the use of SPM... eliminated additional load on the roof in the form of ballast
- design allows for the installation of panels of any length and width up to 1350 mm

Warranty

BAKS provides a 10 year warranty period for the components included in the support structure - only if all conditions of the manufacturer's warranty are met.

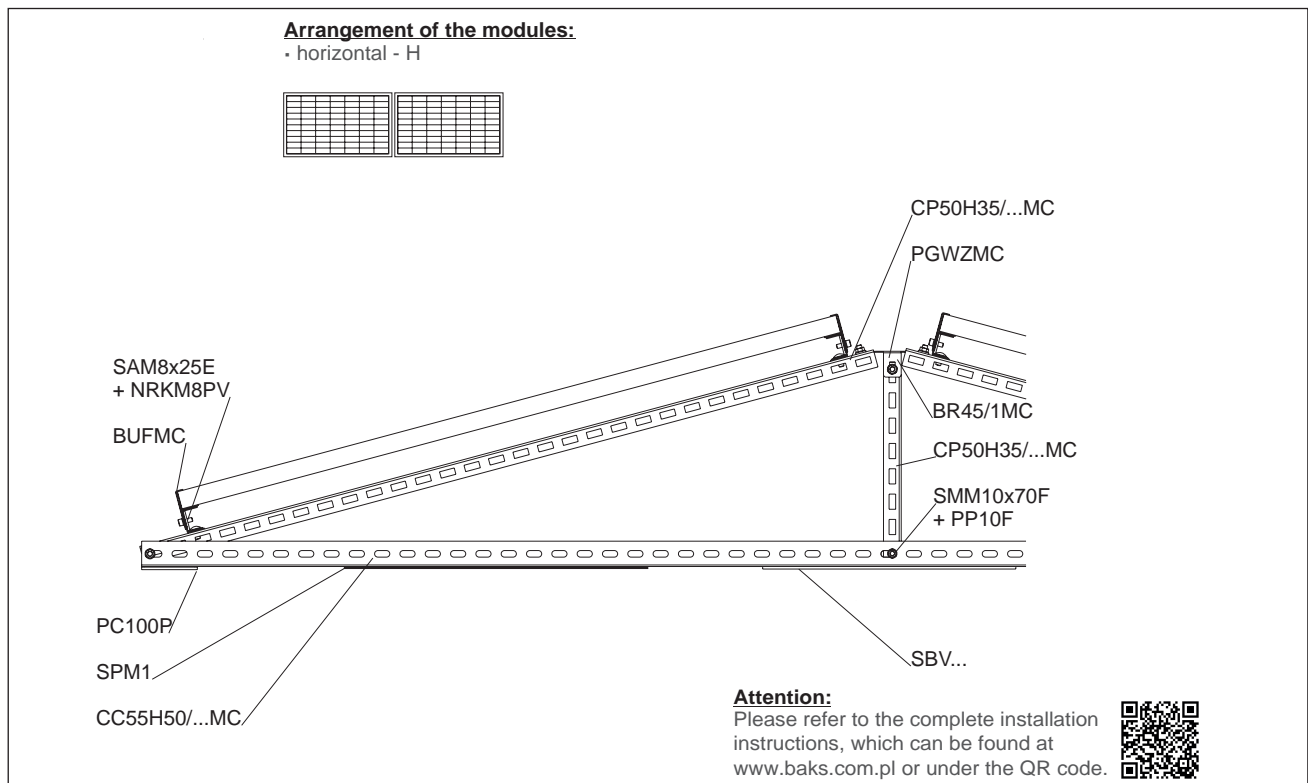

Detailed information on the products can be found on pages 80-174



Mounting structures for the installation of photovoltaic panels: on flat roofs, in gardens, allotments, fields, on the ground and on paved surfaces
System: DP-DTVKN (25°, 30°, 35°)

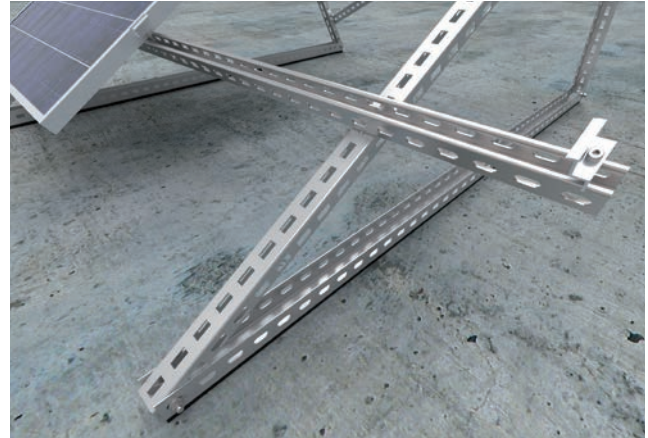
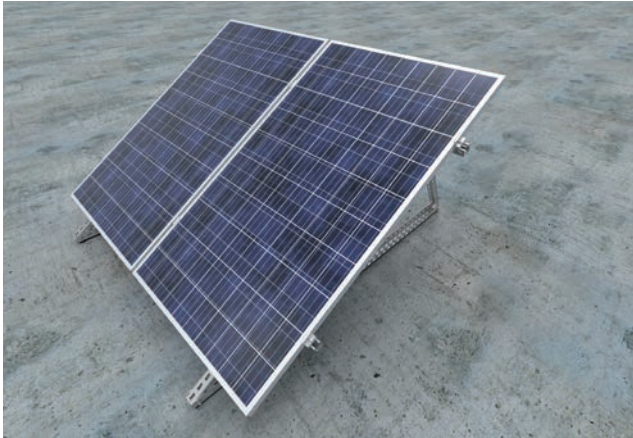

Structure description

Complete support system for fixing the panels vertically at angles of 25°, 30° and 35° on a flat roof. Anchored structure.

Technical description:

Materials of the support system:

- MC- Coated structural steel: Magnelis®, MagiZinc®, PosMAC
 - A- Aluminium
 - E- Stainless steel
 - F- Steel in zinc flake coating
- Structure tested for strength.

Structure assembly variants:

- anchored to the roof
- ballast
(after using vibration damping pads and ballast bases)

Advantages:

- quick installation
- low price
- structure tested for strength
- high stability of the structure
- steel in Magnelis® coating guarantees very high corrosion resistance
- possibility of fixing the panels on aluminium and steel profiles in Magnelis® coating
- possibility of setting three angles: 25°, 30° and 35°
- clamps with integrated grounding pads

Warranty

BAKS provides a 10 year warranty period for the components included in the support structure - only if all conditions of the manufacturer's warranty are met.

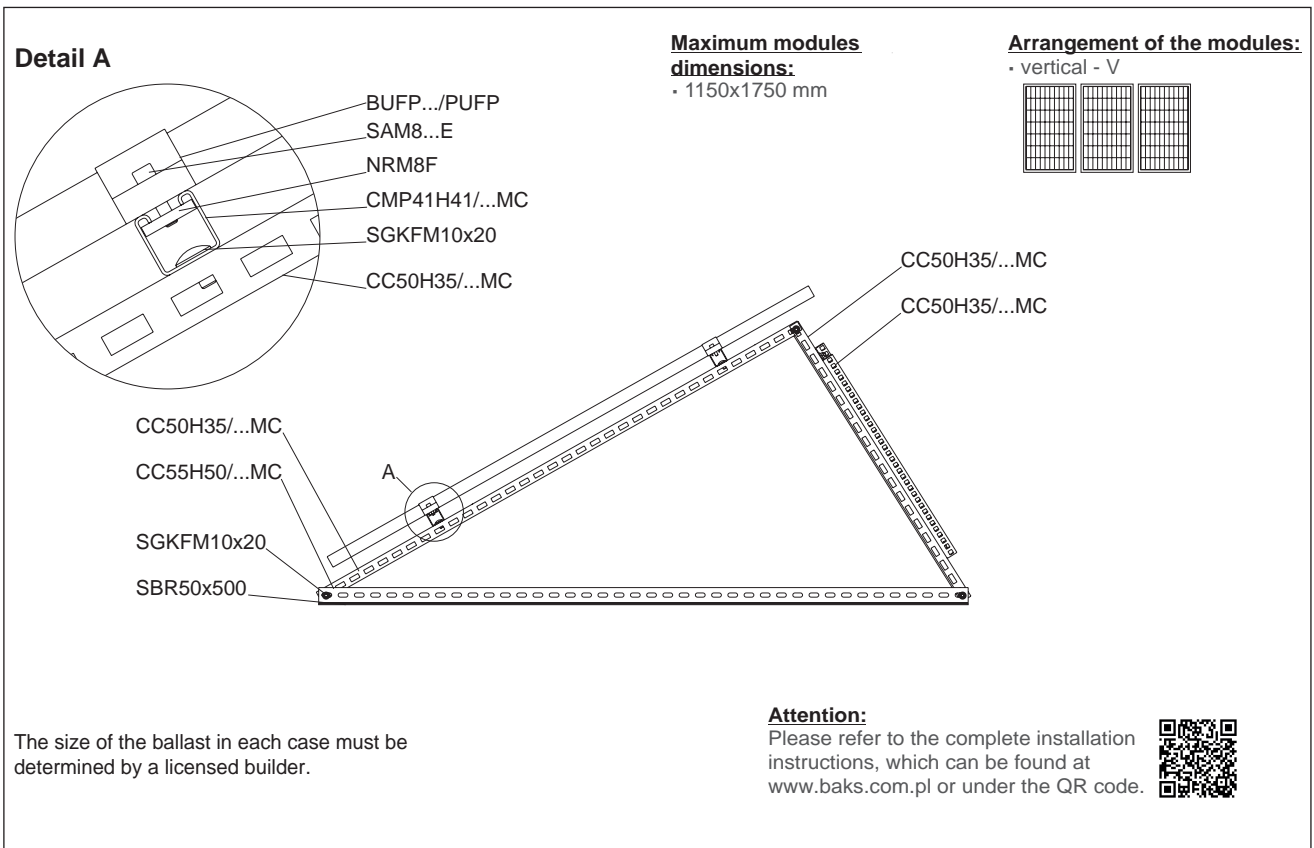



Mounting structures for the installation of photovoltaic panels: on flat roofs, in gardens, allotments, fields, on the ground and on paved surfaces

System: DP-DTAVKN (25°, 30°, 35°)

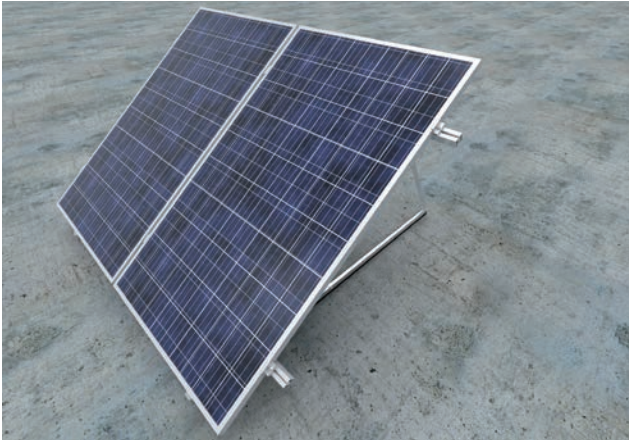

Structure description

Complete support system for fixing the panels vertically at angles of 25°, 30° and 35° on a flat roof. Anchored structure.

Technical description:

Materials of the support system:

A- Aluminium

E- Stainless steel

F- Steel in zinc flake coating

Structure tested for strength.

Structure assembly variants:

- anchored to the roof
- ballast
(after using vibration damping pads and ballast bases)

Advantages:

- quick installation
- low price
- structure tested for strength
- high stability of the structure
- aluminium guarantees very high corrosion resistance and lowers the weight of the support structure
- possibility of setting three angles: 25°, 30° and 35°
- lightweight structures, dedicated to roofs with low load capacity
- clamps with integrated grounding pads

Warranty

BAKS provides a 10 year warranty period for the components included in the support structure - only if all conditions of the manufacturer's warranty are met.

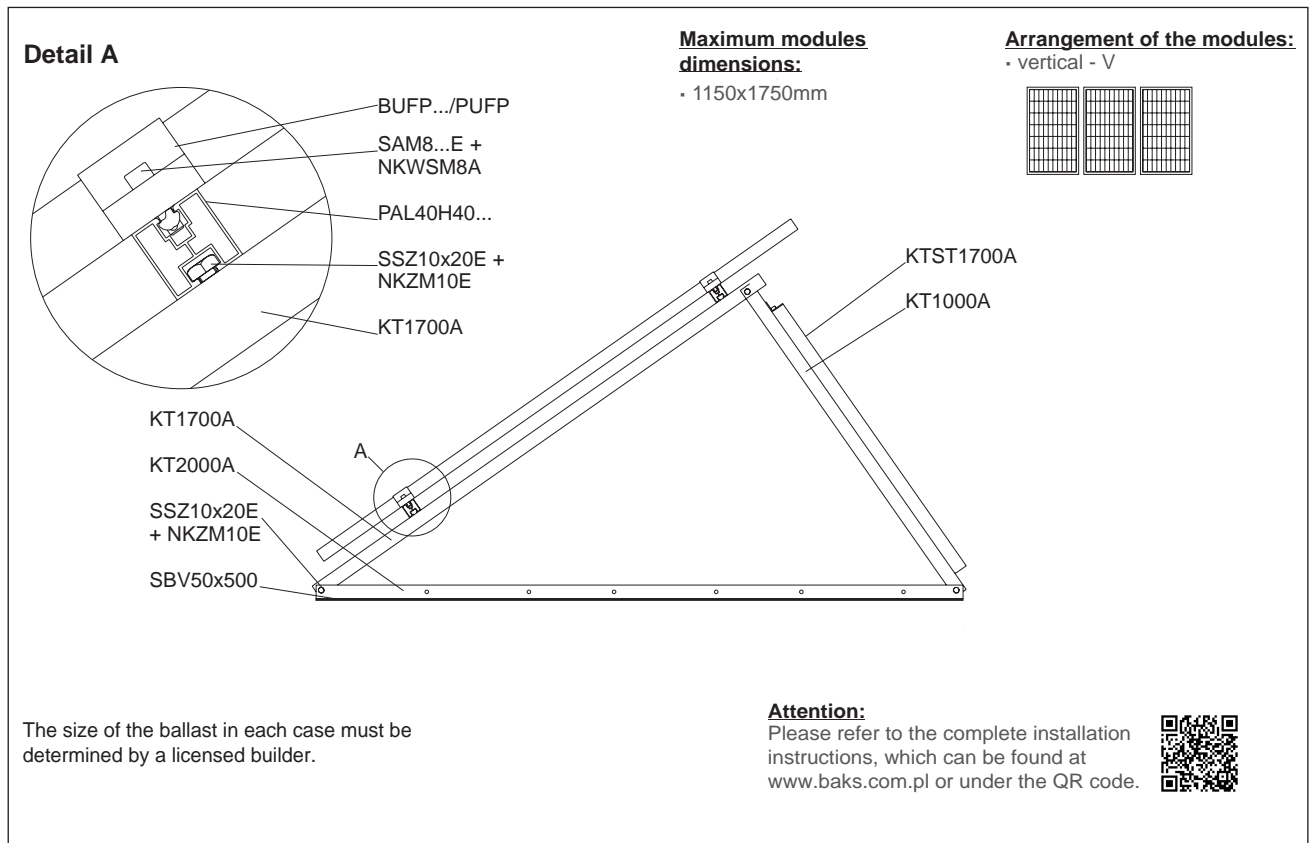



Mounting structures for the installation of photovoltaic panels on walls
System: E-VKRN

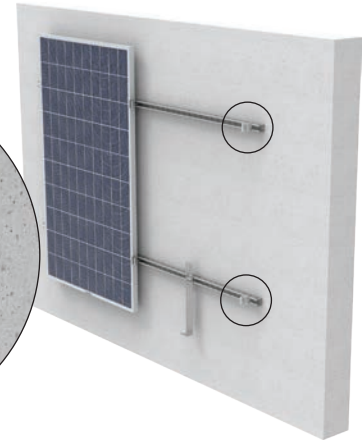
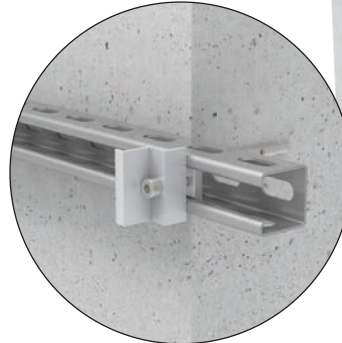

Structure description

Support system for quick installation of PV panels to building elevations.

Technical description:

Materials of the support system:
MC- Coated structural steel: Magnelis®, MagiZinc®, PosMAC
A- Aluminium
E- Stainless steel
F- Steel in zinc flake coating
 Structure tested for strength.

Advantages:

- quick installation
- low price
- high stability of the structure
- structure tested for strength
- steel in Magnelis® coating guarantees very high corrosion resistance
- clamps with integrated grounding pads

Warranty

BAKS provides a 10 year warranty period for the components included in the support structure - only if all conditions of the manufacturer's warranty are met.

Structure assembly variants:

- Anchored with anchors for concrete
- Anchored with chemical anchors for concrete

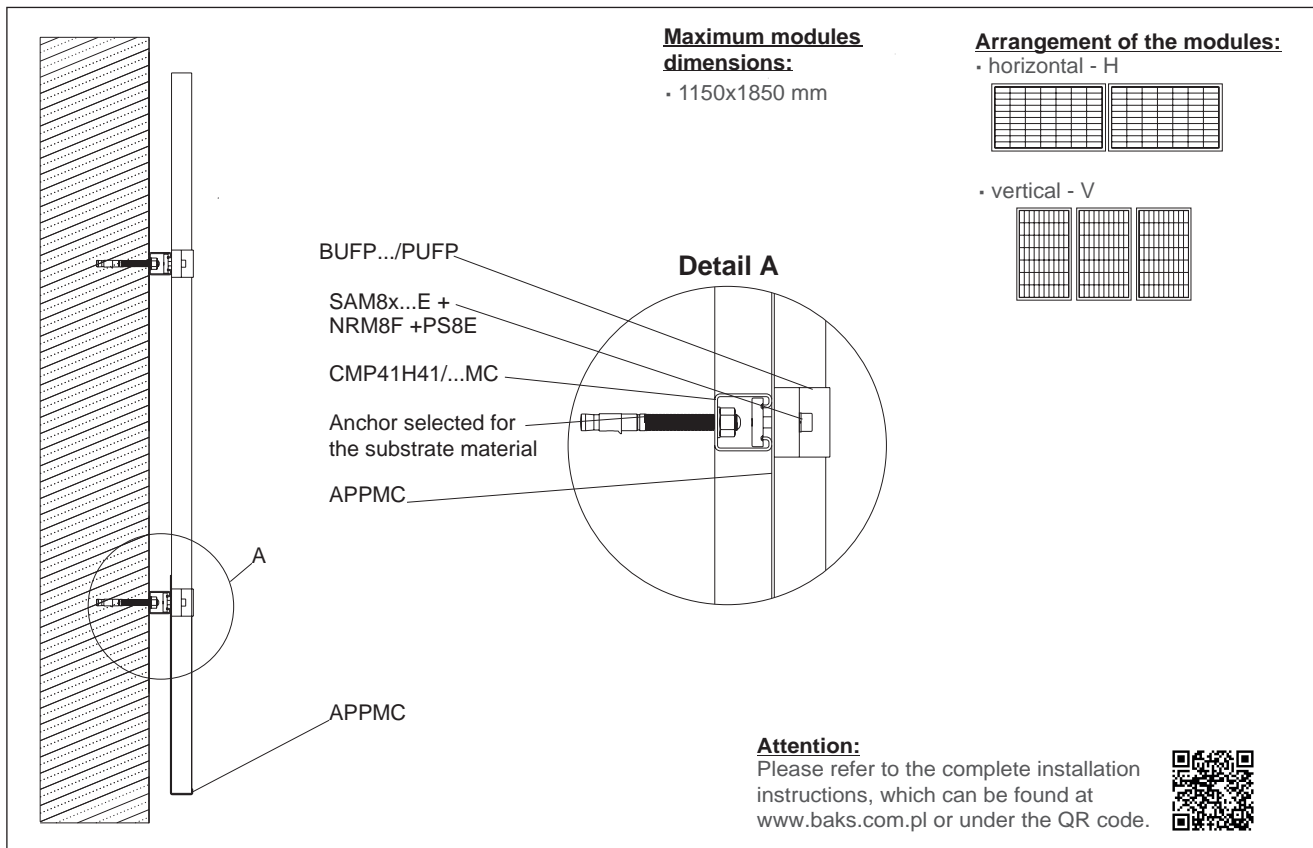



Mounting structures for the installation of photovoltaic panels on walls

System: E-VKTN (25°, 30°)

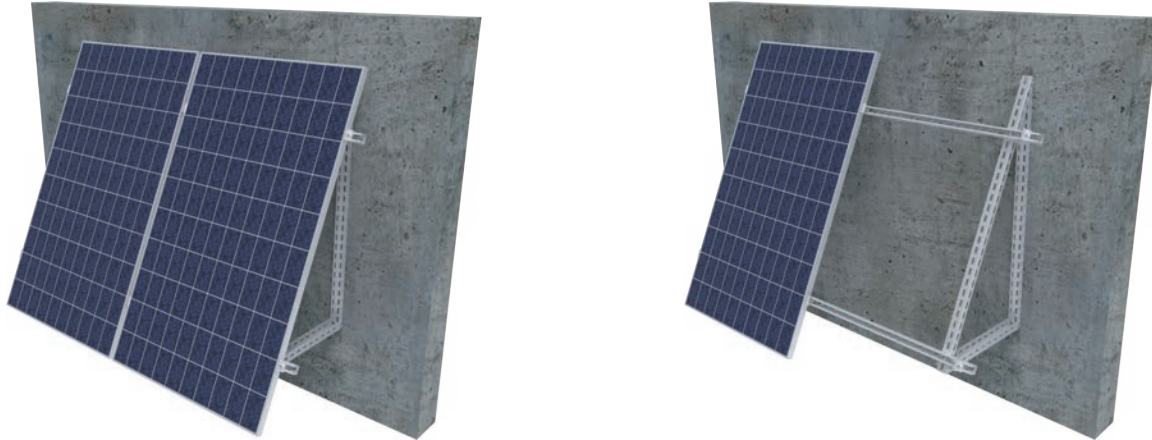

Structure description

Support system for quick installation of PV panels to building elevations.

Technical description:

Materials of the support system:

MC- Coated structural steel:
Magnelis®, MagiZinc®, PosMAC
A- Aluminium

E- Stainless steel

F- Steel in zinc flake coating

Structure tested for strength.

Advantages:

- quick installation
- low price
- high stability of the structure
- two inclination angle variants: 25° and 30°
- steel in Magnelis® coating guarantees very high corrosion resistance
- clamps with integrated grounding pads

Warranty

BAKS provides a 10 year warranty period for the components included in the support structure - only if all conditions of the manufacturer's warranty are met.

Structure assembly variants:

- Anchored with anchors for concrete
- Anchored with chemical anchors for concrete

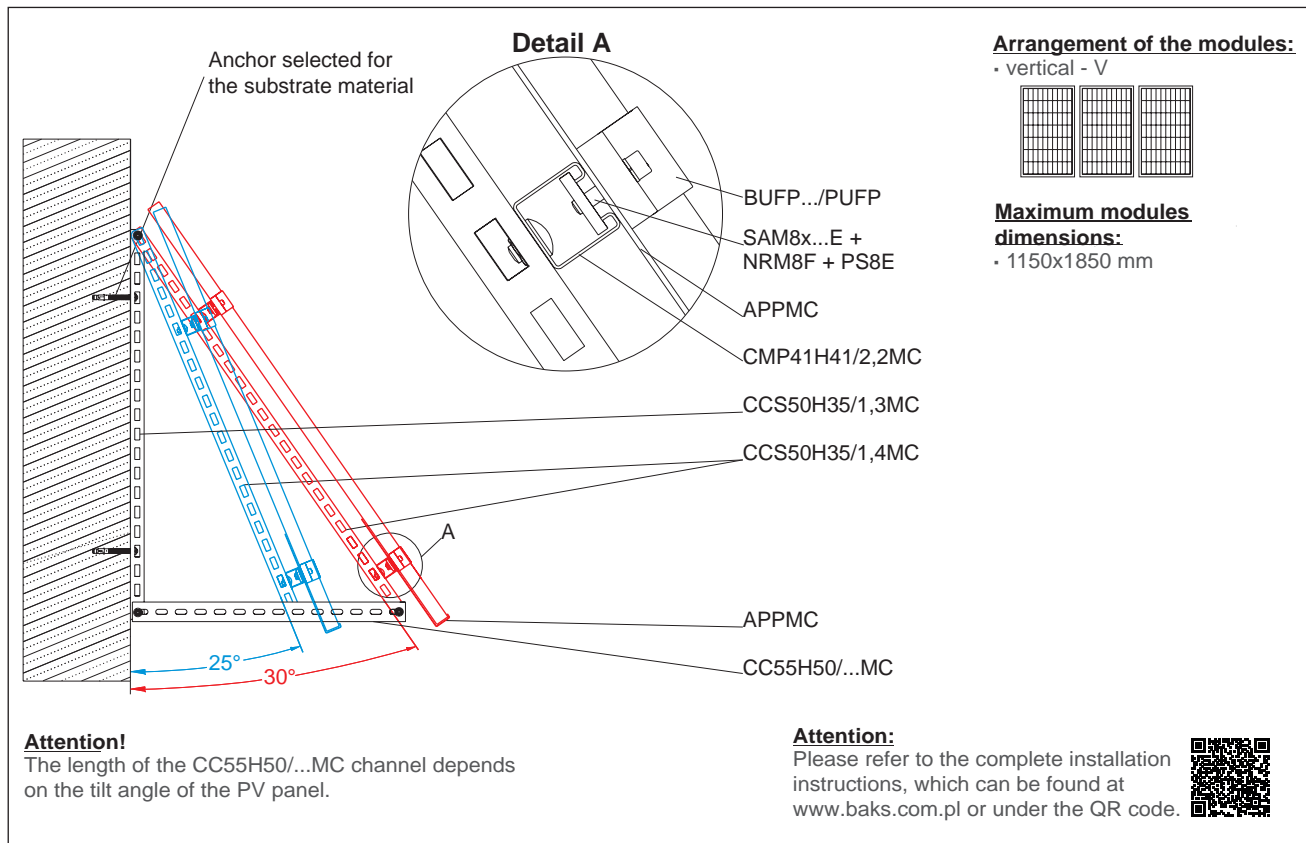



Mounting structures for the installation of photovoltaic panels on balcony railings
System: B-VPN

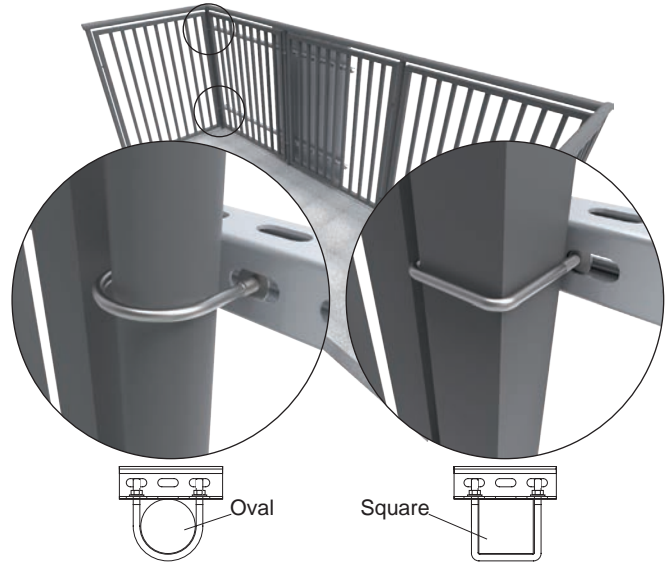
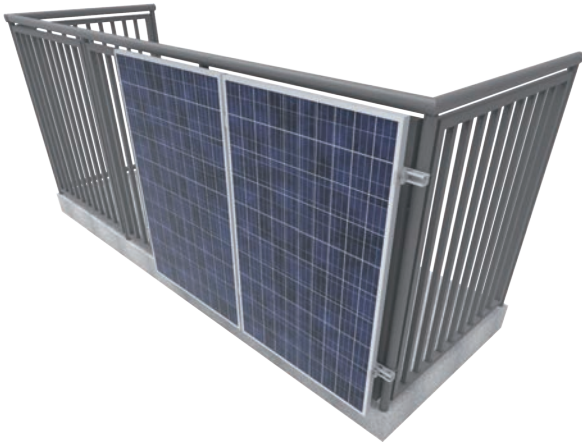

Structure description

Support system for easy installation of PV panels to balcony railings.

Technical description:

Materials of the support system:
MC- Coated structural steel: Magnelis®, MagiZinc®, PosMAC
A- Aluminium
E- Stainless steel
F- Steel in zinc flake coating
 Structure tested for strength.

Advantages:

- quick installation
- low price
- high stability of the structure
- structure tested for strength
- steel in Magnelis® coating guarantees very high corrosion resistance
- clamps with integrated grounding pads

Structure assembly variants:

- screwed to balcony railings with u-bolts of round or square section

Warranty

BAKS provides a 10 year warranty period for the components included in the support structure - only if all conditions of the manufacturer's warranty are met.

Detail A

CMP41H41/...MC
 CY...
 A
 APPMC

SAM8...E + NRM8F
 BUFP.../PUFP
 NSM8E
 PW8E
 APPMC

Maximum modules dimensions:

- 1150x1850 mm

Arrangement of the modules:

- horizontal - H

- vertical - V

Attention:
 Please refer to the complete installation instructions, which can be found at www.baks.com.pl or under the QR code.



Mounting structures for the installation of photovoltaic panels on balcony railings
System: B-HKAN



Structure description

Support system for easy installation of PV panels to balcony railings.

Technical description:

Materials of the support system:
 MC- Coated structural steel:
 Magnelis®, MagiZinc®, PosMAC
 A- Aluminium
 E- Stainless steel

Structure assembly variants:

- screwed to balcony railings with u-bolts of round or square section

Advantages:

- quick installation
- low weight of the structure
- low price
- high stability of the structure
- structure tested for strength
- steel in Magnelis® coating guarantees very high corrosion resistance
- clamps with integrated grounding pads

Warranty

BAKS provides a 10 year warranty period for the components included in the support structure - only if all conditions of the manufacturer's warranty are met.

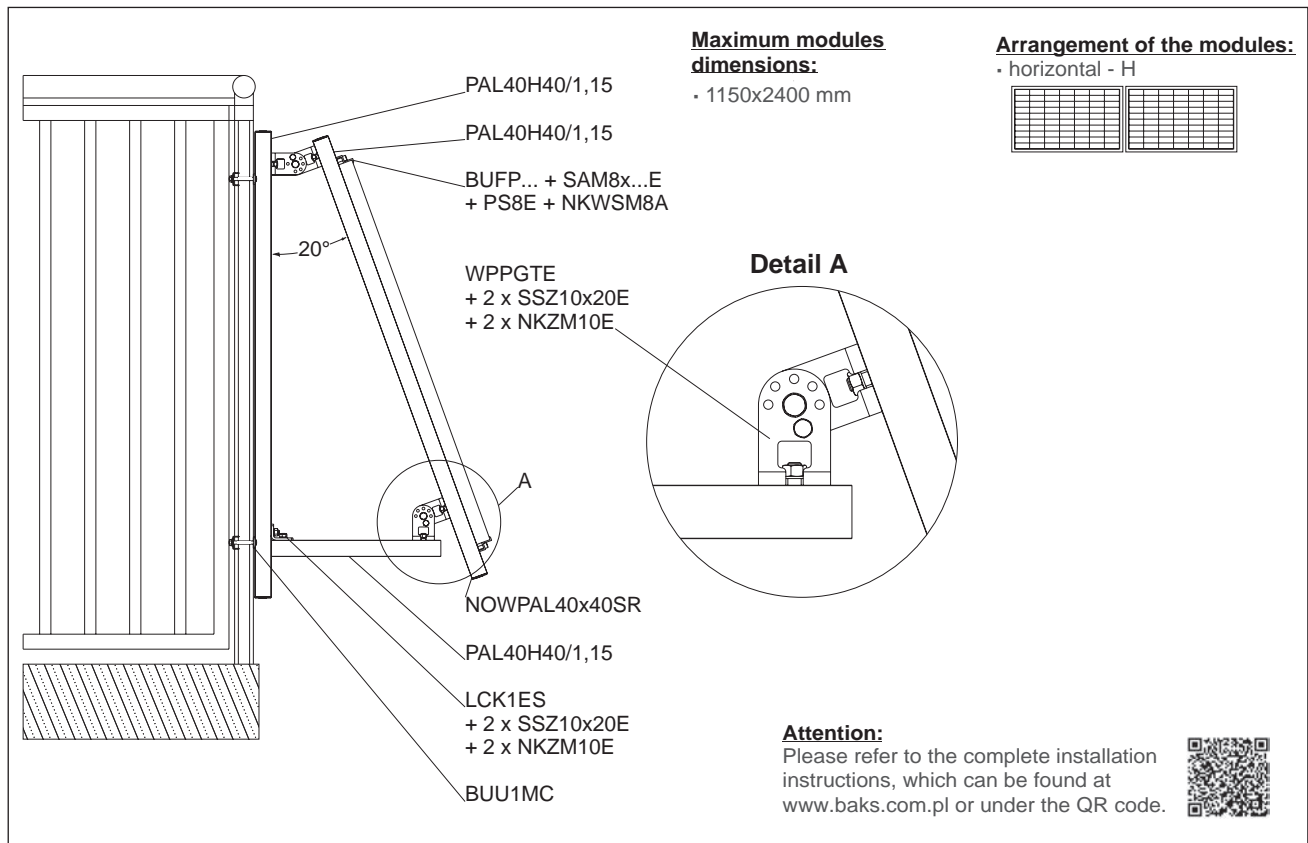



Free-standing CARPORT Structure System: K1, K2



K1 - basic variant

K2 - basic variant

Available structure variants	basic variant					variant with sheet-metal flashing "O"			
	Carport	Symbol for basic variant	Catalogue No.	Carport Extension Symbol	Catalogue No.	Symbol for variant with sheet-metal flashing	Catalogue No.	Carport Extension Symbol	Catalogue No.
Structure with Magnelis® coating	SINGLE panel dimensions [1722x1134 mm]	K1	811110	DK1	811112	K1O	811111	DK1O	811113
	DOUBLE panel dimensions [1903x1134 mm]	K2	811310	DK2	811312	K2O	811311	DK2O	811313
Structure with Magnelis® coating, powder-coated "L"	SINGLE panel dimensions [1722x1134 mm]	K1L	8111102	DK1L	8111122	K1OL	8111112	DK1OL	8111132
	DOUBLE panel dimensions [1903x1134 mm]	K2L	8113102	DK2L	8113122	K2OL	8113112	DK2OL	8113132

Structure description

Free-standing CARPORT structure on four vertical legs, allowing vehicle entry/exit and safe parking.

Horizontal module layout.

Module tilt angle: 10°.

The CARPORT is designed for wind zone 1 and snow zones 1 to 3.

Single carport (1 parking space) panel dimensions 1722 x 1134 mm

Single carport with extension (2 parking spaces) panel dimensions 1722 x 1134 mm

Double carport (2 parking spaces) panel dimensions 1903 x 1134 mm

Double carport with extension (4 parking spaces) panel dimensions 1903 x 1134 mm

1903 x 1134 mm

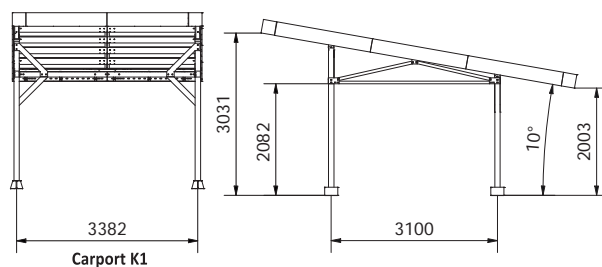

Advantages:

- Length of elements on the pallet does not exceed 3000 mm
- Suitable for storage on indoor warehouse racks, preventing stains and discoloration caused by weather conditions
- Carport manufactured from steel components with Magnelis® coating
- Carport manufactured without welded elements
- Carport prepared for installation of sheet-metal flashings and gutters (optional)
- Installation on concrete surfaces or paving blocks does not require foundations (subsoil stability must be confirmed)
- Installation on natural ground using small, standard prefabricated foundations weighing approx. 100 kg each
- Carport suitable for self-assembly by 2–3 people
- Solutions tested for structural strength
- Possibility of modular expansion of the carport
- Delivered on EUR pallets

Options:

- Sheet-metal flashings
- Structure for mounting inverter and electrical distribution boards
- Powder coating

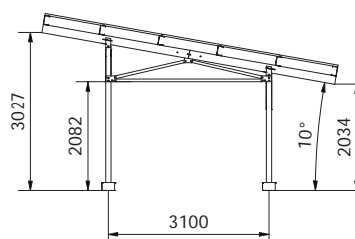
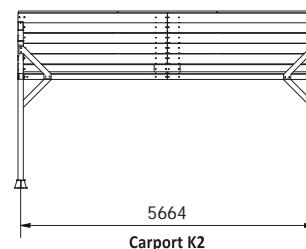

Detailed information on the products can be found on pages 70-144

Methods of Installing the CARPORT structure to the Ground

Mounting variants of the structure:

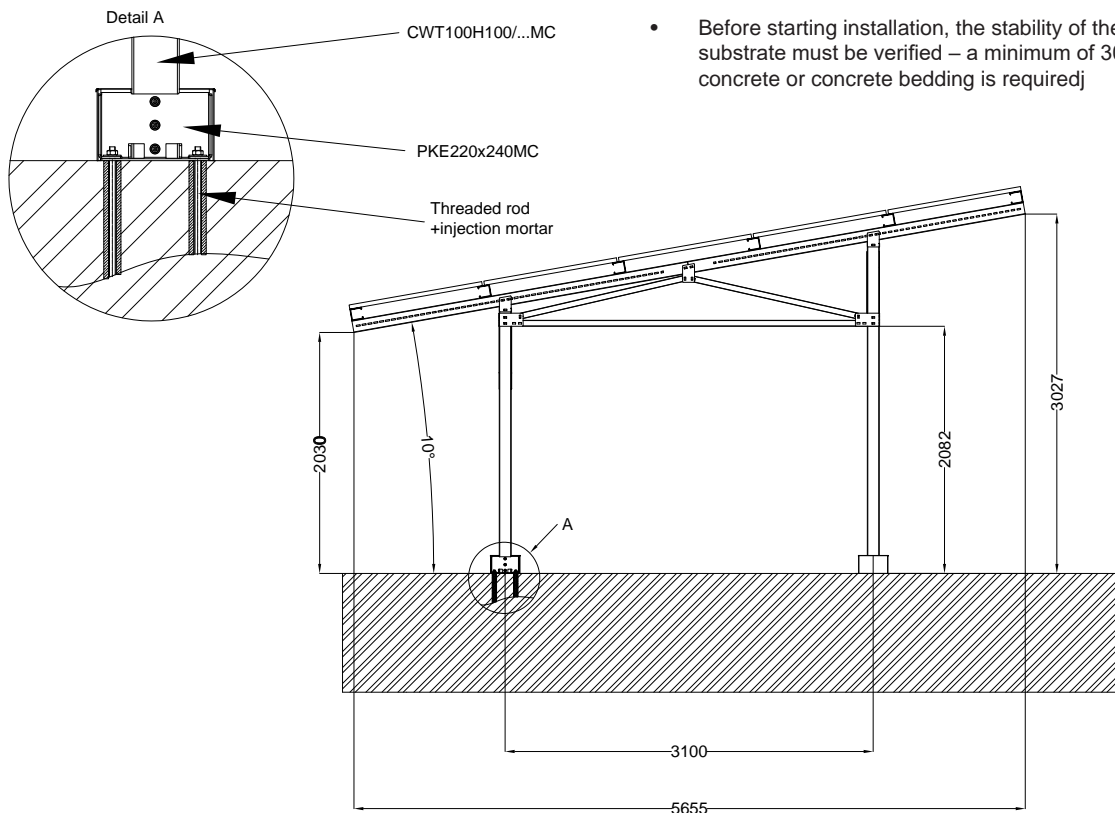
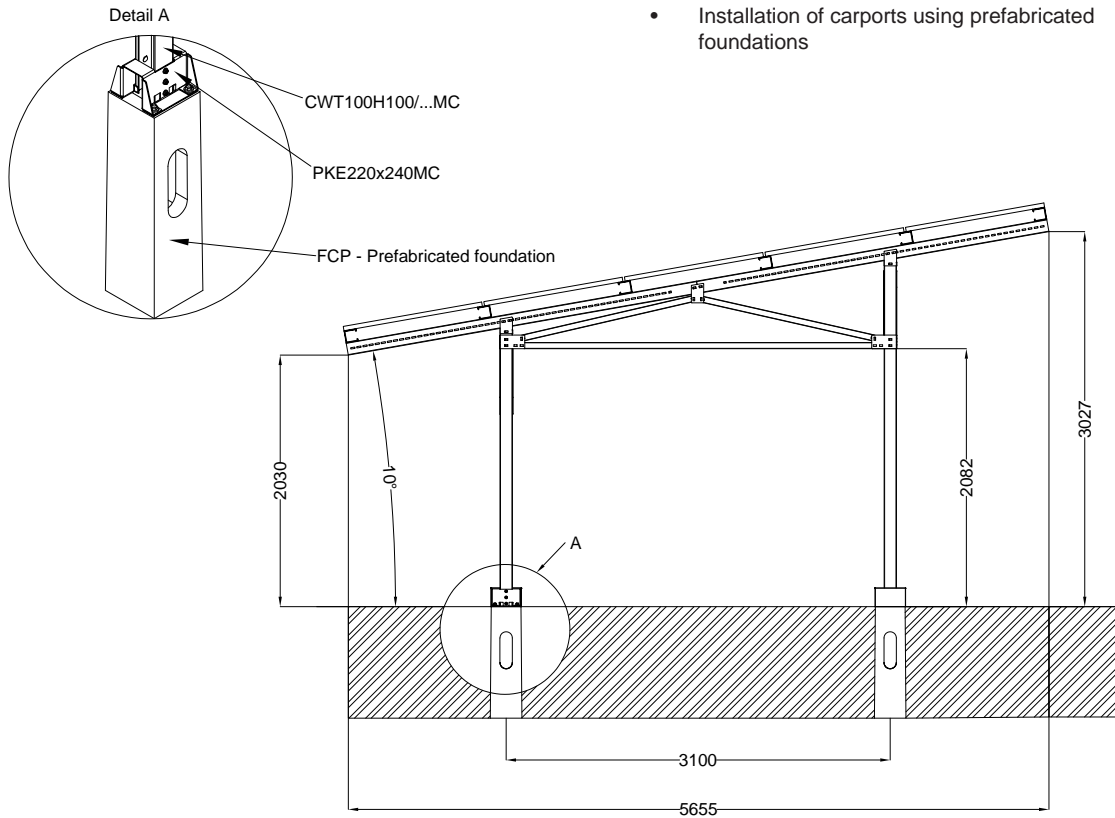



NEW!
OPTION TO ORDER A UNIVERSAL MOUNTING PLATE FOR INVERTERS AND ELECTRICAL DISTRIBUTION BOARDS

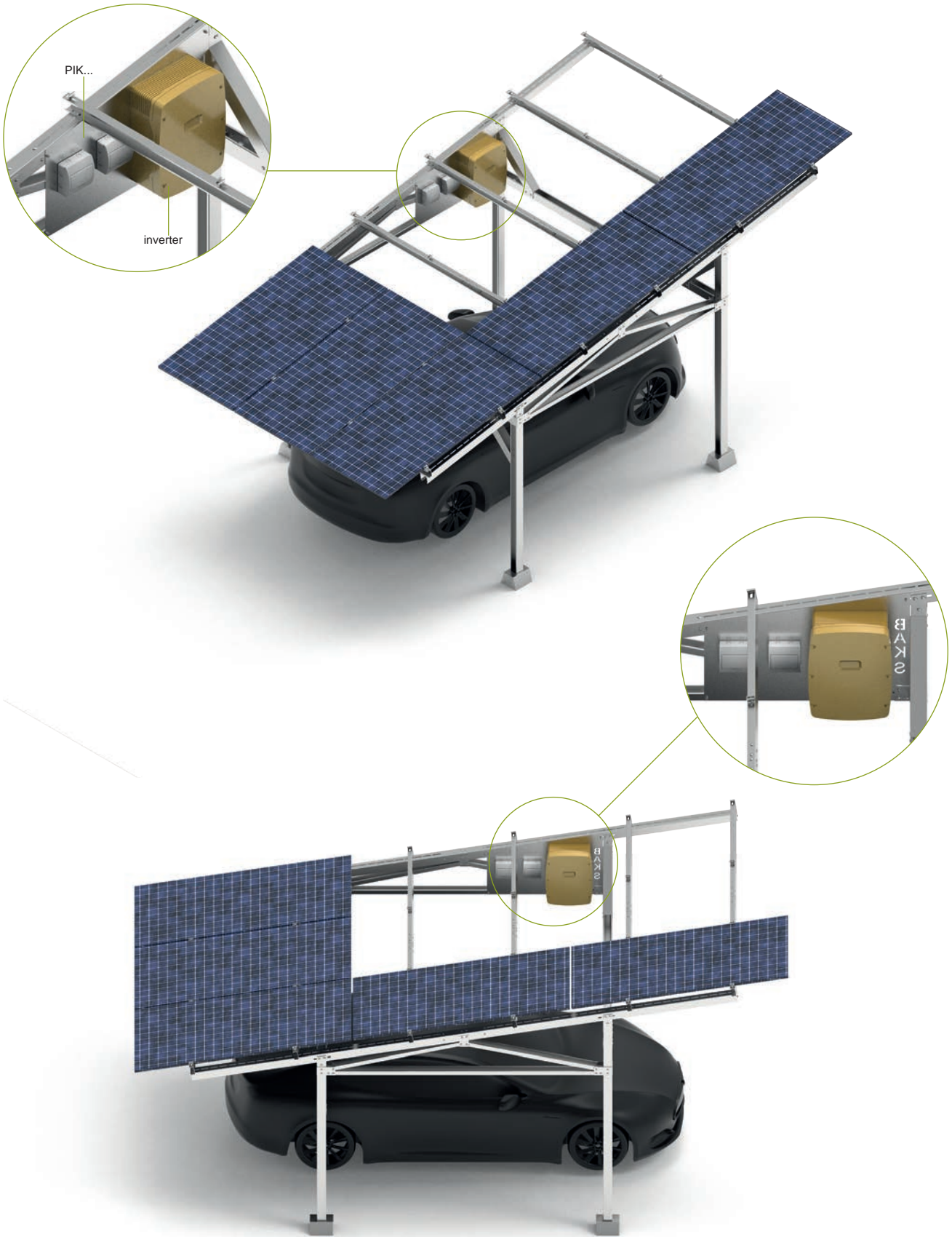



**Free-standing CARPORT structure
on 4 vertical legs
System: K1**

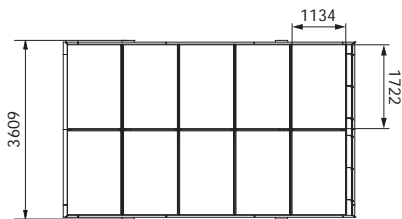
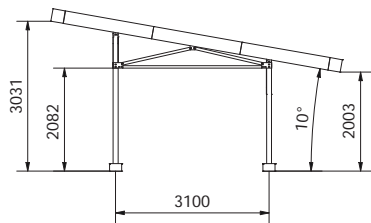
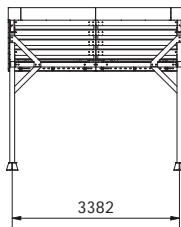
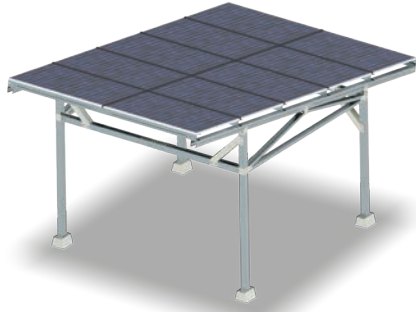

Structure Description

Free-standing CARPORT structure on four vertical legs, allowing vehicle entry/exit and safe parking.
Possibility to use panels from various manufacturers with dimensions: for K1 – 1722 x 1134 mm

Technical Description:

Mounting system materials:

MC- Structural steel with coating:

Magnelis®, MagiZinc®, PosMAC

E- Stainless steel

F- Zinc flake-coated steel

The structure has been tested for structural strength.

- L- powder coating in black color RAL 9005

Module Layout:

- Horizontal-H

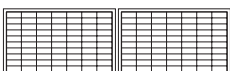

**Single carport extension
(for one vehicle)
System: DK1**

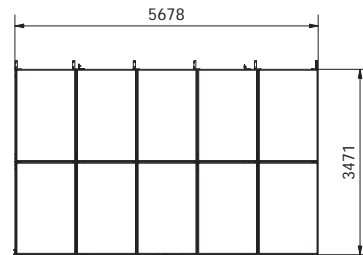
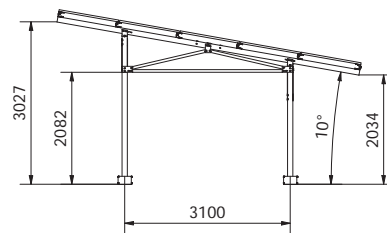
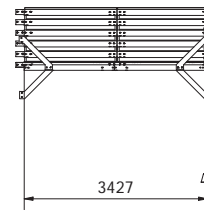

Structure Description

Free-standing CARPORT extension structure allowing vehicle entry/exit and safe parking.
Possibility to use panels from various manufacturers with dimensions: for DK1 – 1722 x 1134 mm

- possibility of connecting extensions into continuous rows

Technical Description:

Mounting system materials:

MC- Structural steel with coating:

Magnelis®, MagiZinc®, PosMAC

E- Stainless steel

F- Zinc flake-coated steel

The structure has been tested for structural strength.

- L- powder coating in black color RAL 9005

Module Layout:

- Horizontal-H

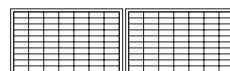



**Free-standing CARPORT structure with sheet-metal flashing on 4 vertical legs
System: K10**

**Single carport extension with sheet-metal flashing (for one vehicle)
System: DK10**

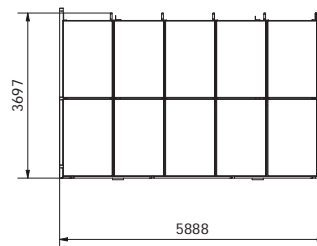
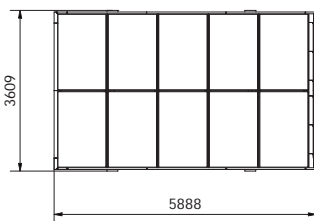
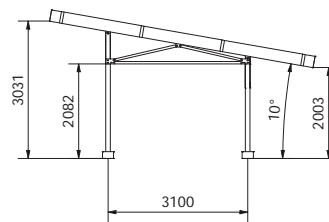
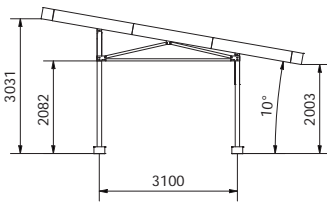
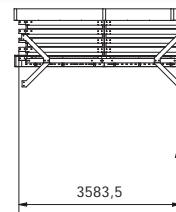
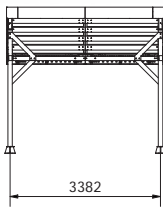

Structure Description

Free-standing CARPORT structure on four vertical legs, allowing vehicle entry/exit and safe parking.

- Possibility to use panels from various manufacturers with dimensions: for K10 – 1722 × 1134 mm

Technical Description:

Mounting system materials:

MC- Structural steel with coating:

Magnelis®, MagiZinc®, PosMAC

E- Stainless steel

F- Zinc flake-coated steel

The structure has been tested for structural strength.

- L- powder coating in black color RAL 9005

Module Layout:

- Horizontal-H

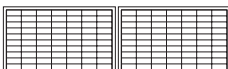

Structure Description

Free-standing CARPORT extension structure allowing vehicle entry/exit and safe parking.

- Possibility to use panels from various manufacturers with dimensions: for DK10 – 1722 × 1134 mm
- Possibility of connecting extensions into continuous rows

Technical Description:

Mounting system materials:

MC- Structural steel with coating:

Magnelis®, MagiZinc®, PosMAC

E- Stainless steel

F- Zinc flake-coated steel

The structure has been tested for structural strength.

- L- powder coating in black color RAL 9005

Module Layout:

- Horizontal-H

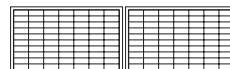



**Free-Standing CARPORT structure
on 4 vertical legs
System: K2**

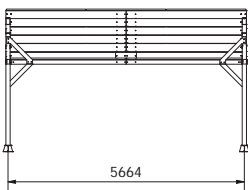
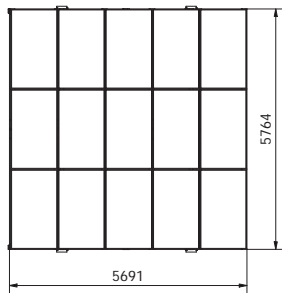
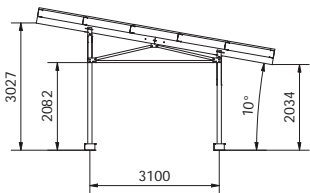

Structure Description

Free-standing CARPORT structure on four vertical legs, allowing vehicle entry/exit and safe parking.

- Compatible with panels from various manufacturers with dimensions: for K2 – 1903 × 1134 mm

Technical Description:

Mounting system materials:

MC- Structural steel with coating:

Magnelis®, MagiZinc®, PosMAC

E- Stainless steel

F- Zinc flake-coated steel

The structure has been tested for structural strength.

- L- powder coating in black color RAL 9005

Module Layout:

- Horizontal-H

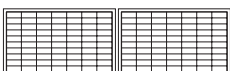

**Double Carport Extension
(for one vehicle)
System: DK2**

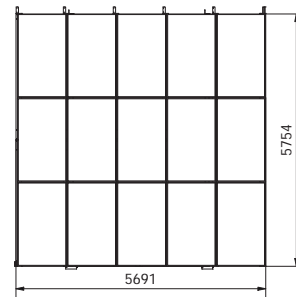
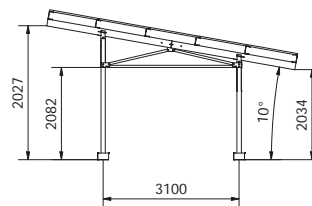
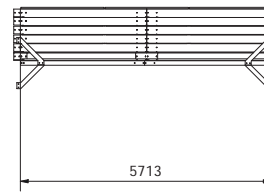

Structure Description

Free-standing CARPORT extension structure allowing vehicle entry/exit and safe parking.

- Compatible with panels from various manufacturers with dimensions: for DK2 – 1903 × 1134 mm
- Possibility of connecting extensions into continuous rows

Technical Description:

Mounting system materials:

MC- Structural steel with coating:

Magnelis®, MagiZinc®, PosMAC

E- Stainless steel

F- Zinc flake-coated steel

The structure has been tested for structural strength.

- L- powder coating in black color RAL 9005

Module Layout:

- Horizontal-H

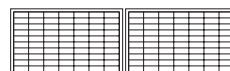



**Free-Standing CARPORT structure with sheet-metal flashing on 4 vertical legs
System: K20**

**Double Carport Extension with sheet-metal flashing (for two vehicle)
System: DK20**

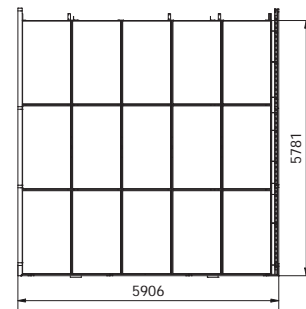
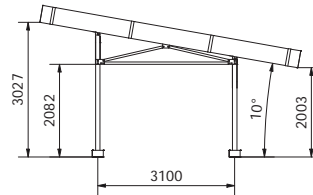
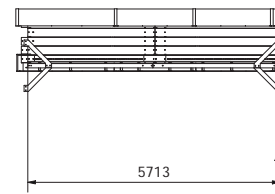
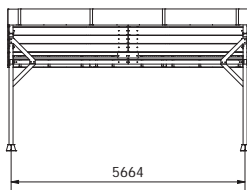
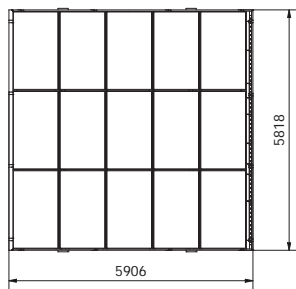
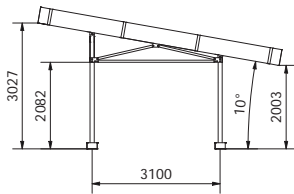

Structure Description

Free-standing CARPORT structure on four vertical legs, allowing vehicle entry/exit and safe parking.

- Compatible with panels from various manufacturers with dimensions: for K2 – 1903 × 1134 mm

Technical Description:

Mounting system materials:

MC- Structural steel with coating:

Magnelis®, MagiZinc®, PosMAC

E- Stainless steel

F- Zinc flake-coated steel

The structure has been tested for structural strength.

- L- powder coating in black color RAL 9005

Module Layout:

- Horizontal-H

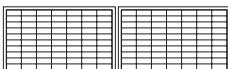

Structure Description

Free-standing CARPORT extension structure allowing vehicle entry/exit and safe parking.

- Compatible with panels from various manufacturers with dimensions: for DK20 – 1903 × 1134 mm
- Possibility of connecting extensions into continuous rows

Technical Description:

Mounting system materials:

MC- Structural steel with coating:

Magnelis®, MagiZinc®, PosMAC

E- Stainless steel

F- Zinc flake-coated steel

The structure has been tested for structural strength.

- L- powder coating in black color RAL 9005

Module Layout:

- Horizontal-H

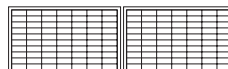



Free-Standing CARPORT structure on 4 vertical legs
System: KP1

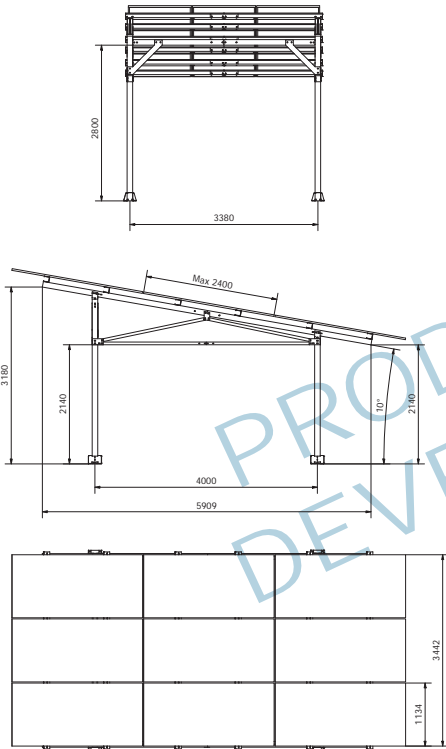

Structure Description

Free-standing CARPORT structure on four vertical legs, allowing vehicle entry/exit and safe parking.

- Compatible with panels from various manufacturers with dimensions: for KP1 – length range (2100–2400) mm and fixed width 1134 mm

Technical Description:

Mounting system materials:

MC- Structural steel with coating:

Magnelis®, MagiZinc®, PosMAC

E- Stainless steel

F- Zinc flake-coated steel

The structure has been tested for structural strength.

- L- powder coating in black color RAL 9005

Module Layout:

- Vertical - V

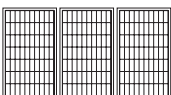

Free-Standing CARPORT structure on 4 vertical legs
System: KP2

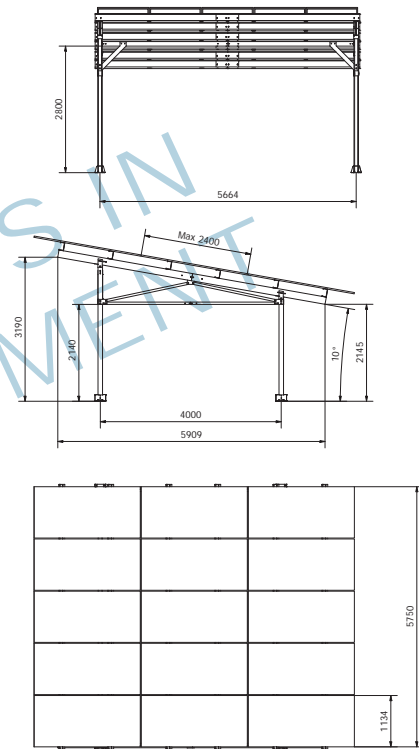

Structure Description

Free-standing CARPORT structure on four vertical legs, allowing vehicle entry/exit and safe parking.

- Compatible with panels from various manufacturers with dimensions: for KP2 – length range (2100–2400) mm and fixed width 1134 mm

Technical Description:

Mounting system materials:

MC- Structural steel with coating:

Magnelis®, MagiZinc®, PosMAC

E- Stainless steel

F- Zinc flake-coated steel

The structure has been tested for structural strength.

- L- powder coating in black color RAL 9005

Module Layout:

- Vertical - V

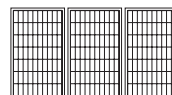

Free-Standing CARPORT structure on VI-Leg Arrangement System: KVI, KVIO



Structure Description

Free-standing CARPORT structure on legs arranged in VI layout, allowing vehicle entry/exit and safe parking under the panel canopy.

Advantages:

- Allows easy parking of one or two vehicles
- Protects vehicles from weather conditions
- Structurally tested for strength
- Modern design with optional powder coating
- Simple and fast assembly due to profiles with dedicated perforations
- Compatible with photovoltaic panels of various sizes

Module Layout:

• Horizontal-H

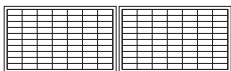

Optional on request:

- Powder coating in any RAL color
- Mounting system for inverters (free-standing or mounted on the carport)
- Seals for carport ensuring weather tightness
- Sheet-metal flashing for mounting on carport edges

Technical Description:

Mounting system materials:

MC- Structural steel with Magnelis®, MagiZinc®, PosMac (structural profiles)

L- powder coating in black color RAL 9005

E- Stainless steel

F- Zinc flake-coated steel (fastening screws)

- The structure has been tested for structural strength

Warranty

BAKS provides a 10-year warranty on components of the supporting structure, provided all manufacturer warranty conditions are met. Extension of warranty period is possible upon meeting additional requirements.

Detailed information on the products can be found on pages 70-144



Free-Standing CARPORT structure on V-leg arrangement

System: KV, KVO



Structure Description

Konstrukcja wolnostojąca typu CARPORT na nogach w układzie V umożliwiającą wjazd/wyjazd i bezpieczne parkowanie samochodu pod połacią paneli.

Advantages:

- Allows easy parking of one or two vehicles
- Protects vehicles from weather conditions
- Structurally tested for strength
- Modern design with optional powder coating
- Simple and fast assembly due to profiles with dedicated perforations
- Compatible with photovoltaic panels of various sizes

Module Layout:

- Horizontal-H

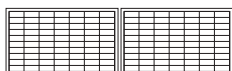

Optional on request:

- Powder coating in any RAL color
- Mounting system for inverters (free-standing or mounted on the carport)
- Seals for carport ensuring weather tightness
- Sheet-metal flashing for mounting on carport edges

Technical Description:

Mounting system materials:

MC- Structural steel with Magnelis®, MagiZinc®, PosMac (structural profiles)

L- powder coating in black color RAL 9005

E- Stainless steel

F- Zinc flake-coated steel (fastening screws)

- The structure has been tested for structural strength

Warranty

BAKS provides a 10-year warranty on components of the supporting structure, provided all manufacturer warranty conditions are met. Extension of warranty period is possible upon meeting additional requirements.

Aluminium profile	PAL40H40...	mat.: A	option: L		
symbol	catalogue number	dimension L [mm]	weight 1 pc. [kg]	quantity per package [pcs.]	STM
PAL40H40/0,4	894504	400	0.33	1	
PAL40H40/1,15	894510	1150	0.94	1	
PAL40H40/1,3	894613	1300	1.06	1	
PAL40H40/2,1	894621	2100	1.72	1	
PAL40H40/2,2	894622	2200	1.80	1	
PAL40H40/2,4	894624	2400	1.97	1	
PAL40H40/3,15	894631	3150	2.58	1	
PAL40H40/3,3	894633	3300	2.70	1	
PAL40H40/3,6	894636	3600	2.95	1	
PAL40H40/4,4	894644	4400	3.60	1	
PAL40H40/6,3	894663	6300	5.15	1	
PAL40H40/6,6	894666	6600	5.39	1	

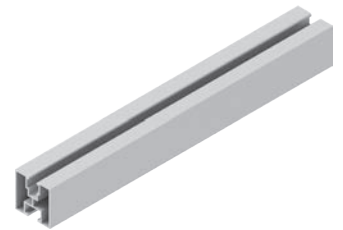
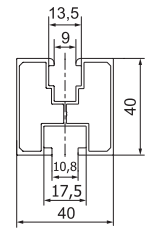

Use:

Support of panels in pitched roof and flat roof structures, mounting panels to the support structure.

Additional information:

- stable support of panels for pitched roof and flat roof structures
- width of sockets in the profile prevents rotation of hexagon nuts and bolts (M8 for the top socket and M10 for the lower socket)
- special shape of the profile to increase its strength
- fast and strong screwless connection of two profiles using LPAN connectors, press-fitted without tools
- radii in the mounting slot ensure smooth installation of CLICK-type clamps without excessive force
- very good value for money
- the profile has undergone strength testing and meets European standards, confirmed by a TUV certificate

Aluminium Profile Connector	LPAN40	mat.: MC			
symbol	catalogue number	weight 1 pc. [kg]	quantity per package [pcs.]		STM
LPAN40	890512	0.06	100		

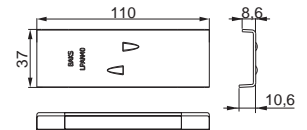

Use:

Screwless connection of aluminium profiles.

Additional information:

- bevelled ends facilitate initial insertion of the connector into the profile
- the shape of the connector provides a very stable profile connection
- stops for the depth of insertion of the fastener into the profile
- made of Magnelis-coated material with very high corrosion resistance
- high strength parameters

A - Assembly of NOPAL40x40CZ Protection Caps at the ends of the PAL40H40 Aluminium Profile
 B - Assembly of LPAN40 Aluminium Profile Connectors to connect PAL40H40 Aluminium profiles

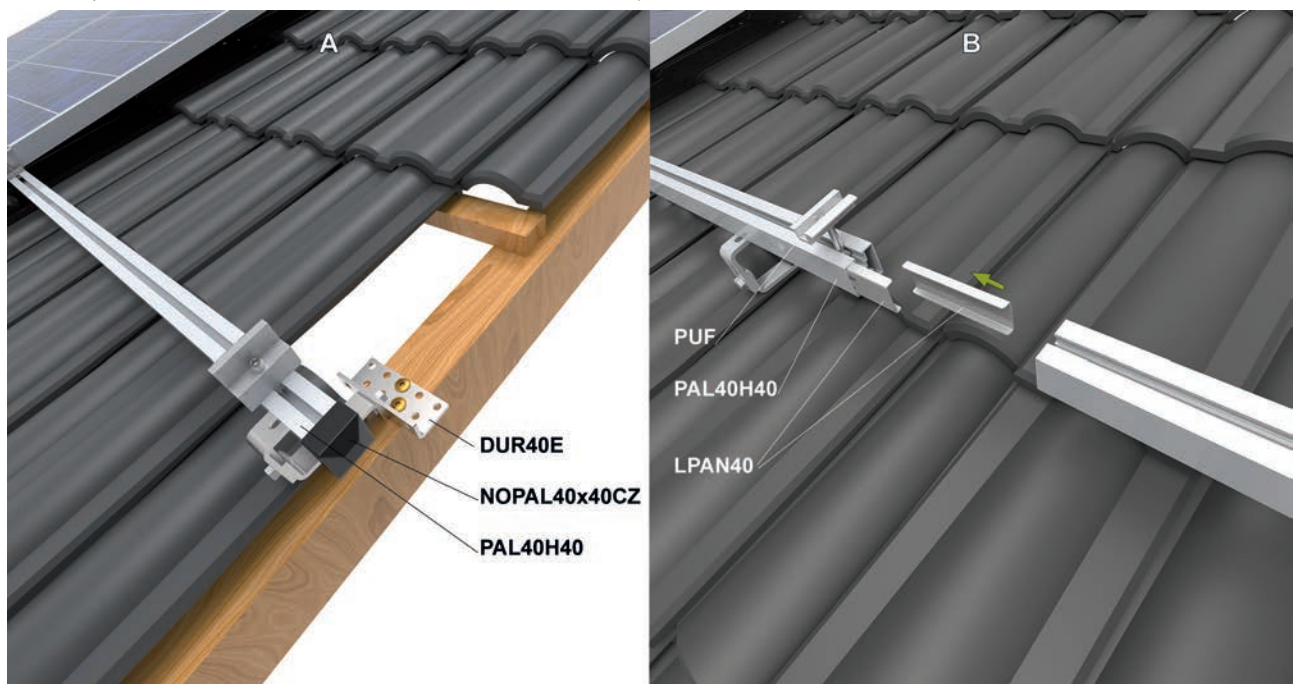

A - aluminium, L - painting in standard RAL colour



Protective cap for aluminium profile **NOPAL...**

mat.: PE

symbol	catalogue number	dimension a [mm]	quantity per package [pcs.]
NOPAL40x40CZ	890403	40	100
NOPAL40x40SR	890401	40	100

STM

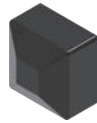
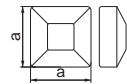

Use:

Termination of PAL40H40... aluminium profiles.

Additional information:

- improved visual aspect of PV installations
- improved safety for fitters during installation
- improved visual aspect of PV installations
- improved safety for fitters during installation

Protective cap for aluminium profile **NOWPAL40x40SR**

mat.: PE

symbol	catalogue number	dimension a [mm]	quantity per package [pcs.]
NOWPAL40x40SR	890404	40	100

N STM



Use:

Termination of PAL40H40... aluminium profiles.

Additional information:

- improved visual aspect of PV installations
- improved safety for fitters during installation
- improving the safety of installers during installation and users after installation

A - Assembly of NOPAL40x40CZ Protection Caps at the ends of the PAL40H40 Aluminium Profile
 B - Assembly of LPAN40 Aluminium Profile Connectors to connect PAL40H40 Aluminium profiles

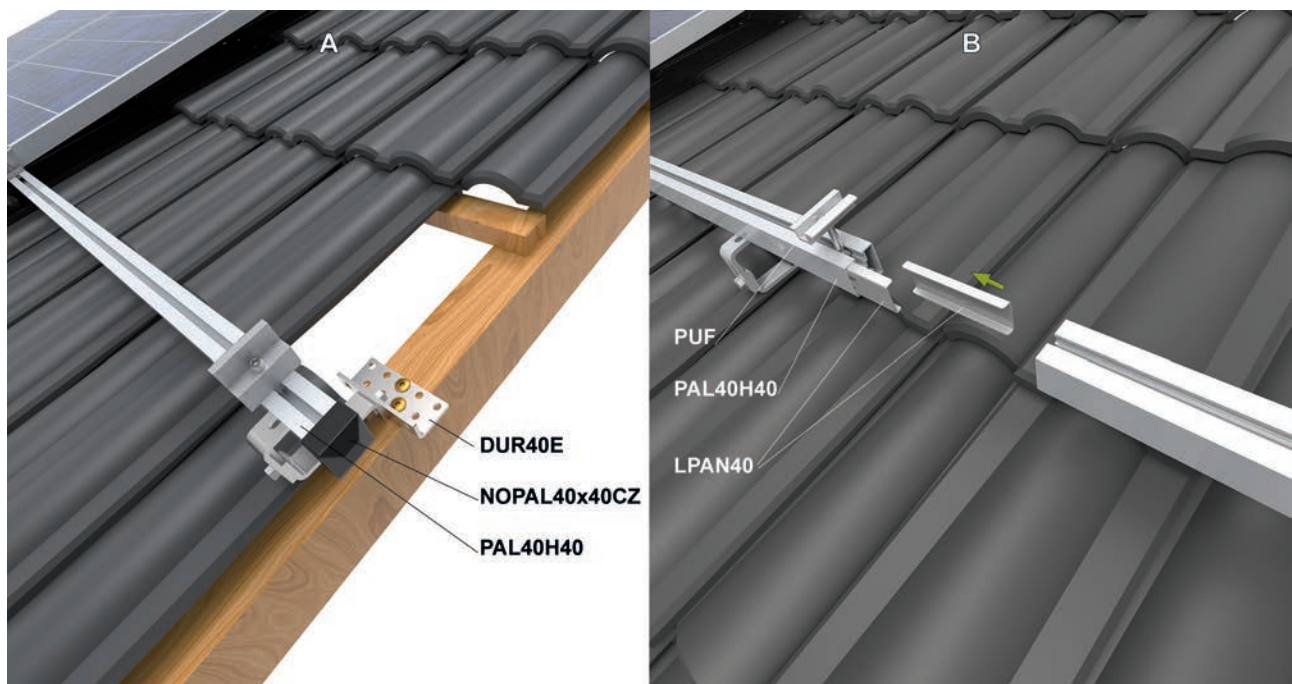

PE - polyethylene

Aluminium profile PAL40H80/6,6 mat.: A option: L

symbol	catalogue number	dimension L [mm]	weight 1 pc. [kg]	quantity per package [pcs.]
PAL40H80/6,6	894866	6600	12.20	1

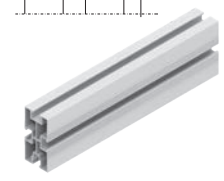
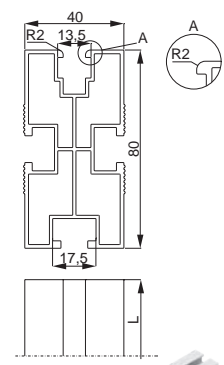

Use:
Support of panels in pitched roof and flat roof structures, mounting panels to the support structure.

Additional information:

- stable support of panels for pitched roof and flat roof structures
- width of sockets in the profile prevents rotation of hexagon nuts and bolts (M8 for the top socket and M10 for the lower socket)
- special shape of the profile to increase its strength
- modified upper slot for better installation of CLICK-type clamps
- radii in the mounting slot ensure smooth installation of CLICK-type clamps without excessive force
- improved panel ventilation thanks to increased distance from the roof covering
- side slots for M10 bolts increasing mounting possibilities

Aluminium profile PAL40H120/6,6 mat.: A option: L

symbol	catalogue number	dimension L [mm]	weight 1 pc. [kg]	quantity per package [pcs.]
PAL40H120/6,6	894266	6600	18.30	1

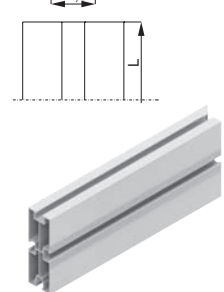
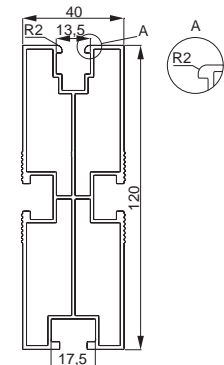

Use:
Support of panels in pitched roof and flat roof structures, mounting panels to the support structure.

Additional information:

- stable support of panels for pitched roof and flat roof structures
- width of sockets in the profile prevents rotation of hexagon nuts and bolts (M8 for the top socket and M10 for the lower socket)
- special shape of the profile to increase its strength
- modified upper slot for better installation of CLICK-type clamps
- radii in the mounting slot ensure smooth installation of CLICK-type clamps without excessive force
- improved panel ventilation thanks to increased distance from the roof covering
- side slots for M10 bolts increasing mounting possibilities

Installation of the DS-V4 structure on a pitched roof using PAL40H80 aluminum profiles

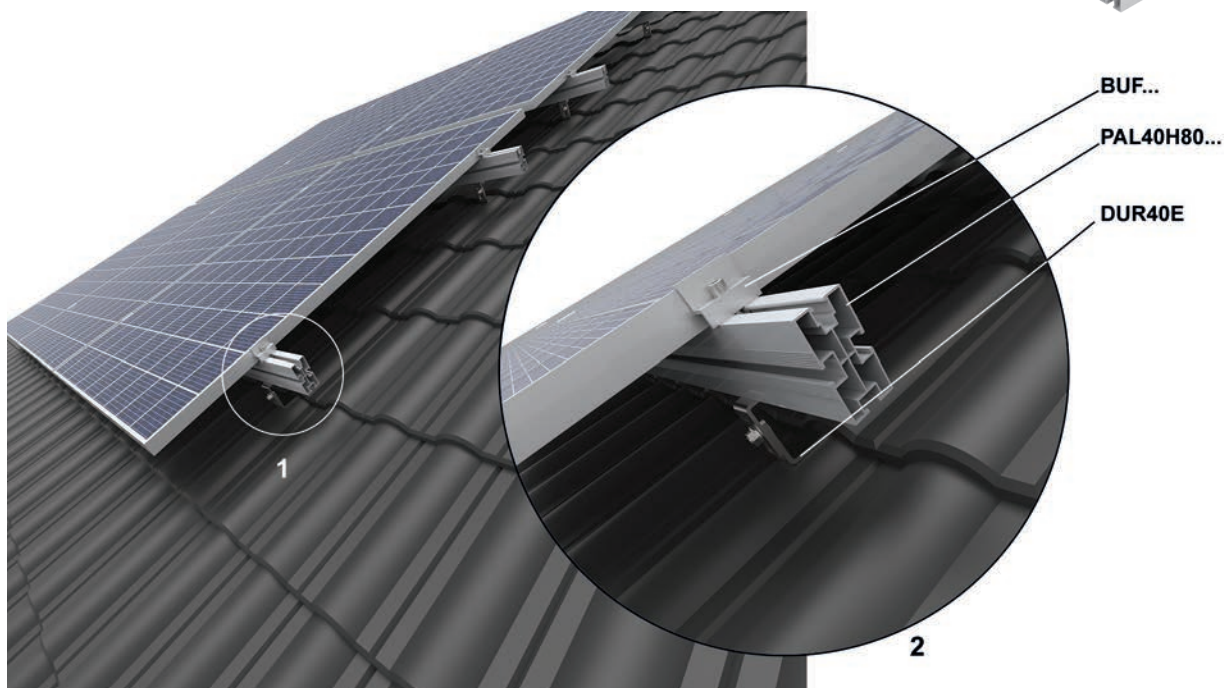



Aluminium profile PAL30H32... mat.: A option: L

symbol	catalogue number	dimension L [mm]	weight 1 pc. [kg]	quantity per package [pcs.]
PAL30H32/1,15	8932210	1150	0.82	1
PAL30H32/2,1	893221	2100	1.50	1
PAL30H32/2,2	893222	2200	1.57	1
PAL30H32/3,15	893231	3150	2.25	1
PAL30H32/3,3	893233	3300	2.36	1

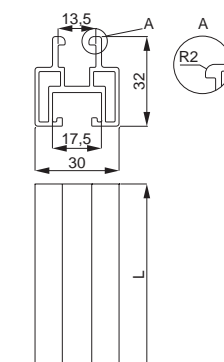

Use:

Support of panels in pitched roof and flat roof structures, mounting panels to the support structure.

Additional information:

- stable support of panels for pitched roof and flat roof structures
- width of sockets in the profile prevents rotation of hexagon nuts and bolts (M8 for the top socket and M10 for the lower socket)
- special shape of the profile to increase its strength
- limitation to wind zone 1 and snow zones 1, 2, and 3
- modified upper slot for better installation of CLICK-type clamps
- radii in the mounting slot ensure smooth installation of CLICK-type clamps without excessive force



Aluminium Profile Connector LPAN30 mat.: MC

symbol	catalogue number	weight 1 pc. [kg]	quantity per package [pcs.]
LPAN30	890630	0.03	100

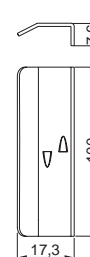

Use:

Screwless connection of aluminium profiles.

Additional information:

- bevelled ends facilitate initial insertion of the connector into the profile
- the shape of the connector provides a very stable profile connection
- stops for the depth of insertion of the fastener into the profile
- made of Magnelis-coated material with very high corrosion resistance
- high strength parameters



A - Assembly of PAL30H32 Aluminium Profile to DUR40E Adjustable Roof Fixing
B - Assembly of LPAN30 Aluminium Profile Connectors to connect PAL30H32 Aluminium profiles

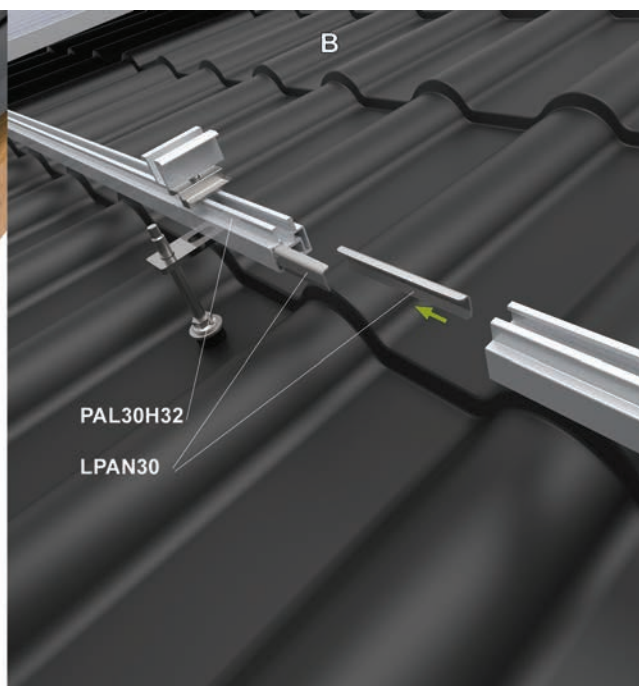

A - aluminium, L - painting in standard RAL colour
MC - steel in Magnelis® coating

Support Channel		CWP40H35...MC	mat.: MC		
symbol	catalogue number	dimension L [mm]	weight 1 pc. [kg]	quantity per package [pcs.]	
Material thickness = 1.5 mm					
CWP40H35/2,2MC	620412	2244	2.87	1	
CWP40H35/3,3MC	620413	3366	4.30	1	

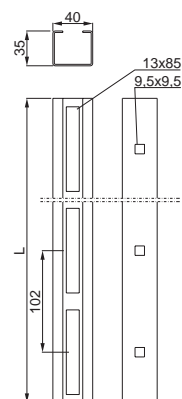

Use:
Support of panels in pitched roof and flat roof structures, mounting panels to the support structure.

Additional information:

- stable support of panels for pitched roof and flat roof structures
- high strength parameters
- 13x85 holes allow for mounting profiles to handles anywhere without drilling
- 9.5 mm square holes in the sides of the channel allow screwing on additional equipment, e.g. cable trays, power optimizers
- possibility to route solar cables and MC4 connectors inside the channel
- low price

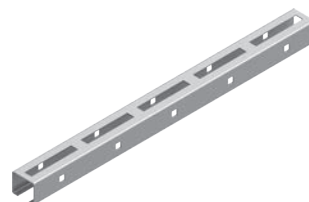

Connector		LC40H35MC	mat.: MC		
symbol	catalogue number	weight 1 pc. [kg]	quantity per package [pcs.]		
Material thickness = 1.5 mm					
LC40H35MC	620414	0.16	100		

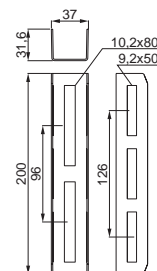

Use:
Connecting channels.

Additional information:

- stable, strong connection of channel sections
- the length of the link increases the adjustment range
- specially designed perforation in the connector allows channel installation anywhere without drilling
- for the assembly use 2 x SGKFM10x20PV Screw Sets

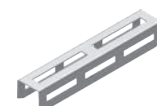

A - Installation of the CWP40H35 ... MC support channel to adjustable roof mounting DUR40E
B - Installation of LC40H35MC couplers to connect CWP40H35 ... MC support channels

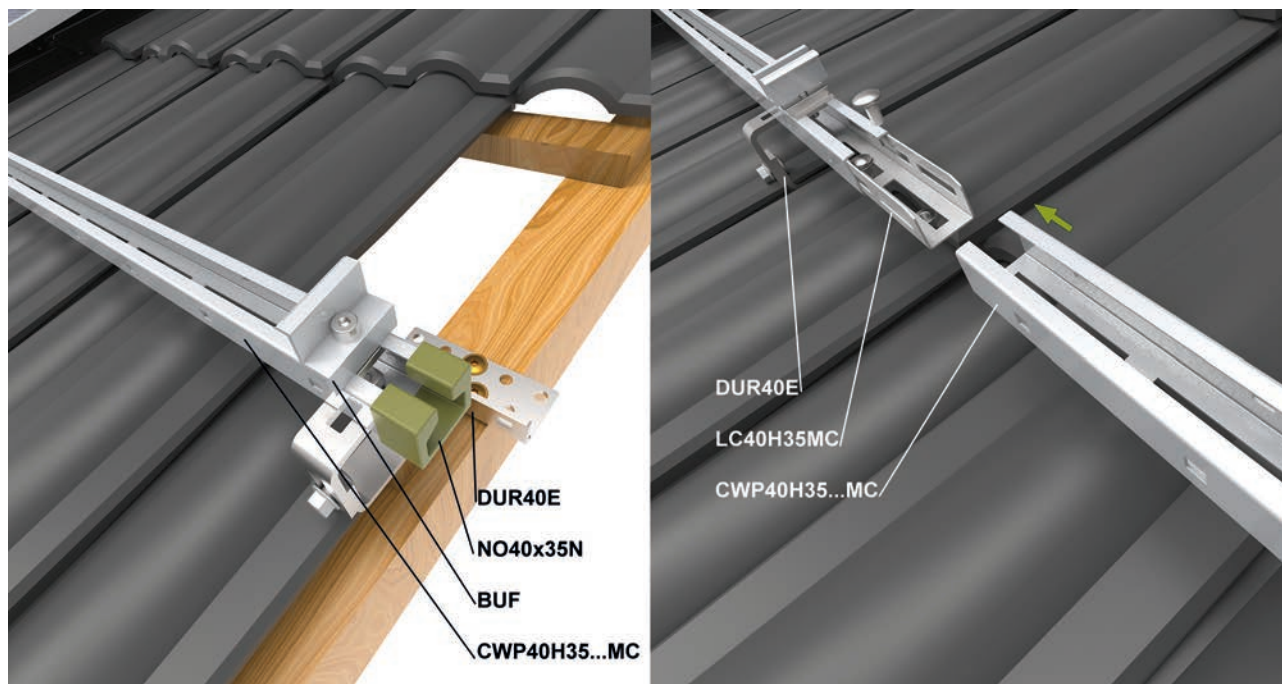



Aluminium mounting rail	SMA...	mat.: A	option: L		
symbol	catalogue number	dimension a/H/L [mm]	weight 1 pc. [kg]	quantity per package [pcs.]	
SMA40/033	890433	114/40/330	0.36	20	
SMA40/04	890440	114/40/400	0.45	20	
SMA40/6	890466	114/40/6050	7.02	5	
SMA70/033	890733	120/70/330	0.47	20	
SMA70/04	890740	120/70/400	0.60	20	
SMA70/6	890766	120/70/6050	10.44	5	
SMA100/033	890133	120/100/330	0.61	20	
SMA100/04	890140	120/100/400	0.80	20	
SMA100/6	890166	120/100/6050	11.20	5	

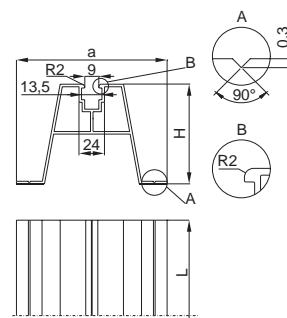

Use:
Mounting PV panels to trapezoidal sheet metal, such as the DS-V6aN structure.

- Additional information:**
- 40 or 70 or 10 mm rail height ensures quick mounting and good ventilation under PV panels
 - special section to increase the strength of the element
 - contact surfaces of the rail with the roof equipped with sealing rubber except SMA.../6
 - special groove (detail A in the figure) allows easy positioning of screws when screwing in
 - modified upper slot for better installation of CLICK-type clamps
 - for the assembly use min. 4 x SMDP6x25E Screws

Aluminium mounting rail	SM...A	mat.: A	option: L		
symbol	catalogue number	dimension L [mm]	weight 1 pc. [kg]	quantity per package [pcs.]	
SM400	890040	400	0.25	50	
SM6500	890046	6500	4.08	5	

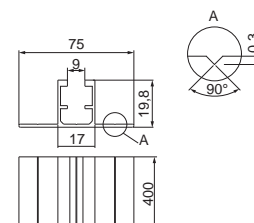

Use:
Mounting PV panels to trapezoidal sheet metal, such as the DS-V6aN structure.

- Additional information:**
- **note:**
the rail is not equipped with sealing rubber
using EPDMW2x40 Cellular Rubber is recommended
 - special groove (detail A in the figure) allows easy positioning of screws when screwing in
 - low height to allow for aesthetic installation of the panels close to the roof surface
 - modified upper slot for better installation of CLICK-type clamps
 - for the assembly use min. 4 x SMDP6x25E Screws

A - Assembly of the SMA70/... Aluminum Mounting Rail to metal tiles sheet
B - Assembly of the SM400 Aluminum Mounting Rail to trapezoidal metal sheet

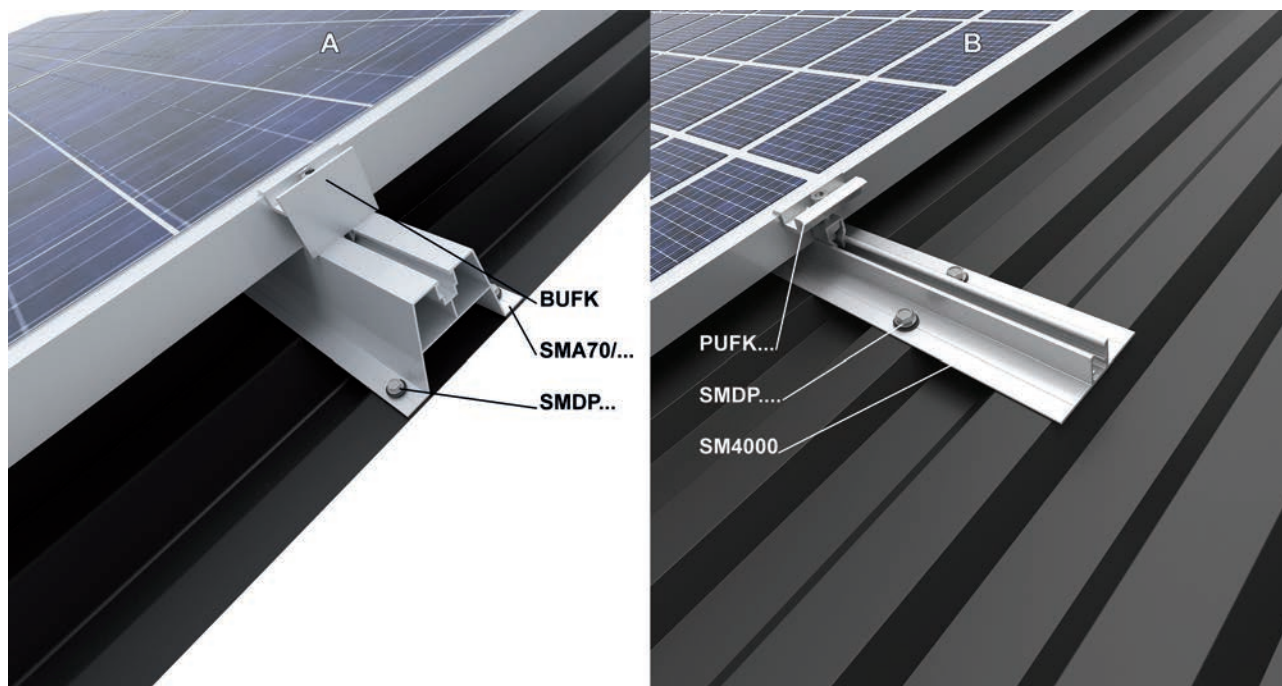

A - aluminium, L - painting in standard RAL colour



Mounting rail connector	LPSMA40	mat.: MC	weight 1 pc. [kg]	quantity per package [pcs.]
symbol	catalogue number			
LPSMA40	892640		0.04	100

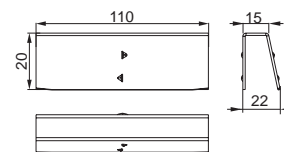

Use:
Screwless connection of aluminium profiles.

Additional information:

- bevelled ends facilitate initial insertion of the connector into the profile
- the shape of the connector provides a very stable profile connection
- stops for the depth of insertion of the fastener into the profile
- made of Magnelis-coated material with very high corrosion resistance
- high strength parameters

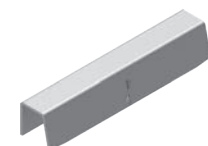

Mounting rail connector	LPSMA70	mat.: MC	weight 1 pc. [kg]	quantity per package [pcs.]
symbol	catalogue number			
LPSMA70	892670		0.06	100

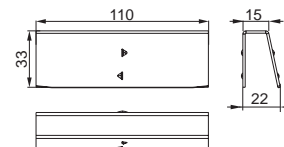

Use:
Screwless connection of aluminium profiles.

Additional information:

- bevelled ends facilitate initial insertion of the connector into the profile
- the shape of the connector provides a very stable profile connection
- stops for the depth of insertion of the fastener into the profile
- high strength parameters
- made of Magnelis-coated material with very high corrosion resistance

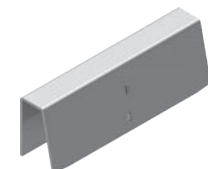

Mounting rail connector	LPSMA	mat.: MC	weight 1 pc. [kg]	quantity per package [pcs.]
symbol	catalogue number			
LPSMA	892620		0.02	100

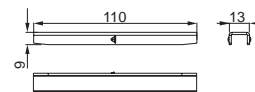

Use:
Screwless connection of aluminium profiles.

Additional information:

- bevelled ends facilitate initial insertion of the connector into the profile
- the shape of the connector provides a very stable profile connection
- stops for the depth of insertion of the fastener into the profile
- made of Magnelis-coated material with very high corrosion resistance
- high strength parameters

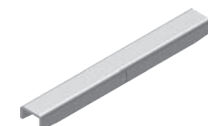

A – Installation of LPSMA70 connectors to join the SMA70/... mounting rail
B – Installation of LPSMA connectors to join the SM400 mounting rail

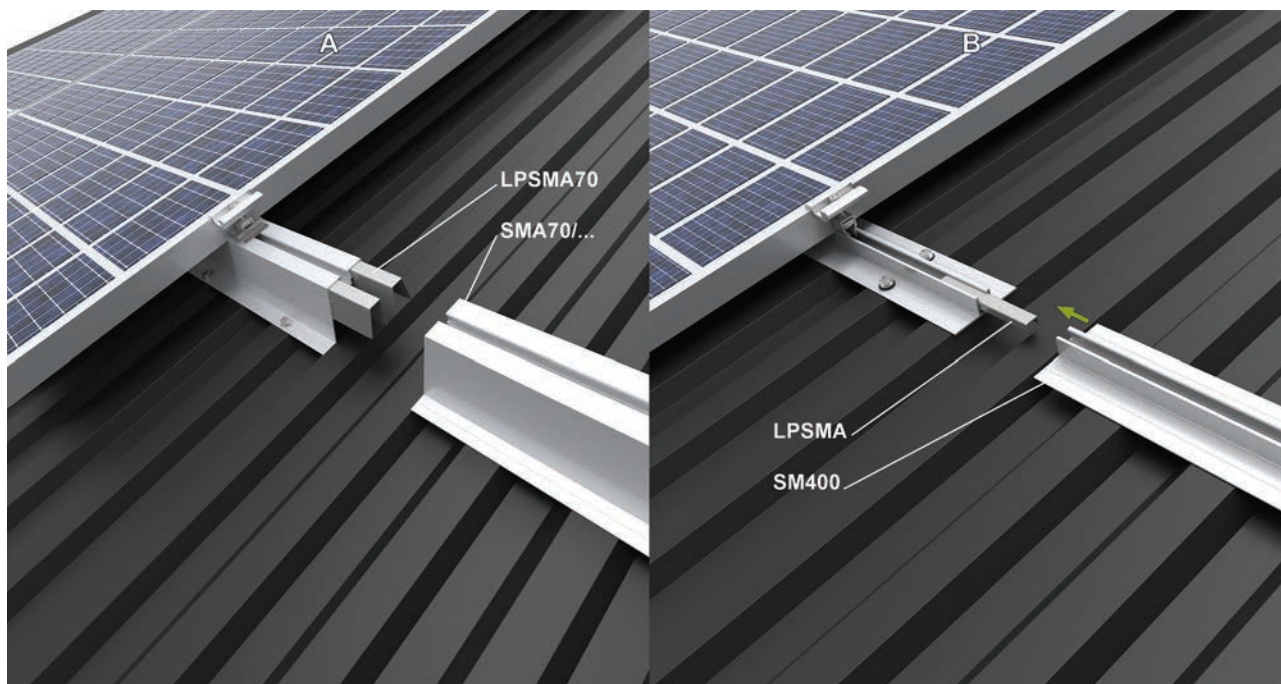

Structures for mounting photovoltaic panels - mounting elements

Middle panel clamp with grounding washer

PUPF mat.: A option: L

symbol	catalogue number	dimension L [mm]	weight 1 pc. [kg]	quantity per package [pcs.]
Material thickness = 3.0 mm				
PUPF	898502	50	0.02	100

N **STM**

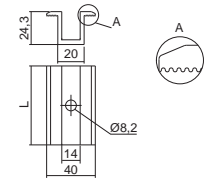

Use:

Mounting PV panels to aluminium profiles, channels and brackets.

Additional information:

- notches to improve grip
- longitudinal grooves at the panel pressure point and at the contact surface between the clamp and the profile increase the stability of the fixing
- special section to increase the strength of the element
- the clamp includes a pressed-in serrated stainless steel washer that ensures electrical continuity between the clamp and the PV panel
- clamps available in 3 lengths — L = 50 mm, 75 mm, 100 mm



Middle panel clamp with grounding washer

PUFEP mat.: A option: L

symbol	catalogue number	dimension L [mm]	weight 1 pc. [kg]	quantity per package [pcs.]
Material thickness = 4.0 mm				
PUFEP	898503	50	0.04	100

N **STM**

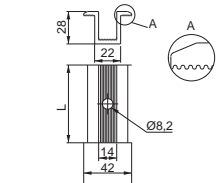

Use:

Mounting PV panels to aluminium profiles, channels and brackets.

Additional information:

- notches to improve grip
- longitudinal grooves at the panel pressure point and at the contact surface between the clamp and the profile increase the stability of the fixing
- special section to increase the strength of the element
- the clamp includes a pressed-in serrated stainless steel washer that ensures electrical continuity between the clamp and the PV panel
- clamps available in 3 lengths — L = 50 mm, 75 mm, 100 mm

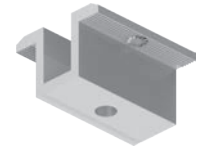

- A - Installing the side bracket with grounding pad BUFP...
- B - Installing the BUFEF... side bracket with grounding pad
- C - Installing the intermediate bracket with the PUPF grounding pad

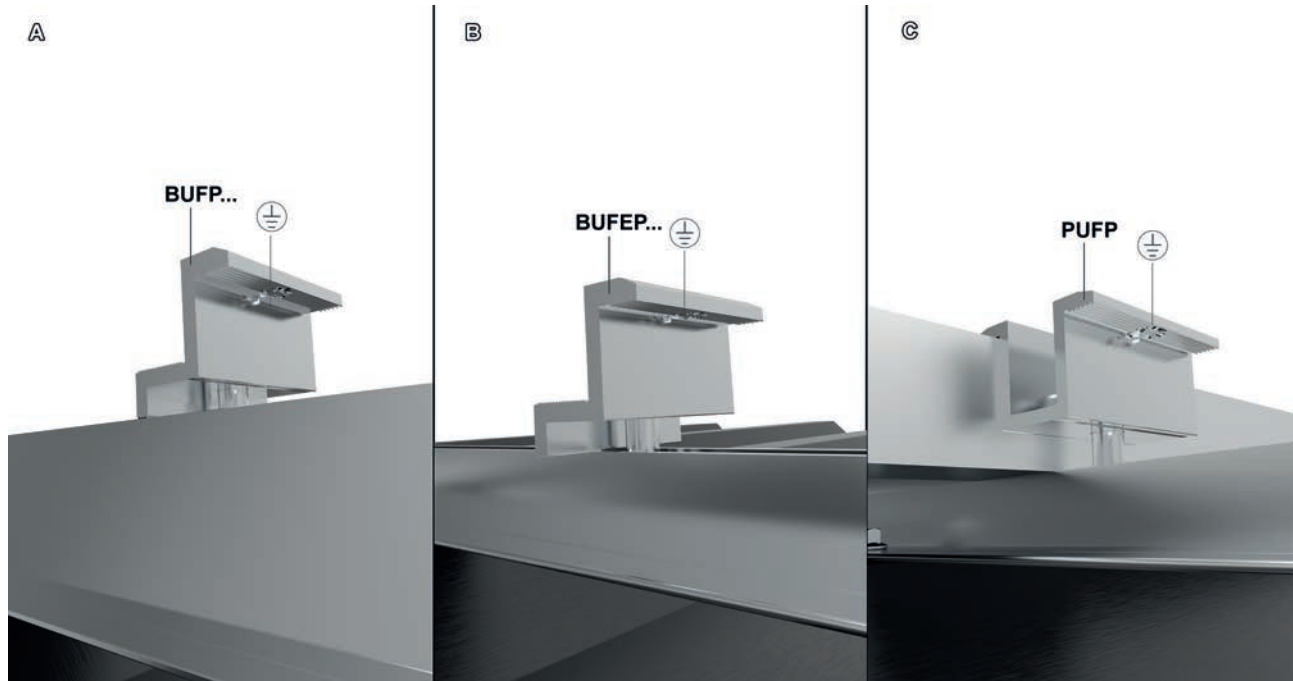

Structures for mounting photovoltaic panels - mounting elements

Middle panel CLICK-clamp with PUFPK grounding washer

mat.: A option: L

symbol	catalogue number	dimension L [mm]	weight 1 pc. [kg]	quantity per package [pcs.]
Material thickness = 3.0 mm				
PUFPK	898500	50	0.04	50

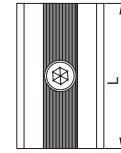
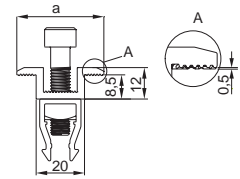

Use:

Mounting PV panels to aluminium profiles, channels and brackets.

Additional information:

- quick and stable mounting
- clamps available in 3 lengths — L = 50 mm, 75 mm, 100 mm
- the clamp includes a pressed-in serrated stainless steel washer that ensures electrical continuity between the clamp and the PV panel
- compatible with mounting on SM... rails, PAL... profiles, UPDMC and UPG...MC clamps, as well as PGTSMC and PGTSWZMC profiles

Middle panel CLICK-clamp with PUFEPK grounding washer

mat.: A option: L

symbol	catalogue number	dimension L [mm]	weight 1 pc. [kg]	quantity per package [pcs.]
Material thickness = 4.0 mm				
PUFEPK	898501	50	0.06	50

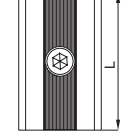
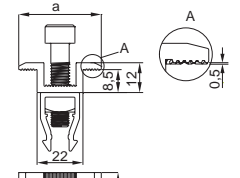

Use:

Mounting PV panels to aluminium profiles, channels and brackets.

Additional information:

- quick and stable mounting
- clamps available in 3 lengths — L = 50 mm, 75 mm, 100 mm
- the clamp includes a pressed-in serrated stainless steel washer that ensures electrical continuity between the clamp and the PV panel
- compatible with mounting on SM... rails, PAL... profiles, UPDMC and UPG...MC clamps, as well as PGTSMC and PGTSWZMC profiles

- A - Installation of the intermediate holder with grounding pad KLIK PUFPK
- B - Installing the side bracket with grounding pad CLICK BUFPK...
- C - Installing the side bracket with grounding pad CLICK BUFPEK...

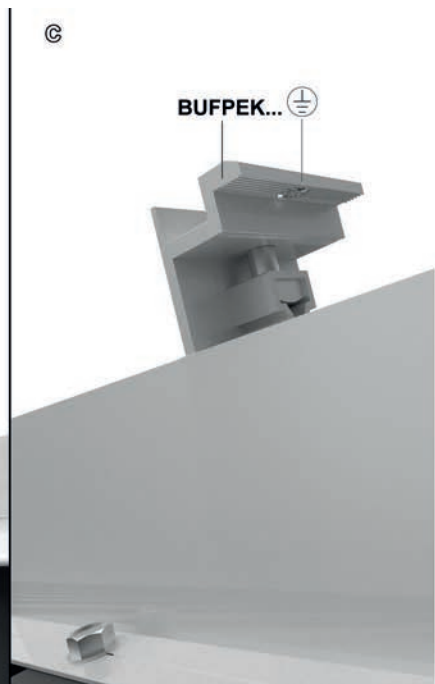
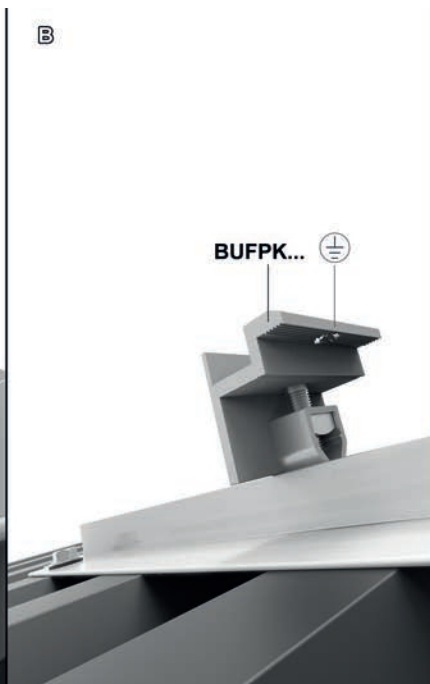
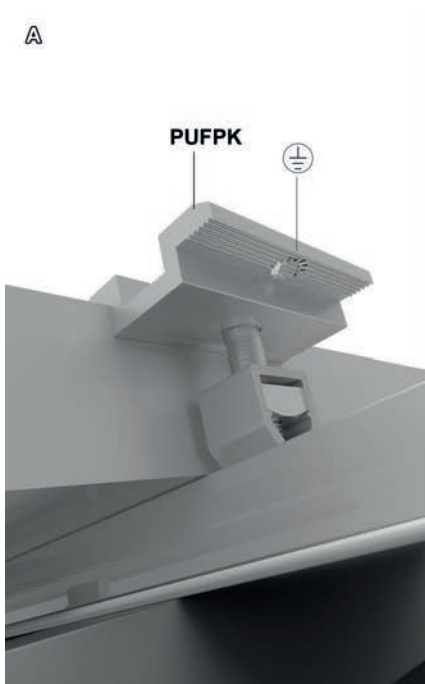

Structures for mounting photovoltaic panels - mounting elements

Side panel CLICK-clamp with grounding washer **BUFPK...** mat.: A option: L

symbol	catalogue number	dimension H/L [mm]	weight 1 pc. [kg]	quantity per package [pcs.]
Material thickness = 3.0 mm				
BUFPK30	898230	30/50	0.04	50
BUFPK35	898235	35/50	0.06	50

Additional information:

- quick and stable mounting
- clamps available in 3 lengths — L = 50 mm, 75 mm, 100 mm
- the clamp includes a pressed-in serrated stainless steel washer that ensures electrical continuity between the clamp and the PV panel
- compatible with mounting on SM... rails, PAL... profiles, UPDMC and UPG...MC clamps, as well as PGTSMC and PGTSWZMC profiles

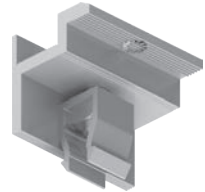
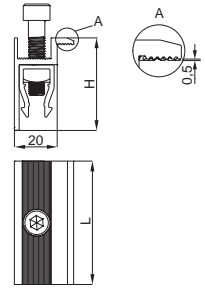

Side panel CLICK-clamp with grounding washer **BUFEPK...** mat.: A option: L

symbol	catalogue number	dimension H/L [mm]	weight 1 pc. [kg]	quantity per package [pcs.]
Material thickness = 4.0 mm				
BUFEPK30	870530	30/50	0.06	50
BUFEPK35	870535	35/50	0.08	50

Additional information:

- quick and stable mounting
- clamps available in 3 lengths — L = 50 mm, 75 mm, 100 mm
- the clamp includes a pressed-in serrated stainless steel washer that ensures electrical continuity between the clamp and the PV panel
- compatible with mounting on SM... rails, PAL... profiles, UPDMC and UPG...MC clamps, as well as PGTSMC and PGTSWZMC profiles

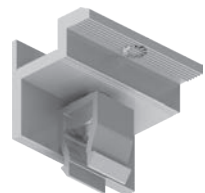
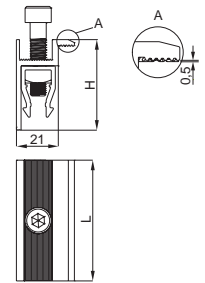

- A - Installation of the intermediate holder with grounding pad KLIK PUFPK
- B - Installing the side bracket with grounding pad CLICK BUFPK...
- C - Installing the side bracket with grounding pad CLICK BUFPEK...

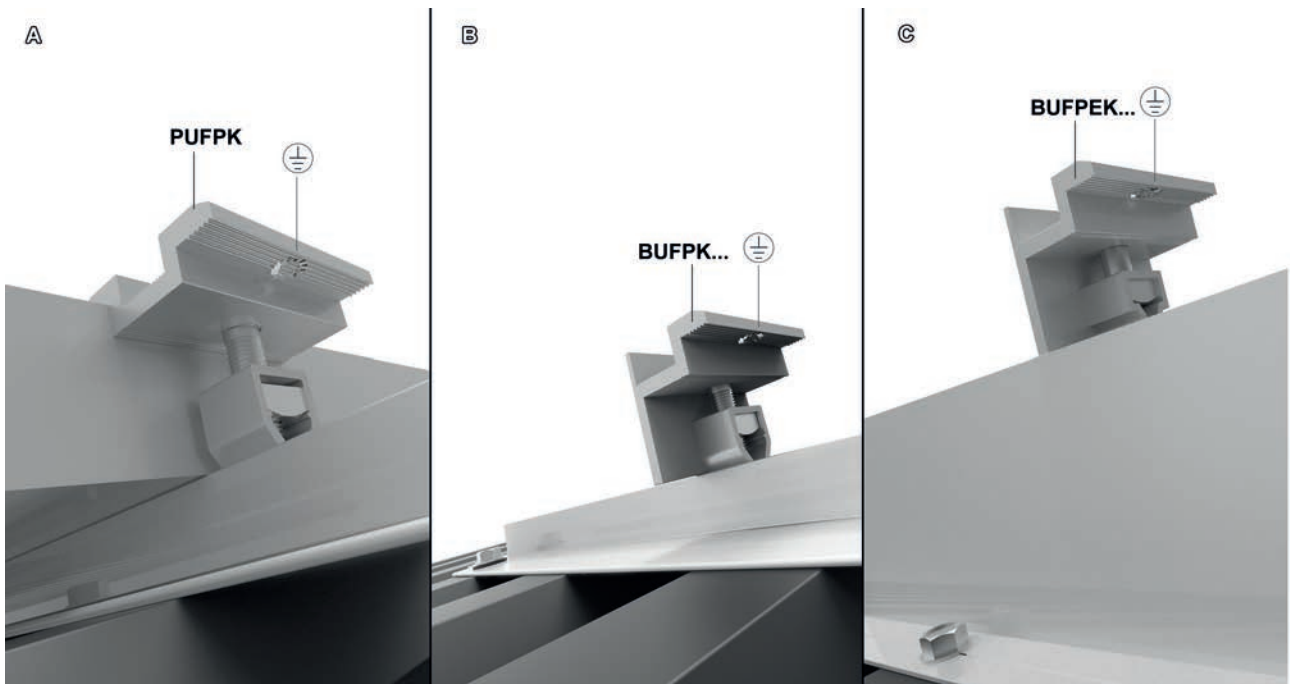

Structures for mounting photovoltaic panels - mounting elements

Middle holder CLICK

PUFK

mat.: A

option: L

symbol	catalogue number	weight 1 pc. [kg]	quantity per package [pcs.]
--------	------------------	-------------------	-----------------------------

STM

Material thickness = 3.0 mm

PUFK	890300	0.04	50
------	--------	------	----

Use:

Mounting PV panels to aluminium profiles, channels and brackets.

Additional information:

- The set includes glue, SAM8... hex bolt, NKWM8E square nut and CLICK clip
- quick and stable mounting

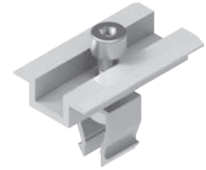
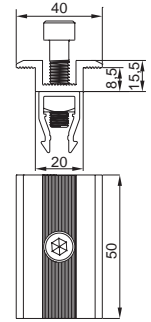

Side holder CLICK

BUFK...

mat.: A

option: L

symbol	catalogue number	dimension H [mm]	weight 1 pc. [kg]	quantity per package [pcs.]
--------	------------------	------------------	-------------------	-----------------------------

STM

Material thickness = 3.0 mm

BUFK30	897430	30	0.04	50
BUFK32	897432	32	0.05	50
BUFK34	897434	34	0.06	50
BUFK35	897435	35	0.06	50
BUFK38	897438	38	0.07	50
BUFK40	897440	40	0.07	50
BUFK42	897442	42	0.07	50
BUFK45	897446	45	0.08	50
BUFK50	897450	50	0.08	50

Use:

Mounting PV panels to aluminium profiles, channels and brackets.

Additional information:

- The set includes glue, SAM8... hex bolt, NKWM8E square nut and CLICK clip
- quick and stable mounting

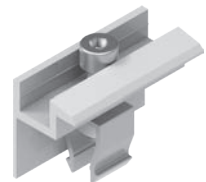
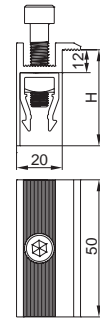

A - Assembly of the PUFK Middle Holder Click to the SM400 Aluminum Mounting Rail

B - Assembly of the UPPMC Middle Holder to the CWC100H50...MC Support Channel in a place with no perforation

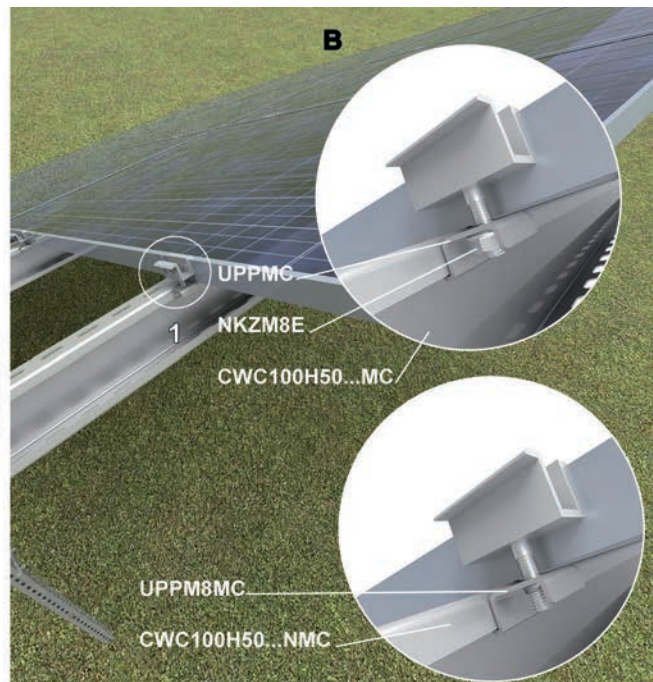
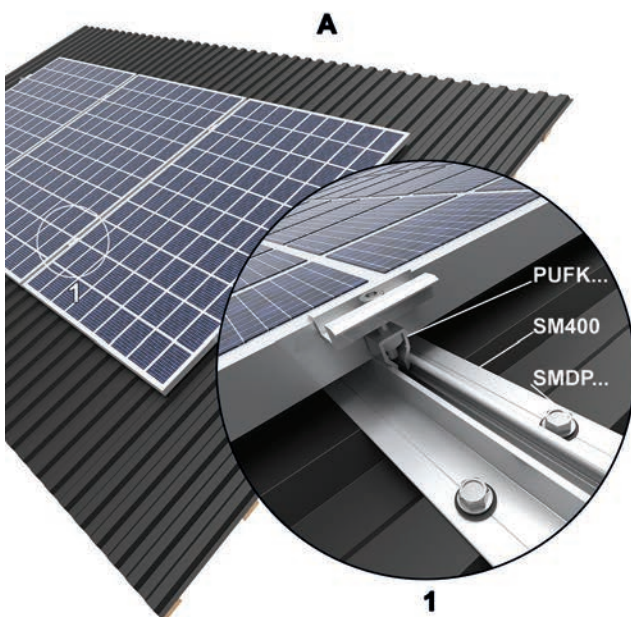

A - aluminium, L - painting in standard RAL colour

Structures for mounting photovoltaic panels - mounting elements

Middle holder CLICK

PUFEK...

mat.: A

option: L

symbol	catalogue number	dimension L [mm]	weight 1 pc. [kg]	quantity per package [pcs.]
--------	------------------	------------------	-------------------	-----------------------------

STM

Material thickness = 4.0 mm

PUFEK50	897315	50	0.04	100
PUFEK75	897316	75	0.05	100
PUFEK100	897317	100	0.06	100

Use:

Mounting PV panels to aluminium profiles, channels and brackets.

Additional information:

- The set includes glue, SAM8... hex bolt, NKWM8E square nut and CLICK clip
- quick and stable mounting

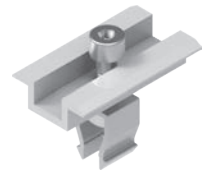
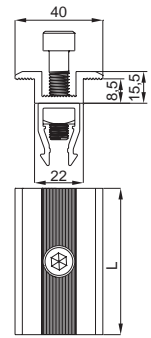

Side holder CLICK

BUFEK...

mat.: A

option: L

symbol	catalogue number	dimension L/H [mm]	weight 1 pc. [kg]	quantity per package [pcs.]
--------	------------------	--------------------	-------------------	-----------------------------

STM

Material thickness = 4.0 mm

BUFEK30/50	888530	50/30	0.04	50
BUFEK32/50	888532	50/32	0.05	50
BUFEK35/50	888535	50/35	0.06	50
BUFEK30/75	888730	75/30	0.05	50
BUFEK32/75	888732	75/32	0.06	50
BUFEK35/75	888735	75/35	0.07	50
BUFEK30/100	888130	100/30	0.06	50
BUFEK32/100	888132	100/32	0.07	50
BUFEK35/100	888135	100/35	0.08	50

Use:

Mounting PV panels to aluminium profiles, channels and brackets.

Additional information:

- The set includes glue, SAM8... hex bolt, NKWM8E square nut and CLICK clip
- quick and stable mounting

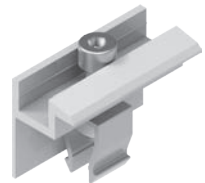
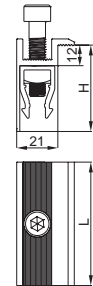

Mounting the CLICK PUFEK middle holder... to the SM400 aluminum rail

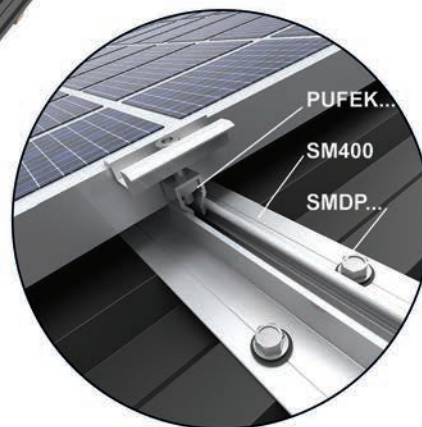
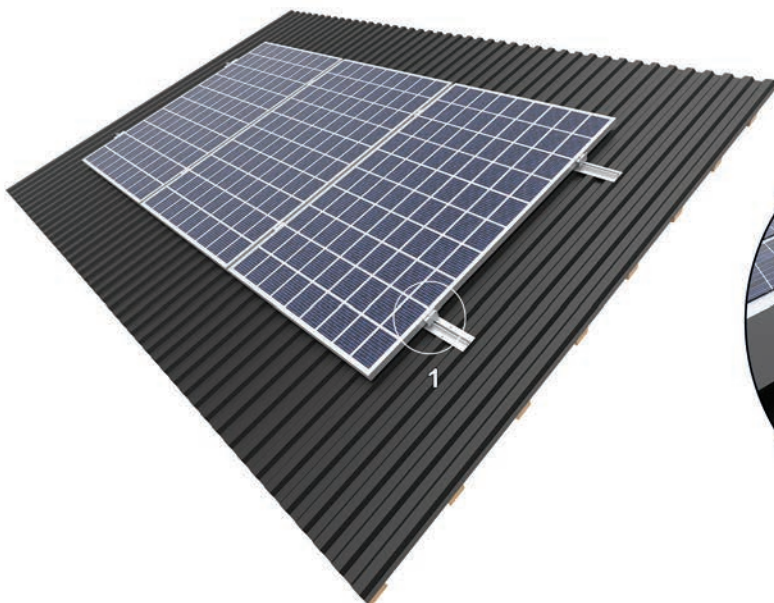

1

Structures for mounting photovoltaic panels - mounting elements

Middle holder		PUFE...	mat.: A	option: L	
symbol	catalogue number	dimension L [mm]	weight 1 pc. [kg]	quantity per package [pcs.]	STM
Material thickness = 4.0 mm					
PUFE50	897415	50	0.02	100	
PUFE75	897416	75	0.03	100	
PUFE100	897417	100	0.04	100	

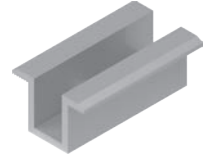
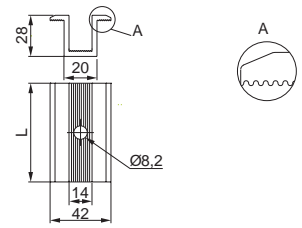

Use:

Mounting PV panels to aluminium profiles, channels and brackets.

Additional information:

- notches to improve grip
- longitudinal grooves at the panel pressure point and at the contact surface between the clamp and the profile increase the stability of the fixing
- special section to increase the strength of the element

Side Holder		BUFE...	mat.: A	option: L	
symbol	catalogue number	dimension L/H [mm]	weight 1 pc. [kg]	quantity per package [pcs.]	STM
Material thickness = 4.0 mm					
BUFE30/50	858530	50/30	0.02	100	
BUFE32/50	858532	50/32	0.02	100	
BUFE35/50	858535	50/35	0.02	100	
BUFE30/75	858730	75/30	0.03	100	
BUFE32/75	858732	75/32	0.03	100	
BUFE35/75	858735	75/35	0.03	100	
BUFE30/100	858130	100/30	0.04	100	
BUFE32/100	858132	100/32	0.04	100	
BUFE35/100	858135	100/35	0.04	100	

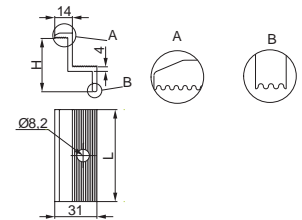

Use:

Mounting PV panels to aluminium profiles, channels and brackets.

Additional information:

- notches to improve grip
- longitudinal grooves at the panel pressure point and at the contact surface between the clamp and the profile increase the stability of the fixing
- special section to increase the strength of the element

- 1 - Installation of the side bracket BUFE... to the PAL aluminum profile
- 2 - Installation of the middle bracket PUFE with the PAL40H40 aluminum profile

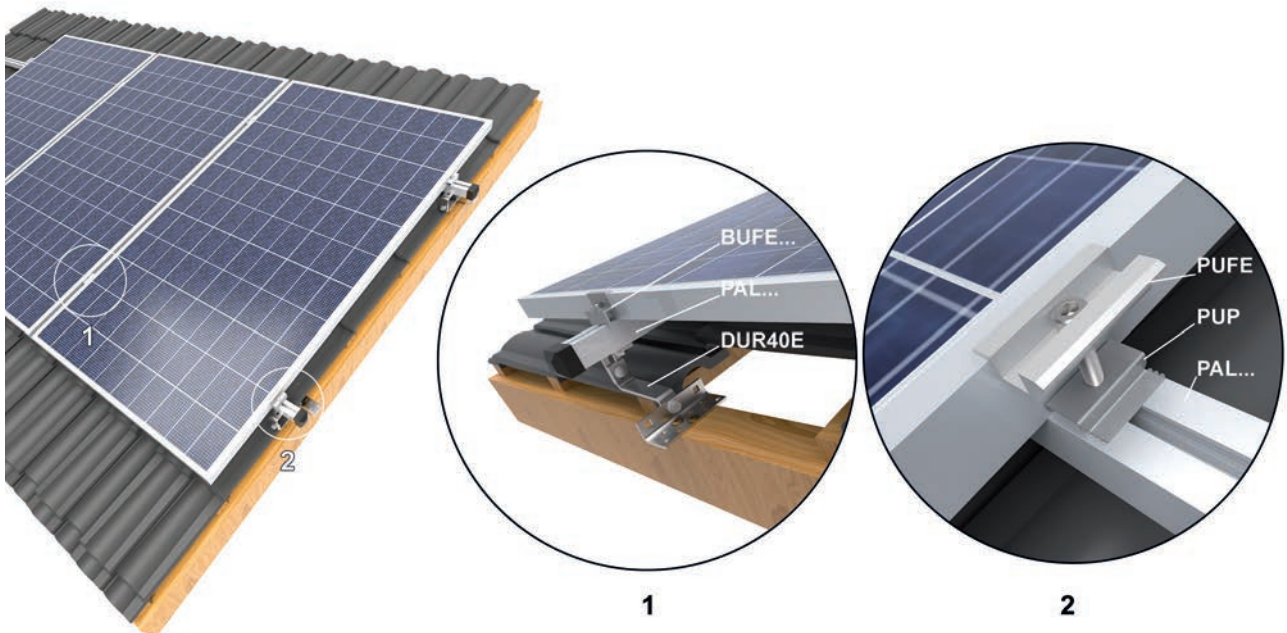

Middle holder for free-standing structures UPP...MC mat.: MC

symbol	catalogue number	weight 1 pc. [kg]	quantity per package [pcs.]	min. order [pcs.]	STM ST
UPPMC	897301	0.03	100	100	ST
UPPM8MC	897311	0.03	100	100	STM

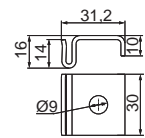

Use:

Mounting PV panels to channels without drilling holes in the profile, if the mounting points of the clamps do not coincide with the factory perforation of the profile

Additional information:

- made of Magnelis-coated material with very high corrosion resistance
- allows mounting without drilling
- smooth adjustment of position
- mounting on the edge of the profile up to a thickness of 2.0 mm
- threaded M8 hole in the UPPM8MC option
- For the Installation of UPPMC use 1 x SAM8x...E Screw and NKZM8E Nut
- For the Installation of UPPM8MC use 1 x SAM8x...E Screw

A - Assembly of the PUFK Middle Holder Click to the SM400 Aluminum Mounting Rail
 B - Assembly of the UPPMC Middle Holder to the CWC100H50...MC Support Channel in a place with no perforation

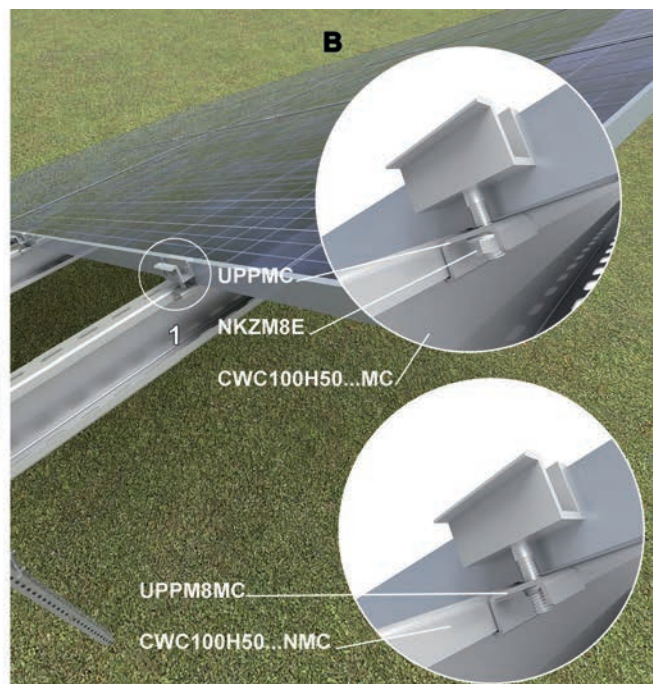
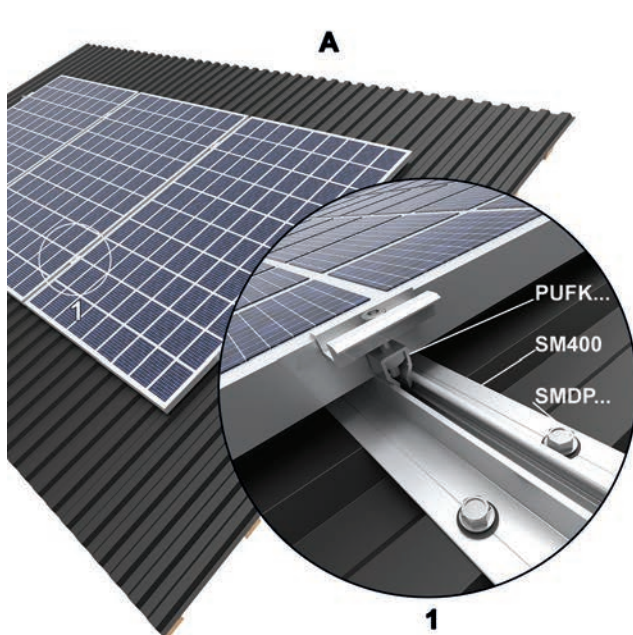

MC - steel in Magnelis® coating

Structures for mounting photovoltaic panels - mounting elements

End panel bolt adapter	ASPKMC	mat.: MC		
symbol	catalogue number	weight 1 pc. [kg]	quantity per package [pcs.]	
ASPKMC	895859	0.07	30	

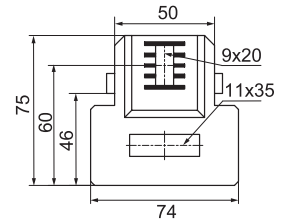

Use:
Mounting panels using holes in the lower frame shelf instead of clamps.

Additional information:

- stable mounting directly with screws, no clamps needed
- thanks to panel mounting using frame holes, there is no need to check permitted mounting zones on the panel frame
- for mounting to the structure, use 1 set of SGKFM10x20
- for panel mounting, use 1 set of SSZ8x14F + PP8F

Middle panel bolt adapter	ASPPMC	mat.: MC		
symbol	catalogue number	weight 1 pc. [kg]	quantity per package [pcs.]	
ASPPMC	895858	0.10	20	

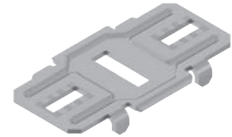
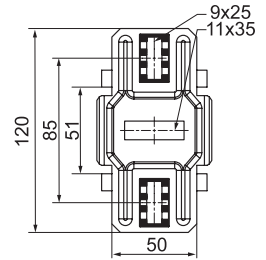

Use:
Mounting panels using holes in the lower frame shelf instead of clamps.

Additional information:

- stable mounting directly with screws, no clamps needed
- thanks to panel mounting using frame holes, there is no need to check permitted mounting zones on the panel frame
- for mounting to the structure, use 1 set of SGKFM10x20
- for panel mounting, use 1 set of SSZ8x14F + PP8F

Middle panel bolt adapter	ASPGMC	mat.: MC		
symbol	catalogue number	weight 1 pc. [kg]	quantity per package [pcs.]	
ASPGMC	895855	0.14	20	

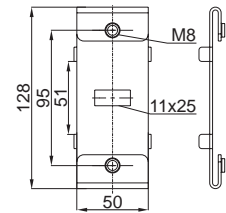

Use:
Mounting panels using holes in the lower frame shelf instead of clamps.

Additional information:

- stable mounting directly with screws, no clamps needed
- thanks to panel mounting using frame holes, there is no need to check permitted mounting zones on the panel frame
- for mounting to the structure, use 1 set of SGKFM10x20
- for panel mounting, use 1 set of SSZ8x14F + PP8F

Installation of the end panel bolt adapter ASPKMC, middle panel bolt adapter ASPPMC, and threaded adapter ASPGMC

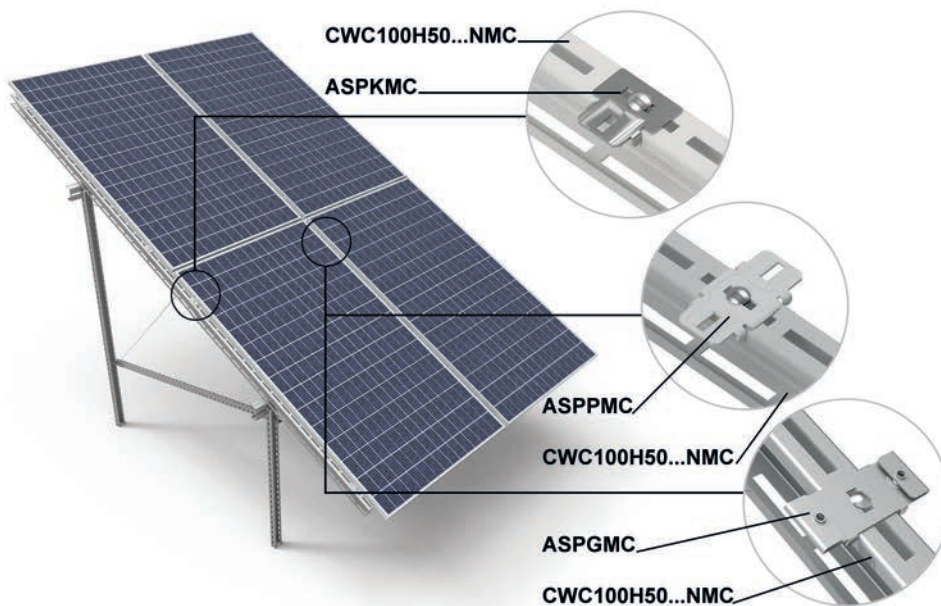



Side adapter for panel mounting bracket ADBIBUFMC

mat.: MC



symbol	catalogue number	weight 1 pc. [kg]	quantity per package [pcs.]
ADBIBUFMC	895857	0.12	30

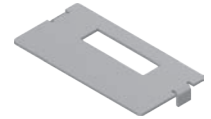
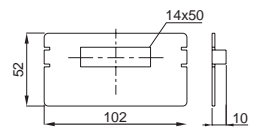

Use:

Installation between the side clamp and the load-bearing profile in free-standing structures.

Additional information:

- increased contact surface area between the panel and the structure
- increased stability of panel mounting
- increased adjustment options for panel positioning

Middle adapter for panel mounting bracket ADBIPUFMC

mat.: MC



symbol	catalogue number	weight 1 pc. [kg]	quantity per package [pcs.]
ADBIPUFMC	895856	0.16	20

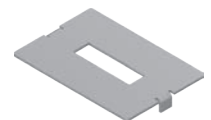
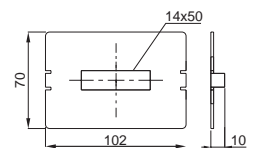

Use:

Installation between the side clamp and the load-bearing profile in free-standing structures.

Additional information:

- increased contact surface area between the panel and the structure
- increased stability of panel mounting
- increased adjustment options for panel positioning

Installation of the side panel bracket adapter ADBIBUFMC and middle panel bracket adapter ADBIPUFMC

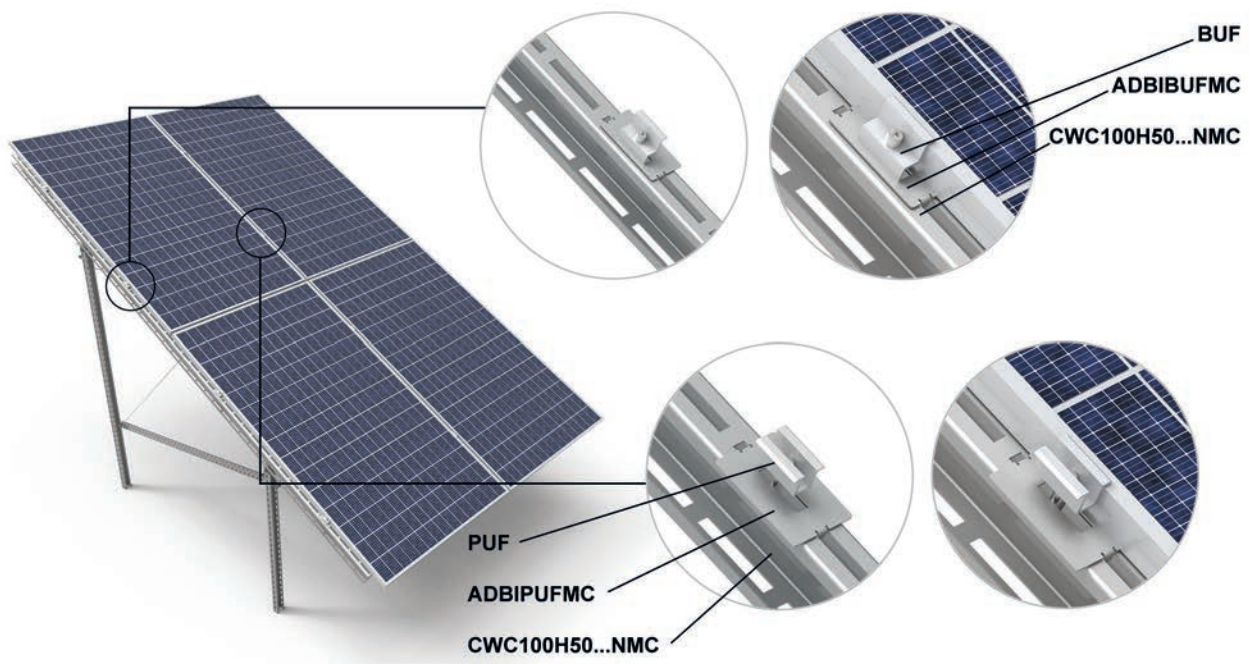

Structures for mounting photovoltaic panels - mounting elements

Grounding Washer	PUAP	mat.: E		
symbol	catalogue number	weight 1 pc. [kg]	quantity per package [pcs.]	
PUAP	897306	0.05	100	

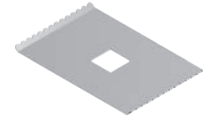
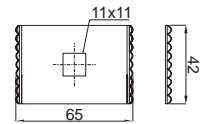

Use:
Installation at the contact surface between the panel frames and the supporting system to ensure electrical continuity

Additional information:

- no need to use earth connections in form of cables
- allows the use of standard middle panel holders
- reduction of installation time
- security enhancement
- ensured electrical continuity
- does not damage the panel frame

Grounding Washer	PUP	mat.: E		
symbol	catalogue number	weight 1 pc. [kg]	quantity per package [pcs.]	
PUP	897303	0.05	100	

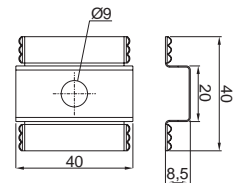

Use:
Installation at the contact surface between the panel frames and the supporting system to ensure electrical continuity

Additional information:

- no need to use earth connections in form of cables
- allows the use of standard middle panel holders
- reduction of installation time
- security enhancement
- ensured electrical continuity
- does not damage the panel frame

- 1 - Assembly of PUP Grounding Washer with PUF Middle Holder and PAL40H40 Aluminum Profile
- 2 - Assembly of PUPK Grounding Washer with PUFK Middle Holder Click and PAL40H40 Aluminum Profile



Structures for mounting photovoltaic panels - mounting elements

Grounding Washer	PUPL	mat.: E	quantity per package [pcs.]
symbol	catalogue number	weight 1 pc. [kg]	
PUPL	897305	0.06	100

N STM

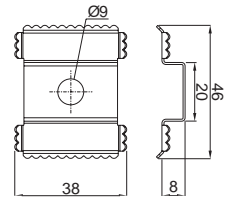

Use:
Installation at the contact points between the powder-coated supporting structure and the panel frames to ensure electrical continuity.

Additional information:

- no need to use earth connections in form of cables
- allows the use of standard middle panel holders
- reduction of installation time
- security enhancement
- ensured electrical continuity
- washers do not damage panel frames thanks to the deformable serrated section
- does not damage the panel frame

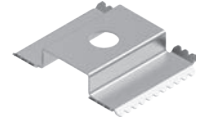

Grounding Washer	PUPK	mat.: E	quantity per package [pcs.]
symbol	catalogue number	weight 1 pc. [kg]	
PUPK	897304	0.05	100

STM

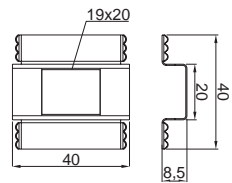

Use:
Installation at the contact surface between the panel frames and the supporting system to ensure electrical continuity

Additional information:

- no need to use earth connections in form of cables
- allows the use of CLICK middle panel holders
- reduction of installation time
- security enhancement
- ensured electrical continuity
- does not damage the panel frame

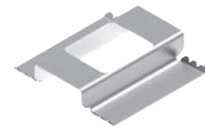

- 1 - Assembly of PUP Grounding Washer with PUF Middle Holder and PAL40H40 Aluminum Profile
- 2 - Assembly of PUPK Grounding Washer with PUFK Middle Holder Click and PAL40H40 Aluminum Profile

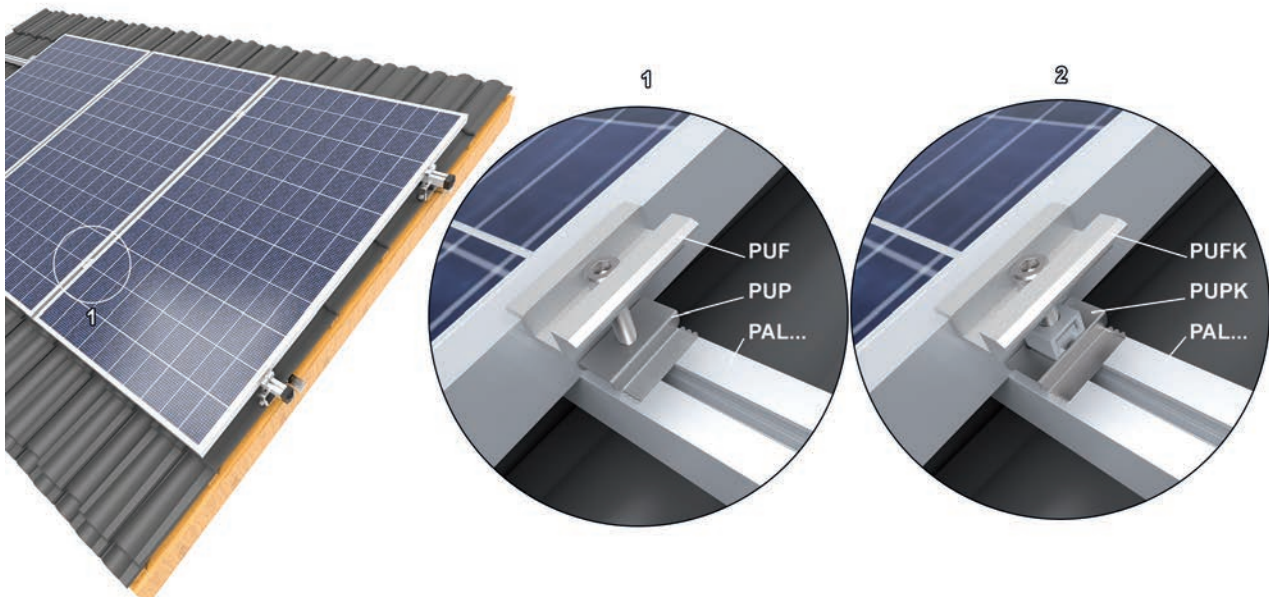



Mounting structures for the Installation of photovoltaic panels - support elements

Profile	BDFCH100...NMC		mat.: MC		
symbol	catalogue number	dimension L [mm]	weight 1 pc. [kg]	quantity per package [pcs.]	STM
Material thickness = 2.0 mm					
BDFCH100/2,75NMC	863725	2754	6.40	1	
BDFCH100/3,2NMC	863132	3164	7.35	1	

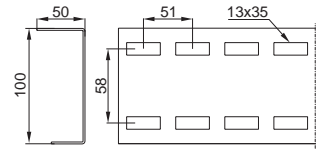

Use:
Profile for determining the inclination angle of freestanding structures

Additional information:

- extended perforation in the upper part allows for the Installation of panels of various dimensions without the need to drill additional holes in the profile
- dense and enlarged perforation on the side increases the possibility of adjusting the angle
- perforation in the lower part allows the bracing profiles to be screwed on without the need to use additional elements
- use SGKFM10x20PV + PW10F bolts for mounting

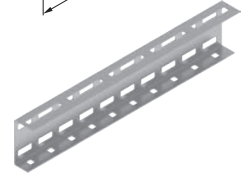
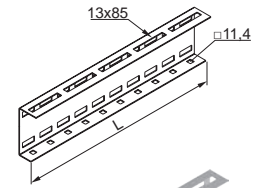

Profile	BDFCH120...NMC		mat.: MC				
symbol	catalogue number	dimension L [mm]	weight 1 pc. [kg]	quantity per package [pcs.]	min. order [pcs.]	STM	ST
Material thickness = 2.0 mm							
BDFCH120/3,6NMC	863335	3570	10.68	1	1	STM	
BDFCH120/4,2NMC	863342	4386	12.88	1	1	STM	
BDFCH120/4,4NMC	863343	4386	13.12	1	1	STM	
BDFCH120/4,8NMC	863347	4794	14.44	1	50	ST	
BDFCH120/5,4NMC	863354	5406	16.17	1	1	STM	

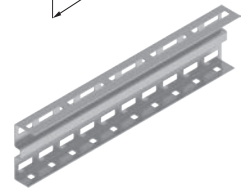
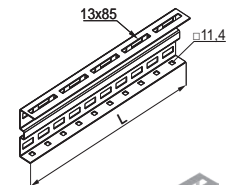
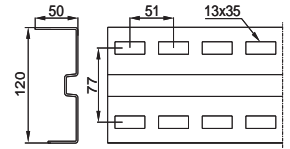

Profile	BDFTH120...NMC		mat.: MC				
symbol	catalogue number	dimension L [mm]	weight 1 pc. [kg]	quantity per package [pcs.]	min. order [pcs.]	STM	ST
Material thickness = 3.0 mm							
BDFTH120/6NMC	863461	6018	25.98	1	50	ST	
BDFTH120/6,4NMC	863464	6426	27.74	1	50	ST	
BDFTH120/6,8NMC	863468	6834	29.50	1	50	STM	

Use:
Profile for determining the inclination angle of freestanding structures

Additional information:

- extended perforation in the upper part allows for the Installation of panels of various dimensions without the need to drill additional holes in the profile
- dense and enlarged perforation on the side increases the possibility of adjusting the angle
- perforation in the lower part allows the bracing profiles to be screwed on without the need to use additional elements
- use SGKFM10x20PV + PW10F bolts for mounting
- quick Installation of BDF...H120 angled profiles with CWC100H50 channels (purlins) thanks to the extension of the upper part of the angled profiles up to 50 mm and shifting of the holes, which enables a convenient approach from below with a socket wrench and a screw gun

Assembly of the BDF...H...NMC Profile with the CWT70H50...NMC Support Channel, which create a table for PV panels

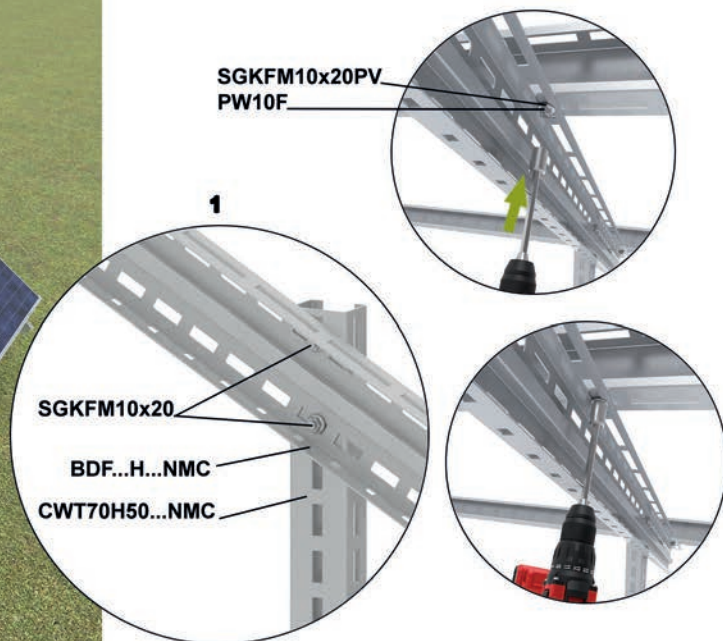
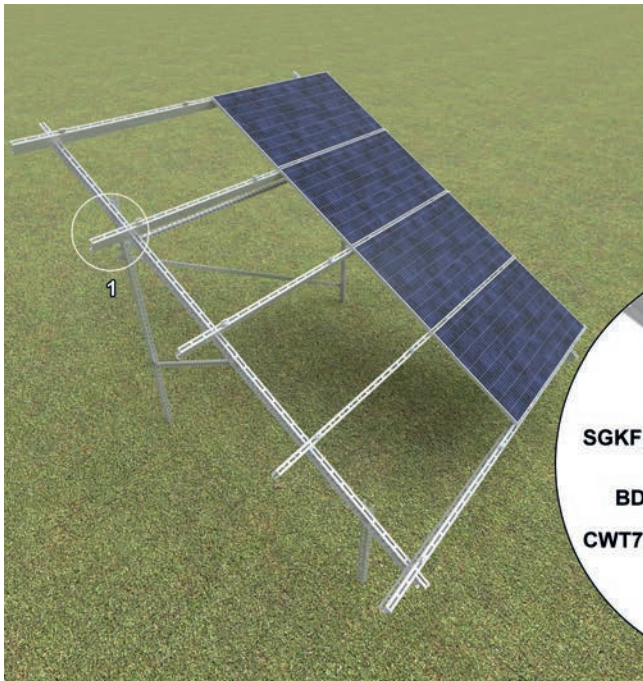

Support Channel CWC100H50...NMC mat.: MC

symbol	catalogue number	dimension L [mm]	weight 1 pc. [kg]	quantity per package [pcs.]
Material thickness = 2.0 mm				
CWC100H50/3,3NMC	867633	3264	9.96	4
CWC100H50/4,4NMC	867644	4386	13.40	4
CWC100H50/6,6NMC	867566	6630	20.30	4

STM

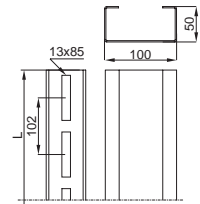

Use:

Direct support of panels and mounting of panel fixing holders

Additional information:

- extended perforation in the upper part allows for the Installation of panels of various dimensions without the need to drill additional holes in the profile
- extended perforation allows for the use of quick fit channel nuts
- identical size of perforation in both walls allows assembly in any position
- use SGKFM10x20PV + PW10F bolts for mounting



Channel connector LCTW100H50MC mat.: MC

symbol	catalogue number	weight 1 pc. [kg]	quantity per package [pcs.]
Material thickness = 2.0 mm			
LCTW100H50MC	856105	0.53	10

N STM

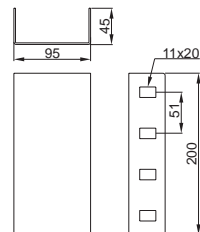

Use:

Connecting channels.

Additional information:

- mounting from the inside of CWC100H50...NMC channels does not cause any collision with a panel placed on the external side of the channel
- installation of screws only in one wall
- for installation, use:
 - 4 sets of SGKFM10x20PV for the W-H4G2 free standing system
 - 8 sets of SGKFM10x20PV for the W-V2G2 free standing system



1 - Connecting CWC100H50...NMC Support Channels with LKTT45H70NMC Channel Connectors

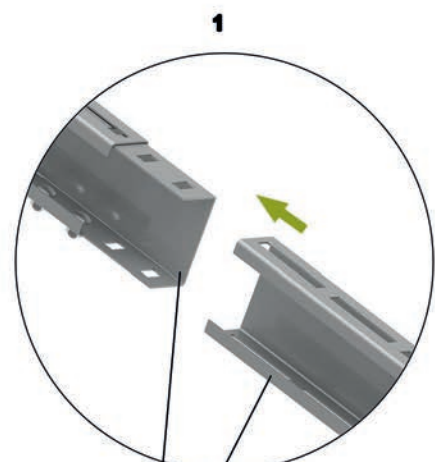
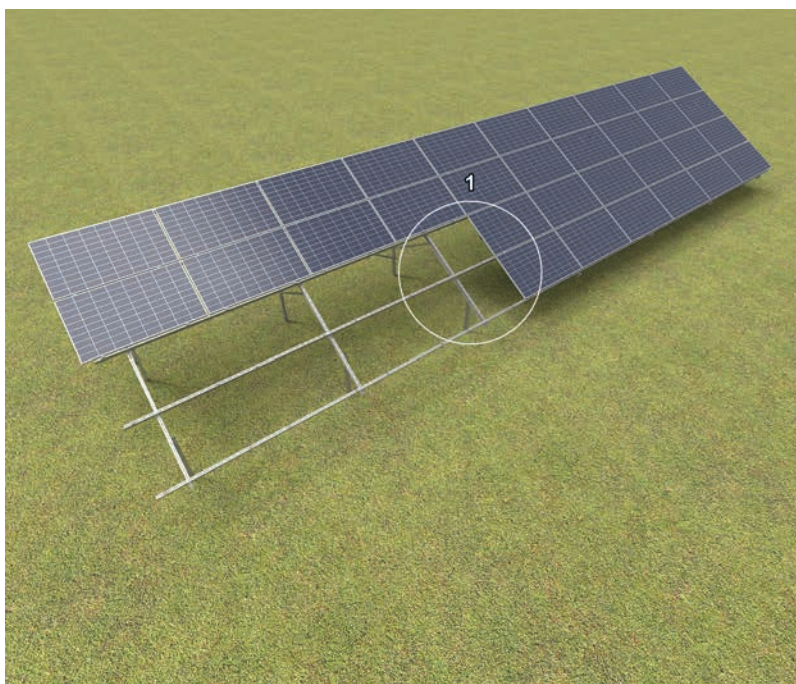

LCTW100H50MC

CWC100H50...NMC

Support Channel

CWCR100H50...MC mat.: MC

symbol	catalogue number	dimension L [mm]	weight 1 pc. [kg]	quantity per package [pcs.]	min. order [pcs.]
--------	------------------	------------------	-------------------	-----------------------------	-------------------

N STM
ST

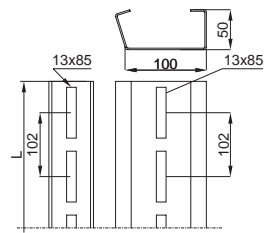

Material thickness = 2.0 mm

CWCR100H50/3,3MC	881533	3264	9.52	4	4	STM
CWCR100H50/4,4MC	881544	4386	12.80	4	4	STM
CWCR100H50/6,6MC	881566	6630	19.40	4	50	ST

Use:

Load-bearing structure element - vertical support posts for free-standing structures.

Additional information:

- extended perforation in the upper part allows for the Installation of panels of various dimensions without the need to drill additional holes in the profile
- extended perforation allows for the use of quick fit channel nuts
- one side bent at an obtuse angle to provide mounting 25 degree angle without the need for additional assembly elements
- use SGKFM10x20PV + PW10F bolts for mounting

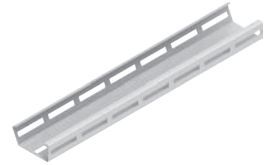

Channel connector

LCWR100H50MC mat.: MC

symbol	catalogue number	weight 1 pc. [kg]	quantity per package [pcs.]
--------	------------------	-------------------	-----------------------------

N STM

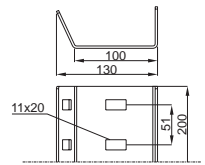

Material thickness = 2.0 mm

LCWR100H50MC	856106	0.54	10
---------------------	---------------	------	----

Use:

Connecting profiles.

Additional information:

- internal mounting in the CWCR100H50...MC channel does not cause interference with profiles tightened from the outside
- for the assembly use 12 x SGKFM10x20PV Screw Sets



Protective cap

NOW100x50SR mat.: PE

symbol	catalogue number	quantity per package [pcs.]
--------	------------------	-----------------------------

N STM

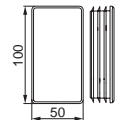

NOW100x50SR	890504	100
--------------------	---------------	-----

Use:

CWC100H50 channel capping...

Additional information:

- improved visual aspect of PV installations
- improving the safety of installers during installation and users after installation



1 - Installation of the reinforced C-channel CWCR100H50 ...MC with reinforced C-channel CWT70H50 ... NMC

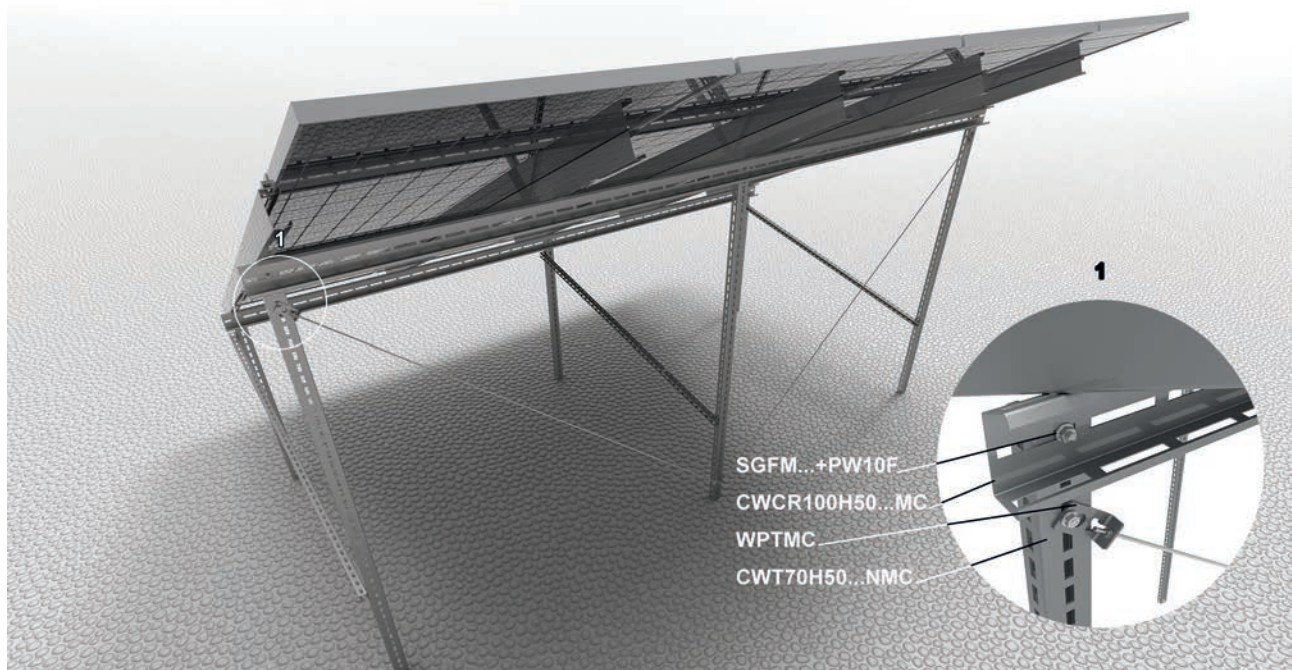

Channel	CT70H50...NMC		mat.: MC			
symbol	catalogue number	dimension L [mm]	weight 1 pc. [kg]	quantity per package [pcs.]	min. order [pcs.]	STM ST
Material thickness = 3.0 mm						
CT70H50/1NMC	864510	1020	3.13	4	50	ST
CT70H50/2NMC	864520	1989	6.26	4	1	STM
CT70H50/3NMC	864530	3009	9.45	4	1	STM
CT70H50/4NMC	864540	3978	12.50	4	1	STM

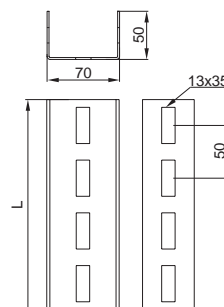

Use:

Load-bearing structure element - vertical support posts for free-standing structures.

Additional information:

- dense perforation enables the levelling of unevenness created during the assembly of the structure in inhomogeneous ground and enables the assembly of the structure with a slightly changed angle of inclination
- enlarged and condensed perforation matched to the BDFCH profiles, so as to enable Installation of structure within the range of 20-35 degrees of inclination of the panels in relation to the ground
- possibility of manufacturing solid channels with perforation only at bolt connection points

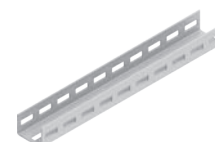

Support Channel	CWT70H50...NMC		mat.: MC			
symbol	catalogue number	dimension L [mm]	weight 1 pc. [kg]	quantity per package [pcs.]	min. order [pcs.]	STM ST
Material thickness = 3.0 mm						
CWT70H50/1NMC	867810	1020	3.67	4	50	ST
CWT70H50/2NMC	867820	1989	7.21	4	1	STM
CWT70H50/2,4NMC	867824	2397	8.81	4	50	ST
CWT70H50/3NMC	867830	3009	11.00	4	1	STM
CWT70H50/3,2NMC	867832	3213	11.80	4	1	STM
CWT70H50/3,4NMC	867834	3413	12.50	4	1	STM
CWT70H50/4,4NMC	867844	4386	16.10	4	1	STM

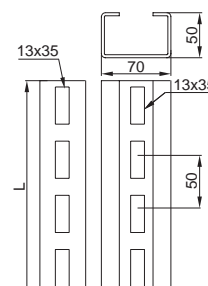

Use:

Load-bearing structure element - vertical support posts for free-standing structures.

Additional information:

- increased tolerance of depth of insertion of support posts into the ground and easier levelling of panels due to extension of holes to 35 mm
- enlarged and condensed perforation matched to the BDFCH profiles, so as to enable Installation of structure within the range of 20-35 degrees of inclination of the panels in relation to the ground
- possibility of manufacturing solid channels with perforation only at bolt connection points

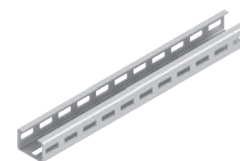

1 - Assembly of the BDFCH120...NMC Profile with the CWT70H50...NMC Support Channel

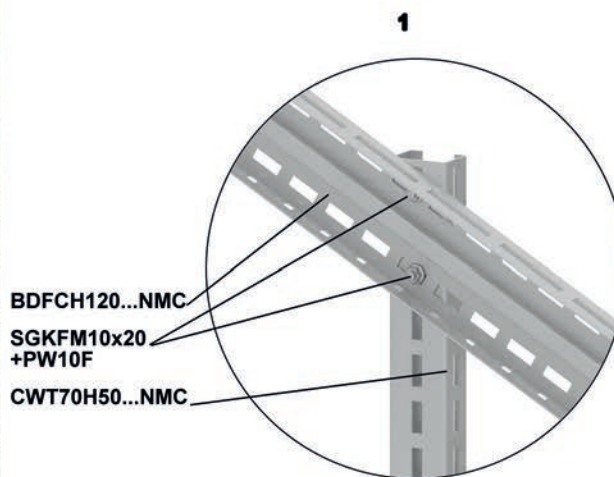
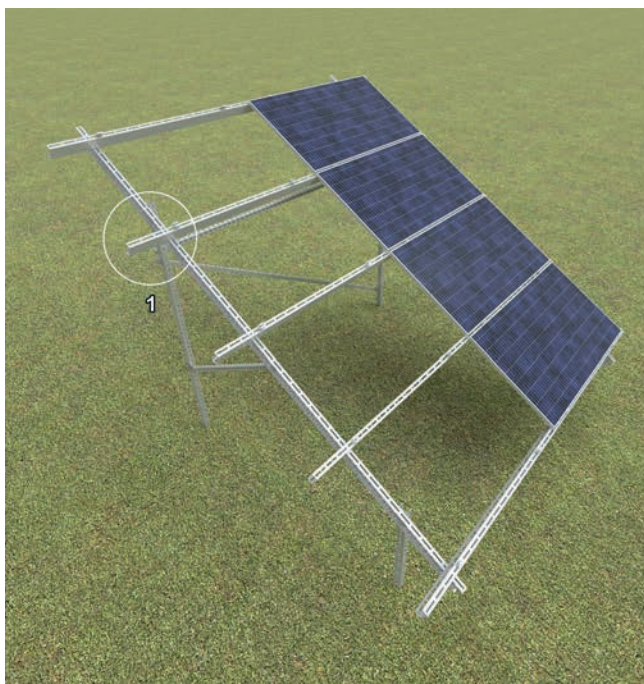

Mounting structures for the Installation of photovoltaic panels - support elements

Support Channel

CWE100H50...NMC mat.: MC

symbol	catalogue number	dimension L [mm]	weight 1 pc. [kg]	quantity per package [pcs.]	min. order [pcs.]	STM ST
Material thickness = 4.0 mm						
CWE100H50/1,5NMC	865115	1479	9.53	8	50	ST
CWE100H50/3,2NMC	865132	3213	20.33	8	1	STM
CWE100H50/3,6NMC	865136	3621	22.24	8	1	STM

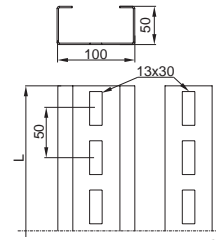

Use:

Load-bearing structure element - vertical support posts for free-standing structures.

Additional information:

- dense perforation enables the levelling of unevenness created during the assembly of the structure in inhomogeneous ground and enables the assembly of the structure with a slightly changed angle of inclination

Channel

CBT70H50...MC mat.: MC

symbol	catalogue number	dimension L [mm]	weight 1 pc. [kg]	quantity per package [pcs.]	min. order [pcs.]	N STM ST
Material thickness = 3.0 mm						
CBT70H50/3MC	867603	3000	10.67	4	50	ST
CBT70H50/4MC	867604	4000	13.80	4	1	STM

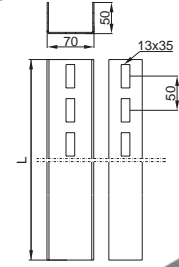
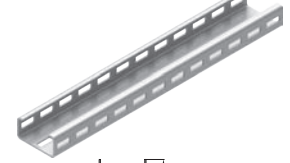

Use:

Load-bearing structure element - vertical support posts for free-standing structures.

Additional information:

- the part driven into the ground without perforation – increased mechanical strength and improved sliding facilitate pile driving in difficult soil conditions
- the above-ground part with dense perforation allows leveling of installation and terrain irregularities and adjustment of the panel tilt angle relative to the ground
- use SGKFM10x20PV bolts for mounting

Support Channel

CWBT70H50...MC mat.: MC

symbol	catalogue number	dimension L [mm]	weight 1 pc. [kg]	quantity per package [pcs.]	min. order [pcs.]	N STM ST
Material thickness = 3.0 mm						
CWBT70H50/2,4MC	867524	2400	10.03	4	50	ST
CWBT70H50/3MC	867503	3000	12.22	4	1	STM
CWBT70H50/3,2MC	867532	3200	13.08	4	50	ST
CWBT70H50/4,4MC	867534	4400	15.31	4	1	STM

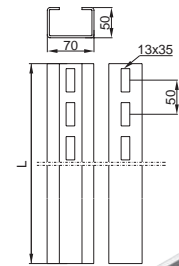
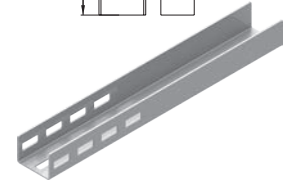

Use:

Load-bearing structure element - vertical support posts for free-standing structures.

Additional information:

- the part driven into the ground without perforation – increased mechanical strength and improved sliding facilitate pile driving in difficult soil conditions
- the above-ground part with dense perforation allows leveling of installation and terrain irregularities and adjustment of the panel tilt angle relative to the ground
- use SGKFM10x20PV bolts for mounting

1 - Assembly of W-V2G2-BI structure on CWBT70H50...MC channels

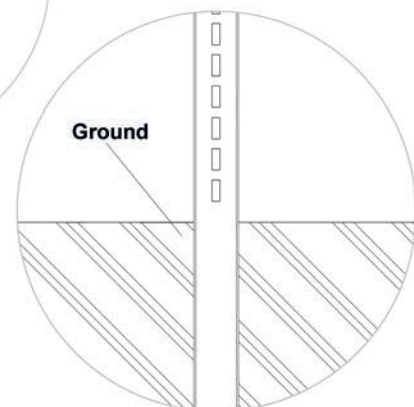
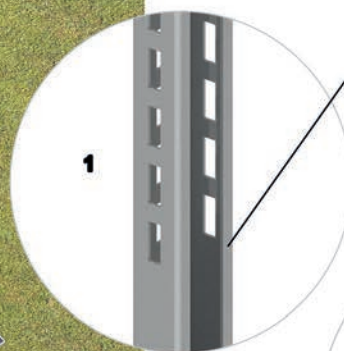
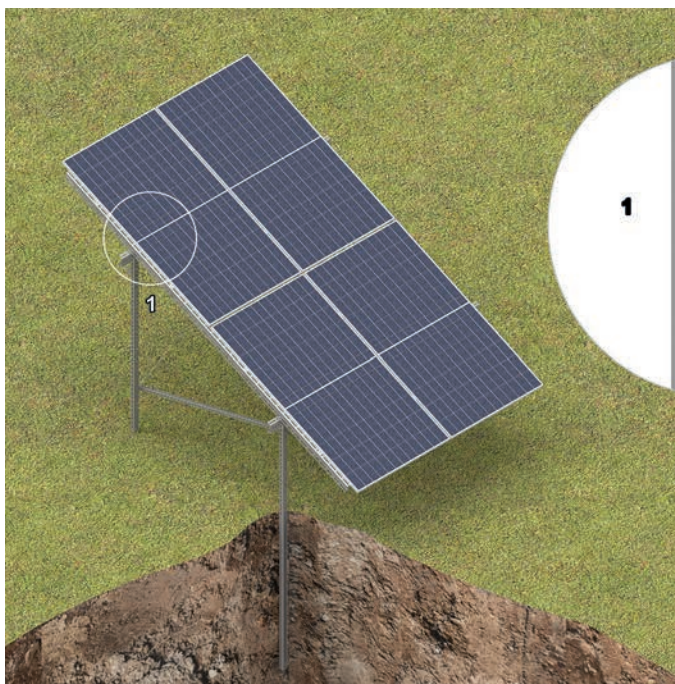

Mounting structures for the Installation of photovoltaic panels - support elements

Support Channel **CMP41H41...MC** mat.: MC

symbol	catalogue number	dimension L [mm]	weight 1 pc. [kg]	quantity per package [pcs.]
Material thickness = 1.5 mm				
CMP41H41/1MC	6441105	1000	1.32	8
CMP41H41/1,2MC	856211	1200	1.69	8
CMP41H41/1,5MC	856215	1500	2.11	8
CMP41H41/1,7MC	851117	1700	2.40	8
CMP41H41/2MC	6441205	2000	2.64	8
CMP41H41/2,2MC	851122	2200	3.11	8
CMP41H41/2,5MC	851125	2500	3.55	8
CMP41H41/3MC	6441305	3000	3.96	8
CMP41H41/3,5MC	851135	3500	4.73	8
CMP41H41/3,7MC	852137	3700	5.01	8
CMP41H41/6MC	6441605	6000	7.92	8

N **STM**

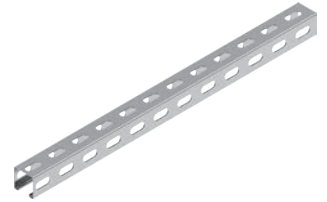
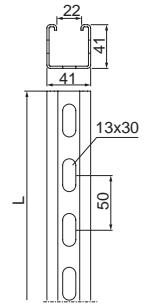

Use:

Creation of triangular structures for flat roofs.

Additional information:

- produced in various lengths, which significantly extends the Installation possibilities
- a "double bend" on the open side of the channel section, which provides additional strength and stiffness to the element
- use SGKFM10x20PV bolts for mounting

Connector **LC41H41MC** mat.: MC option: F

symbol	catalogue number	weight 1 pc. [kg]	quantity per package [pcs.]
Material thickness = 1.5 mm			
LC41H41MC	6444115	0.30	50

STM

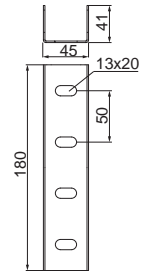

Use:

Connecting CM...41H41...MC channels.

Additional information:

- use SGKFM10x20 or SGFM10x20 bolts to join the channel with the connector
- perforation on 3 sides allows various bolt placement configurations
- for the assembly use 6 x SGKFM10x20PV Screw Sets

1 - Assembly of DP-DNHBE-WZ structure with CMP41H41...MC Channels



Channel	CC55H50...MC	mat.: MC			
symbol	catalogue number	dimension L [mm]	weight 1 pc. [kg]	quantity per package [pcs.]	STM
Material thickness = 2.0 mm					
CC55H50/0,6MC	895406	600	1.21	20	
CC55H50/0,7MC	895407	700	1.42	20	
CC55H50/1MC	6121105	1000	2.02	8	
CC55H50/1,35MC	895535	1350	2.71	8	
CC55H50/1,55MC	895525	1550	3.03	8	
CC55H50/2MC	6121205	2000	4.05	8	
CC55H50/2,6MC	895327	2600	5.22	8	
CC55H50/3MC	6121305	3000	6.09	4	

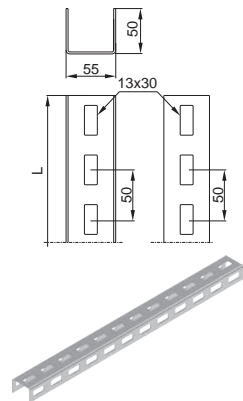

Use:

Creation of triangular structures for flat roofs.

Additional information:

- quick creation of triangular structures on flat roofs
- für die Montage sind SGKFM10x20PV oder SMM10x70F + PP10F

Channel	CP50H35...MC	mat.: MC			
symbol	catalogue number	dimension L [mm]	weight 1 pc. [kg]	quantity per package [pcs.]	STM
Material thickness = 1.5 mm					
CP50H35/0,25MC	895625	250	0.28	1	
CP50H35/0,3MC	895603	300	0.33	1	
CP50H35/0,35MC	895635	350	0.39	1	
CP50H35/0,45MC	895604	450	0.49	1	
CP50H35/0,55MC	895605	550	0.60	1	
CP50H35/1,3MC	895613	1300	1.43	1	
CP50H35/1,5MC	895615	1500	1.62	1	

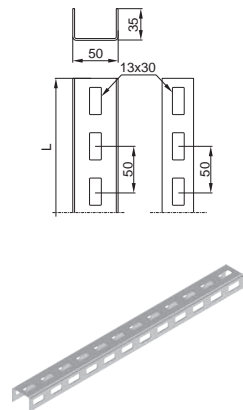

Additional information:

- für die Montage sind SGKFM10x20PV oder SMM10x70F + PP10F

A - Assembly of DP-DTVKN structure with CC50H35...MC and CC55H50...MC Channels
 B - Assembly of DP-DTAVKN structure with KT...A Angle Profiles

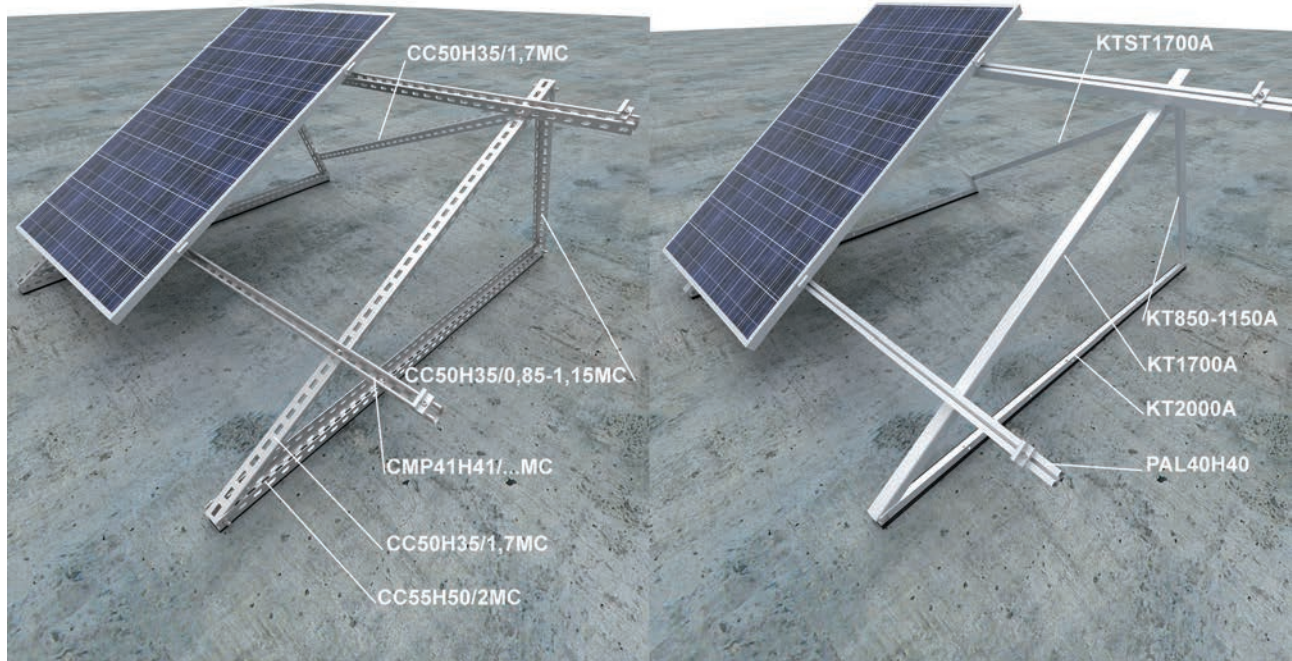

Support Channel

CC50H35...MC mat.: MC

symbol	catalogue number	dimension L [mm]	weight 1 pc. [kg]	quantity per package [pcs.]
--------	------------------	------------------	-------------------	-----------------------------

STM

Material thickness = 2.0 mm

CC50H35/0,85MC	895385	850	1.48	1
CC50H35/1,0MC	895335	1000	1.75	1
CC50H35/1,15MC	895325	1150	2.01	1
CC50H35/1,35MC	895336	1350	2.36	1
CC50H35/1,55MC	895365	1550	2.70	1
CC50H35/1,7MC	895375	1700	2.97	1
CC50H35/2,2MC	895322	2200	3.85	1
CC50H35/3,3MC	895333	3300	5.77	1

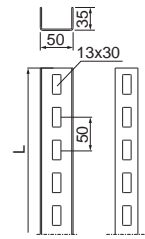

Use:

Creation of triangular structures for flat roofs.

Additional information:

– für die Montage sind SGKFM10x20PV oder SMM10x70F + PP10F

Channel connector

LCCW50H35MC mat.: MC

symbol	catalogue number	weight 1 pc. [kg]	quantity per package [pcs.]
--------	------------------	-------------------	-----------------------------

STM

Material thickness = 2.0 mm

LCCW50H35MC	620415	0.26	50
-------------	--------	------	----

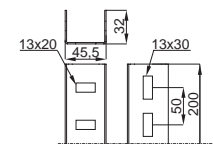

Use:

Connecting profiles.

Additional information:

– perforation on 3 sides allows various bolt placement configurations
– for the assembly use 6 x SGKFM10x20PV Screw Sets



Channel

CCS50H35/...MC mat.: MC

symbol	catalogue number	dimension L [mm]	weight 1 pc. [kg]	quantity per package [pcs.]
--------	------------------	------------------	-------------------	-----------------------------

ST

Material thickness = 2.0 mm

CCS50H35/1,3MC	895413	1300	2.00	1
CCS50H35/1,4MC	895414	1400	2.08	1

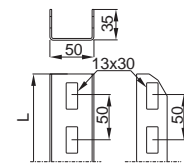

Use:

Creation of triangular structures for flat roofs.

Additional information:

– use SGKFM10x20PV bolts for mounting

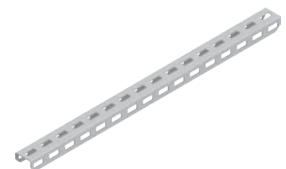

A - Assembly of DP-DTVKN structure with CC50H35...MC and CC55H50...MC Channels
B - Assembly of DP-DTAVKN structure with KT...A Angle Profiles





Aluminium angle profile **KT...A** mat.: A

symbol catalogue number dimension L [mm] weight 1 pc. [kg] quantity per package [pcs.]

ST

Material thickness = 3.0 mm

KT850A	898085	850	1.53	1
KT1000A	898099	1000	1.80	1
KT1150A	898115	1150	2.01	1
KT1700A	898170	1700	3.06	1
KT2000A	898210	2000	3.60	1
KTST1700A	898175	1700	3.06	1

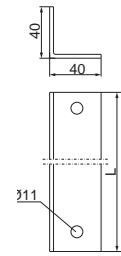

Use:

Forming triangular PV panel structures.

Additional information:

- perforation suitable for different panel sizes to enable Installation in designated Installation zones on the panel frame
- for the assembly use SSZ10x20E Screws and NKZM10E Nuts

A - Assembly of DP-DTVKN structure with CC50H35...MC and CC55H50...MC Channels
 B - Assembly of DP-DTAVKN structure with KT...A Angle Profiles

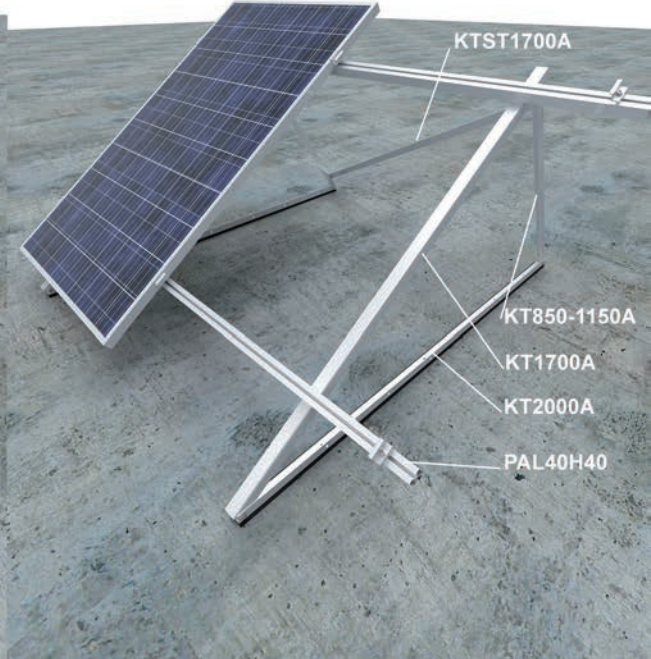
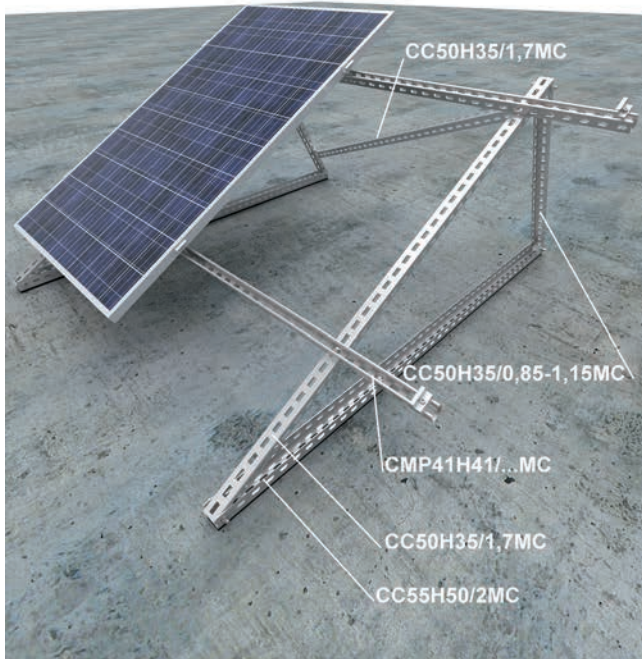

Base Plate	PCS70	mat.: F	quantity per package [pcs.]
symbol	catalogue number	weight 1 pc. [kg]	quantity per package [pcs.]
PCS70	751217	1.81	5

ST

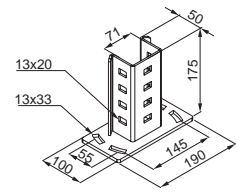

Use:
Assembly of vertical profile CT70H50... and CWT70H50... as a support post of the structure to GSW76x...N ground screw.

Additional information:

- special shape of the profile to increase its strength
- holes in the base plate allowing adjustment of the position during assembly
- for assembly to ground screw use 4 x SMM10x30F Screw Sets
- for assembly channel use 6 x SGKFM10x20PV

Base Plate	PCS100	mat.: F	quantity per package [pcs.]
symbol	catalogue number	weight 1 pc. [kg]	quantity per package [pcs.]
PCS100	751216	2.17	5

ST

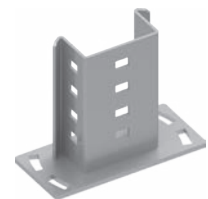
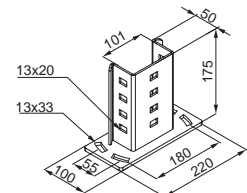

Use:
Assembly of vertical profile CWE100H50... as a support post of the structure to GSW76x...N ground screw.

Additional information:

- special shape of the profile to increase its strength
- holes in the base plate allowing adjustment of the position during assembly
- for assembly to ground screw use 4 x SMM10x30F Screw Sets
- for assembly channel use 6 x SGKFM10x20PV

Assembly of PCS... Base Plates to the ground using GSW...N Ground Screws

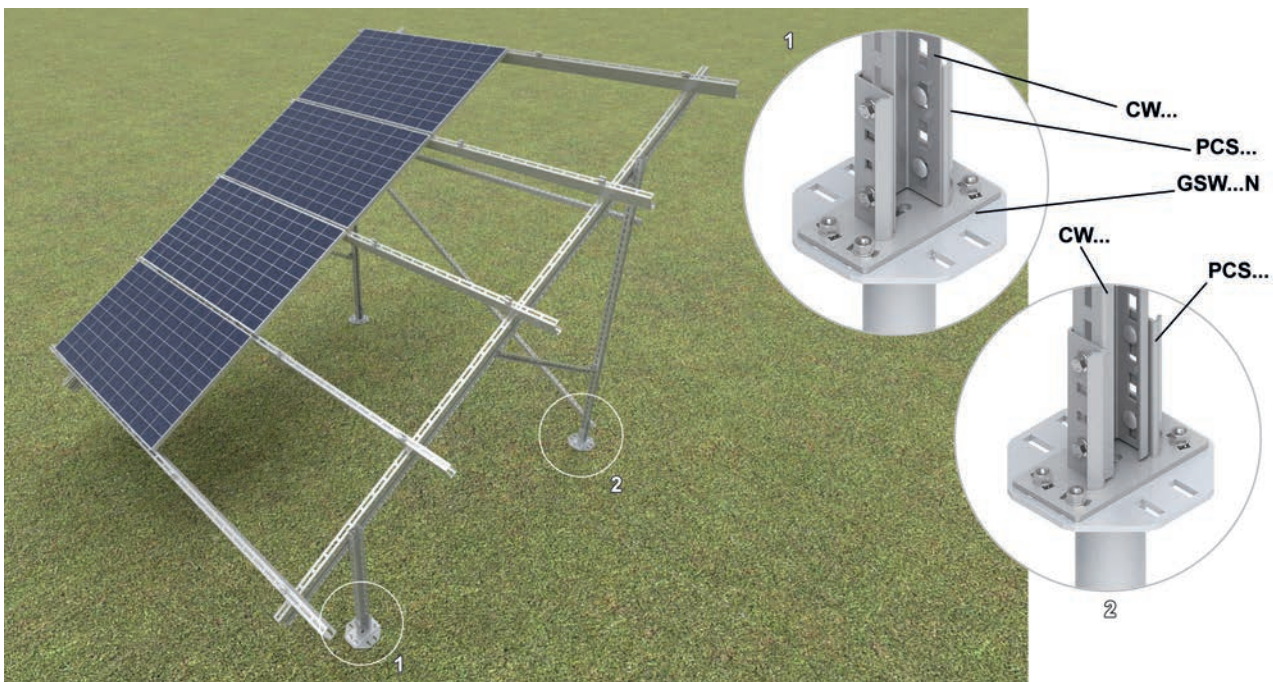

Ground Screw GSW76x...N mat.: F

symbol	catalogue number	dimension L [mm]	weight 1 pc. [kg]	quantity per package [pcs.]
GSW76x1600N	897716	1600	11.00	1
GSW76x2200N	897722	2200	12.90	1

ST

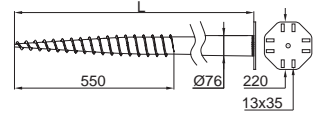

Use:
Anchoring to the ground of the free standing structure for photovoltaic panels.

Additional information:

- longitudinal perforation enables screw assembly with PCS70 or PCS100 base plates
- installation of small and medium-sized freestanding structures without the need for using pile driver
- increased bearing capacity (compaction) of the soil when screwing in the screw
- hot-dip galvanized material for very high corrosion resistance
- for assembly to ground screw use 4 x SMM10x30F Screw Sets

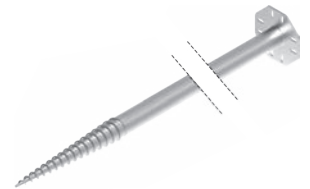

Head Plate PSF70x50MC mat.: MC

symbol	catalogue number	weight 1 pc. [kg]	quantity per package [pcs.]
Material thickness = 3.0 mm			
PSF70x50MC	7141285	0.95	10

N STM

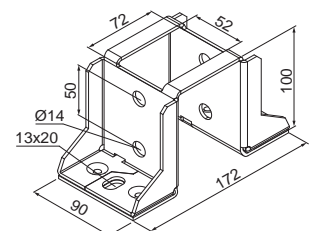

Use:
Forming of load-bearing structures.

Additional information:

- assembly of vertical profile CT70H50... and CWT70H50... as a support post of the structure to concrete foundation

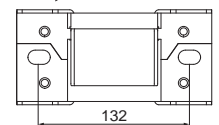

Assembly of PCS... Base Plates to the ground using GSW...N Ground Screws

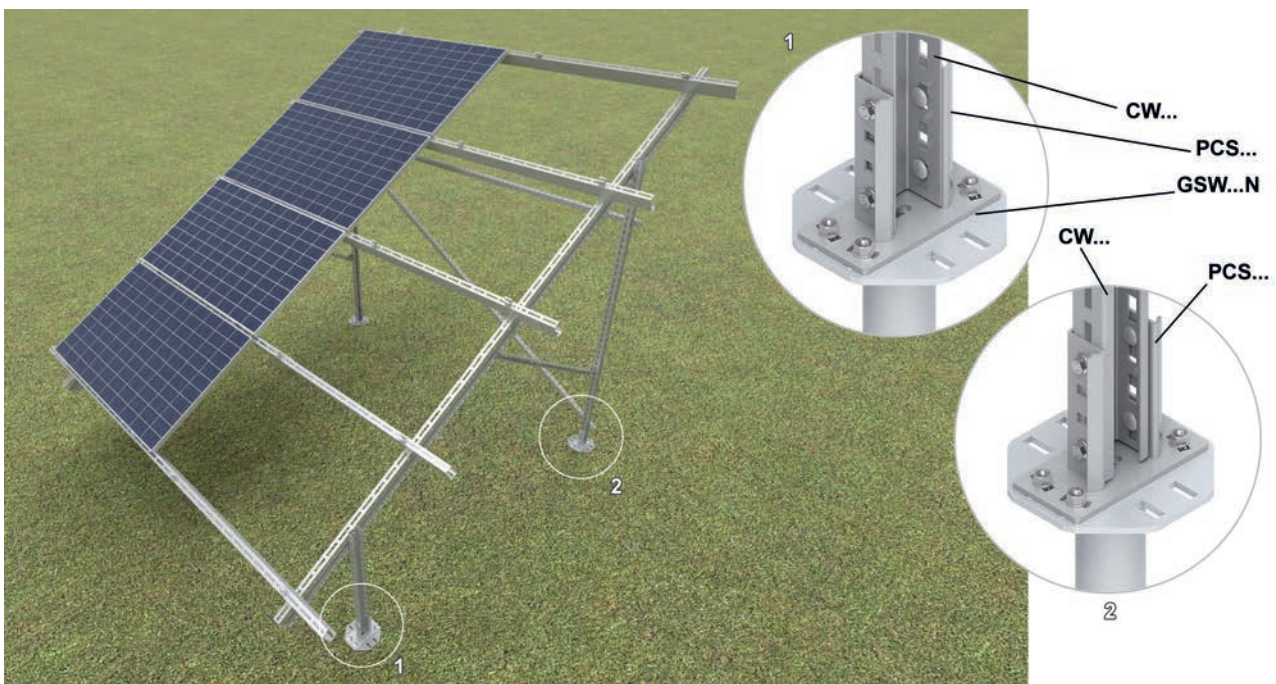

Mounting structures for the Installation of photovoltaic panels - support elements

Base Plate	PCB70	mat.: F		
symbol	catalogue number	weight 1 pc. [kg]	quantity per package [pcs.]	
PCB70	751218	4.32	5	

N ST

Use:
Assembly of vertical profile CT70H50... and CWT70H50... as a support post of the structure to concrete foundation.

Additional information:

- special shape of the profile to increase its strength
- holes in the base plate allowing adjustment of the position during assembly
- dense perforation in the vertical part allows mounting height adjustment of the support post
- high mounting stability due to the enlarged base plane
- for assembly to concrete foundation use 4 x PSRM10x90F Anchor Bolts
- for assembly channel use 6 x SGKFM10x20PV

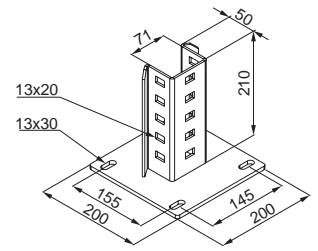

Base Plate	PCB100	mat.: F		
symbol	catalogue number	weight 1 pc. [kg]	quantity per package [pcs.]	
PCB100	751219	4.87	5	

N ST

Use:
Assembly of vertical profile CWE100H50 as a support post of the structure to concrete foundation.

Additional information:

- special shape of the profile to increase its strength
- holes in the base plate allowing adjustment of the position during assembly
- dense perforation in the vertical part allows mounting height adjustment of the support post
- high mounting stability due to the enlarged base plane
- for assembly to concrete foundation use 4 x PSRM10x90F Anchor Bolts
- for assembly channel use 6 x SGKFM10x20PV

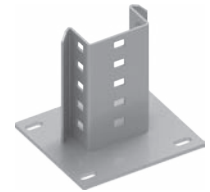
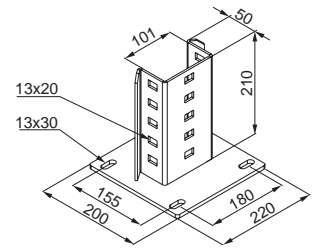

1 - Assembly of PCB70 Base Plate to concrete foundation

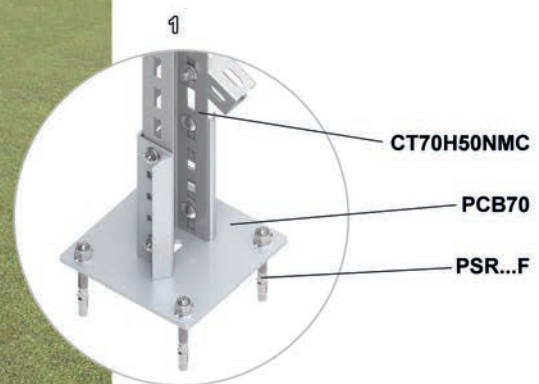
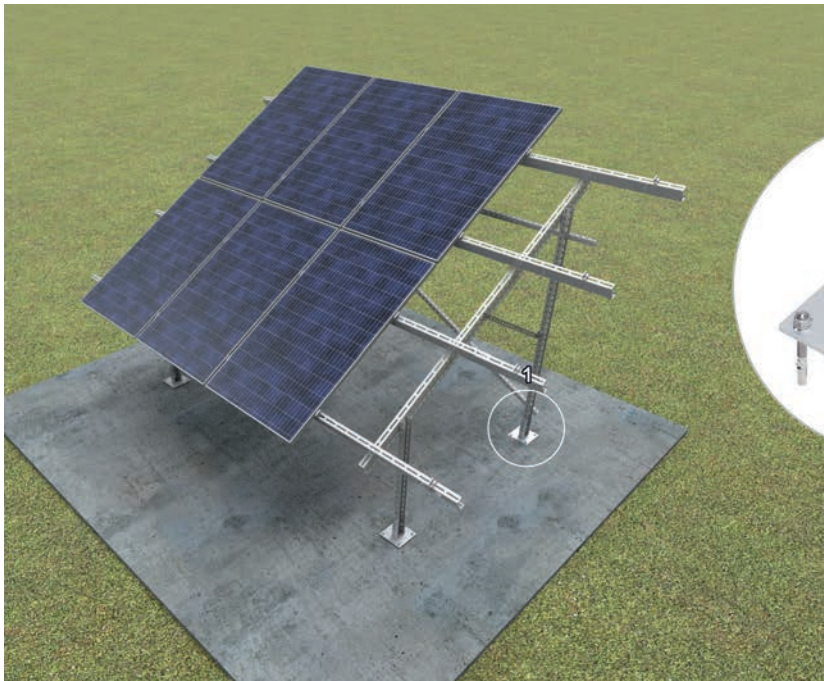

Structures for mounting photovoltaic panels - mounting elements

Channel connector	LC...70NMC	mat.: MC	quantity per package [pcs.]
symbol	catalogue number	weight 1 pc. [kg]	
Material thickness = 3.0 mm			
LCJ70NMC	850252	0.18	30
LCD70NMC	850155	0.25	30

STM

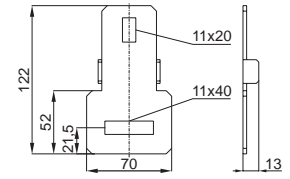

Use:
 Connection of bracings made of CMP... channels with CT70H50...NMC, CBT70H50...MC, CWBT70H50...MC or CWT70H50...NMC vertical support posts of double-supported freestanding structures.

Additional information:

- longitudinal perforation allows for mounting the element to support posts in the correct position
- modified bends ensure high strength and stable assembly
- for the assembly use 2 x SGKFM10x20PV Screw Sets

Channel connector	LCD100NMC	mat.: MC	quantity per package [pcs.]
symbol	catalogue number	weight 1 pc. [kg]	
Material thickness = 3.0 mm			
LCD100NMC	850154	0.29	20

STM

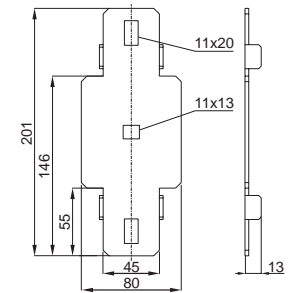

Use:
 Connection of bracings made of CMP... channels with CT70H50...NMC, CBT70H50...MC, CWBT70H50...MC or CWT70H50...NMC vertical support posts of double-supported freestanding structures.

Additional information:

- longitudinal perforation allows for mounting the element to support posts in the correct position
- modified bends ensure high strength and stable assembly
- for the assembly use 2 x SGKFM10x20PV Screw Sets

Assembly of LC...70MC Channel Connector with CWT70H50...NMC Support Channels

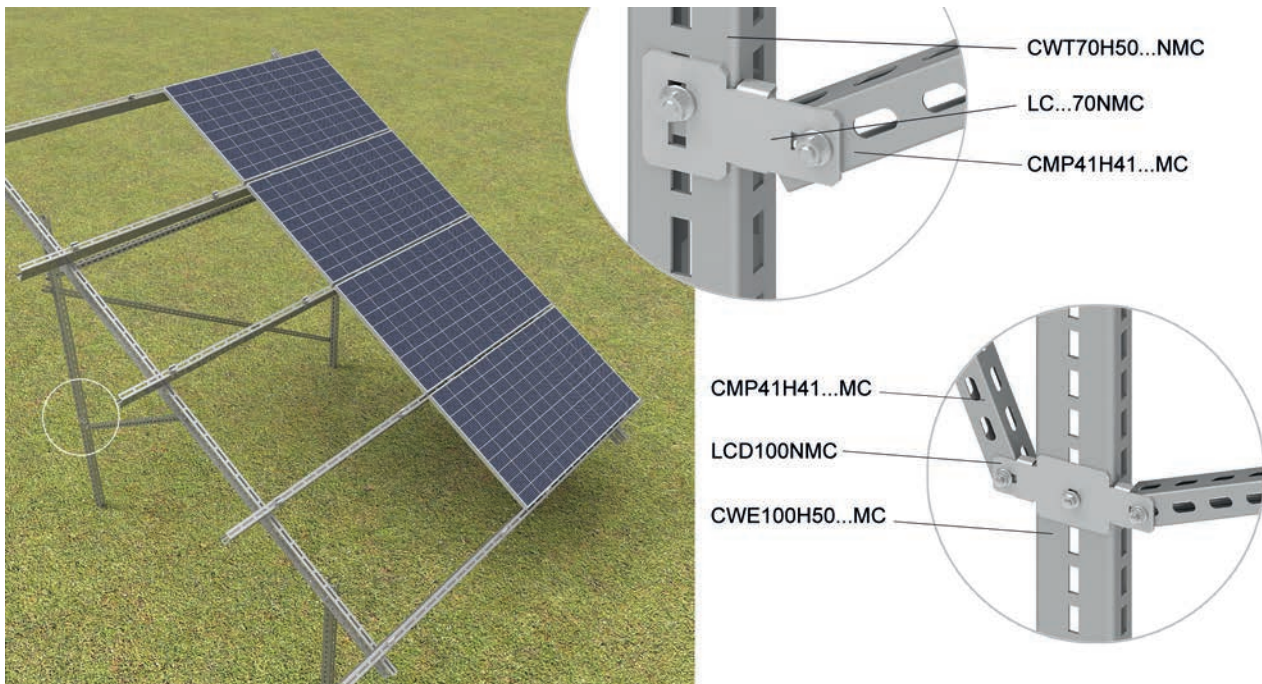



Connector	SPV	mat.: E	
symbol	catalogue number	weight 1 pc. [kg]	quantity per package [pcs.]
SPV	864205	0.03	100

N ST

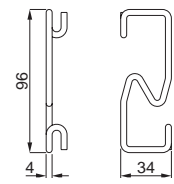

Use:

Protection against falling out of cables routed inside of CWC100H50...MC or CWC100H50...NMC channel.

Additional information:

- very quick Installation and removal of the clip, allowing cables to be added at any time
- the round cross-section of the clip protects the cables from damage
- low weight allowing to carry a large number of pieces by one installer
- installation possible anywhere in channel



Assembly of SPV Wire Clip with CWC100H50...MC or CWC100H50...NMC Support Channel

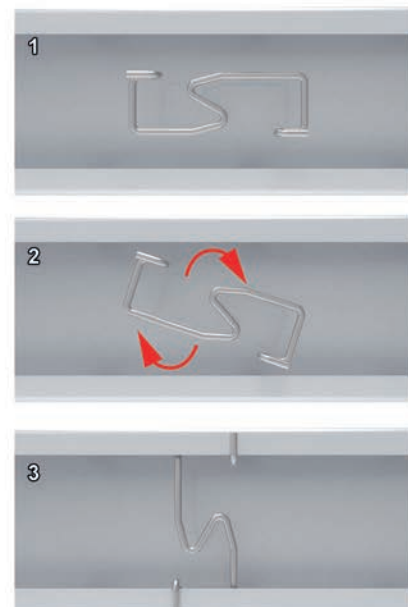
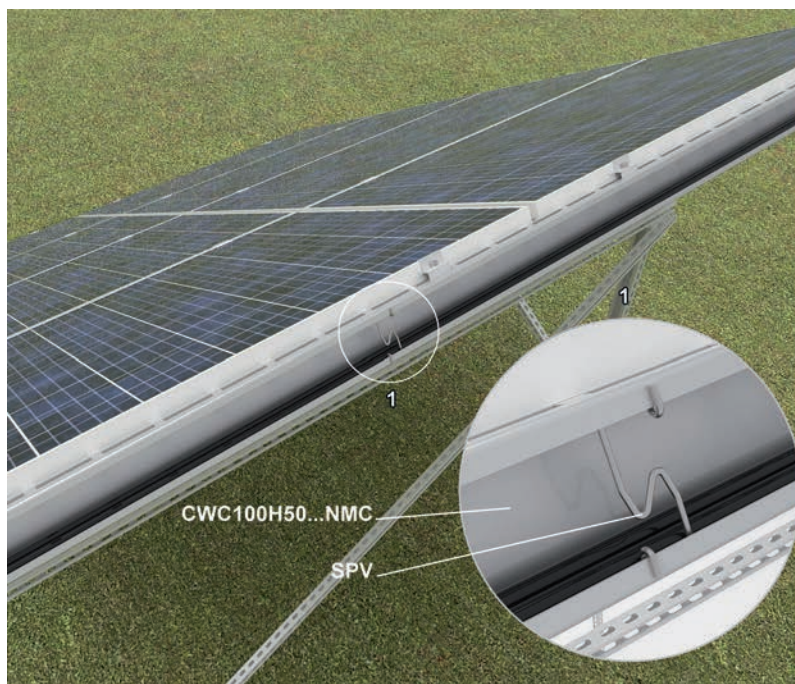

E - stainless steel

Profile Connector	LBDFEMC	mat.: MC		
symbol	catalogue number	weight 1 pc. [kg]	quantity per package [pcs.]	
Material thickness = 4.0 mm				
LBDFEMC	852003	1.25	1	

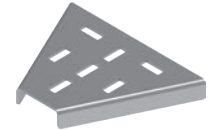
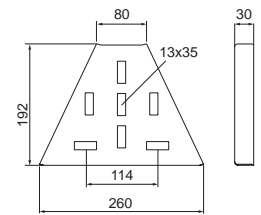

Use:
Connection of BDFCH120/...NMC profiles with channels in W-Z free-standing structures.

Additional information:

- longitudinal perforation allows for mounting the element to support posts in the correct position
- modified bends ensure high strength and stable assembly
- for the assembly use 3 x SGKFM10x20PV Screw Sets

1 - Assembly of LBDFEMC Profile Connector

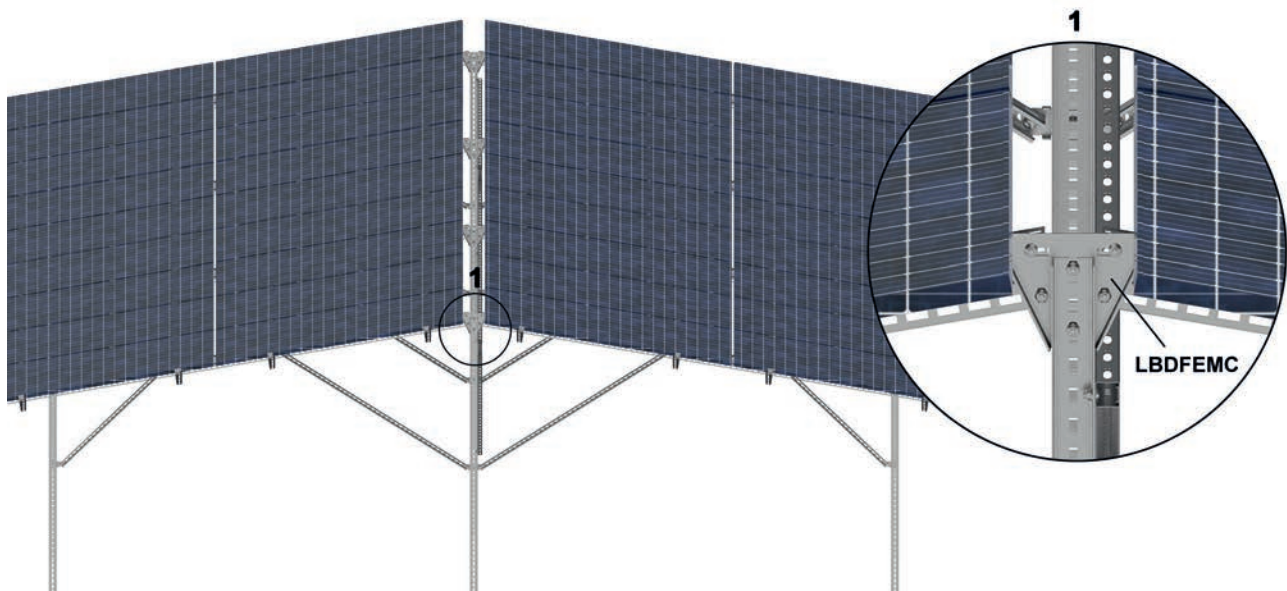

MC - steel in Magnelis® coating, E - stainless steel

Structures for mounting photovoltaic panels - mounting elements

Steel Fixing Plate for Flat Roofs SPM1

mat.: MC option: E

symbol	catalogue number	weight 1 pc. [kg]	quantity per package [pcs.]
--------	------------------	----------------------	-----------------------------------



Material thickness = 2.0 mm

SPM1	858023	0.80	10
------	--------	------	----

Use:

Installation to a flat roof covered with roofing felt or membrane.

Additional information:

- non-invasive Installation to roofs covered with roofing felt or membrane
- geometry and load capacity adapted to the BAKS structures
- low weight, which does not overload the roof
- the set includes an enlarged washer, a spring washer and a stainless steel nut
- threaded mandrel M8x30 permanently fixed to the plate
- attention.

minimum patch size for SPM1 fixing plates:

- for roofing felt: 500 x 1000 mm

- membrane: 300 x 700 mm

- note:

installation instructions of the plate for flat roof can be found on the website www.baks.com.pl/en/

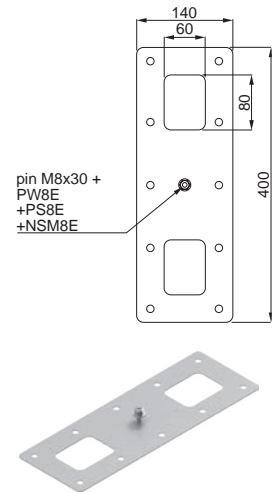

Steel Fixing Plate for Flat Roofs SPM2

mat.: MC option: E

symbol	catalogue number	weight 1 pc. [kg]	quantity per package [pcs.]
--------	------------------	----------------------	-----------------------------------



Material thickness = 2.0 mm

SPM2	858024	1.50	10
------	--------	------	----

Use:

Installation to a flat roof covered with roofing felt or membrane.

Additional information:

- non-invasive Installation to roofs covered with roofing felt or membrane
- geometry and load capacity adapted to the BAKS structures
- low weight, which does not overload the roof
- the set includes an enlarged washer, a spring washer and a stainless steel nut
- threaded mandrel M8x30 permanently fixed to the plate
- attention.

minimum patch size for SPM2 fixing plates:

- for roofing felt: 500 x 1200 mm

- membrane: 300 x 1000 mm

- note:

installation instructions of the plate for flat roof can be found on the website www.baks.com.pl/en/

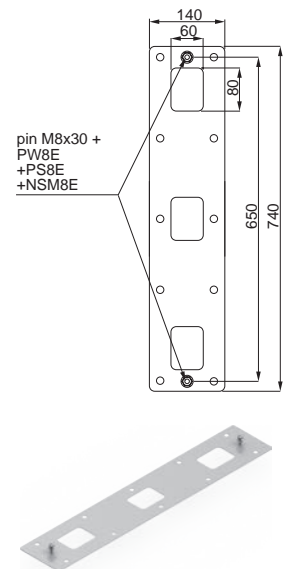

Assembly of SPM2 Steel Fixing Plate on a flat roof covered with roofing felt

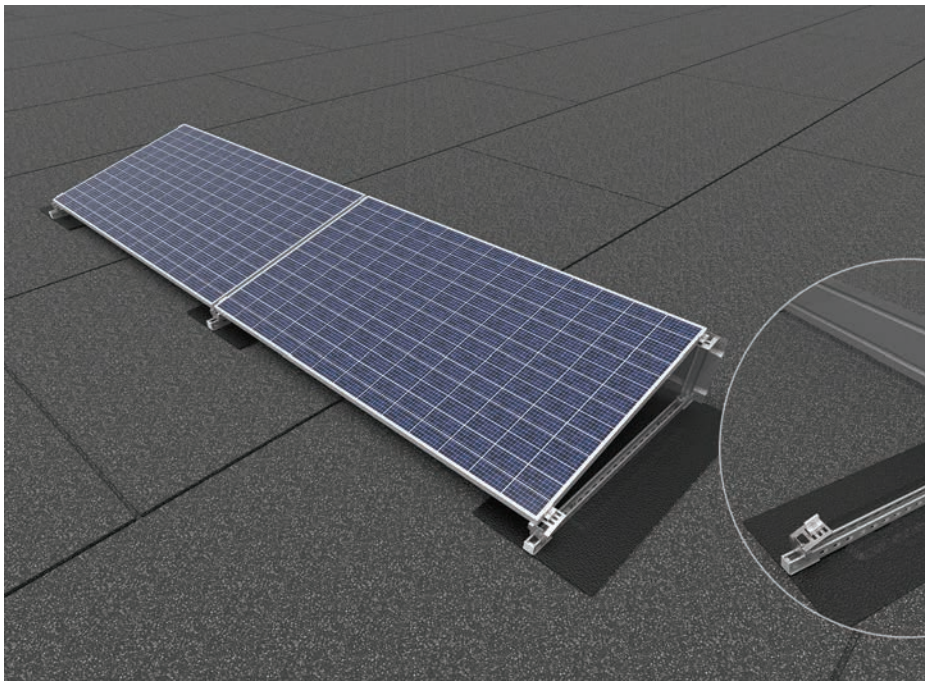

Assembly instructions for SPM2 Steel Fixing Plate to roofing felt
Note:

Requirements of the roofing felt to be used:

- 1) EN 12310-1 min 150N
- 2) EN 12311-1 min 300N/50 mm
- 3) EN 12316-1 min 125N/50 mm
- 4) EN 12317-1 min 500N/50 mm

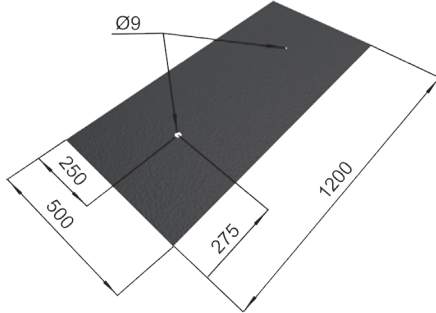

1. Before starting to install the SPM2 plates, cut out a fragment of roofing felt with minimum dimensions of 500 x 1200 mm, then cut out holes with a diameter of Ø9 mm in the locations of screws

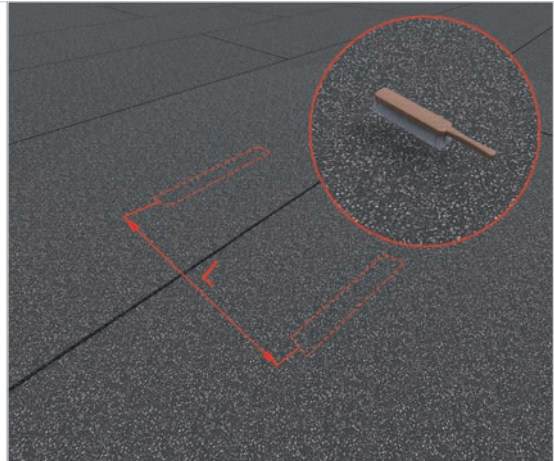

2. Measure the distance between the SPM2 plates, mark the points and then use a wire brush to clean the 500 x 1200 mm area of the roofing felt on the roof

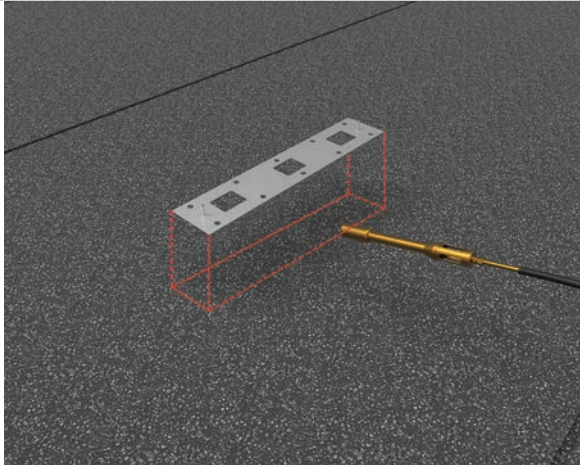

3. On the designated area heat the surface in the size of a plate or slightly larger

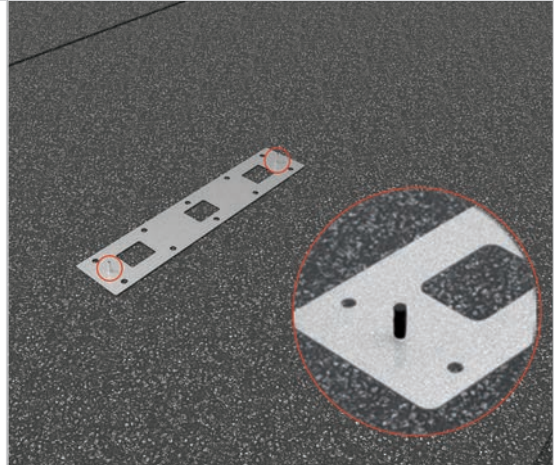

4. SPM2 plate should be placed on heated areas, pressed against prepared surface, protruding threads should be secured with NOP50 protection cap

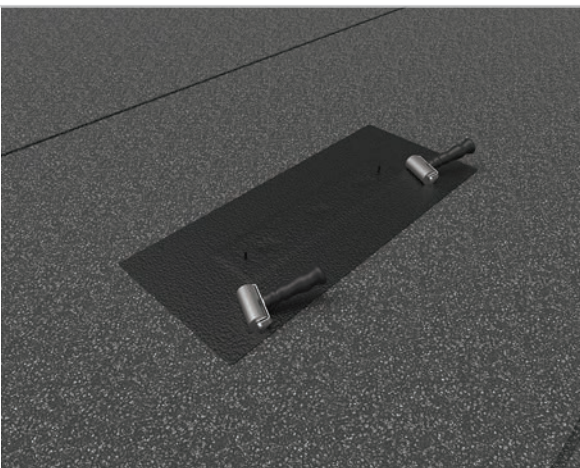

5. Warm up the prepared roofing felt, cover the plate with it and then press it with a roofing roller in the locations of the holes
 6. Warm up the side of the roofing felt and the surface and at the same time press the roofing felt with a roofing roller, repeat the operation for each side until the plate is fully fixed to the roof surface

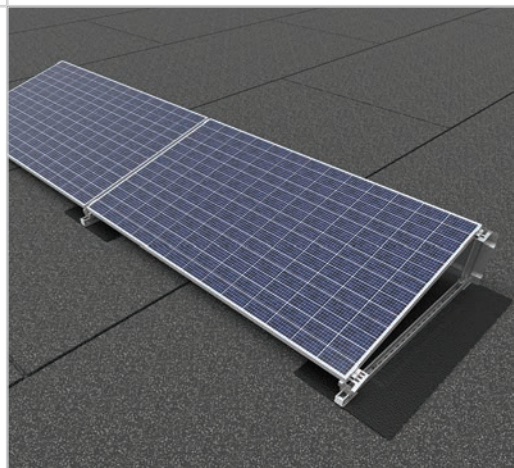

7. Correctly installed structure using SPM2 plate and DP-DNHWE mounting system

Assembly instructions for SPM2 Steel Fixing Plate to membrane

Note:

Requirements of the membrane to be used: PVC, ECB, EPO min 1.2 mm thick:

- 1) EN 12310-2 min 110N
- 2) EN 12311-2 min 500N/50 mm
- 3) EN 12316-2 min 150N/50 mm
- 4) EN 12317-2 min 450N/50 mm

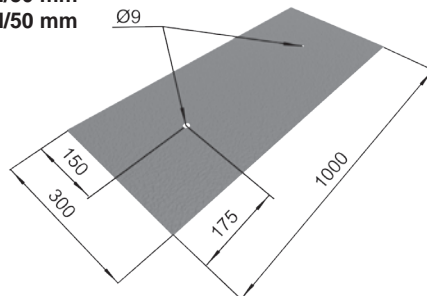

1. Before starting to install the SPM2 plates, cut out a fragment of membrane with minimum dimensions of 300 x 1000 mm, then cut out holes with a diameter of Ø9 mm in the locations of screws, finally round the corners of the membrane

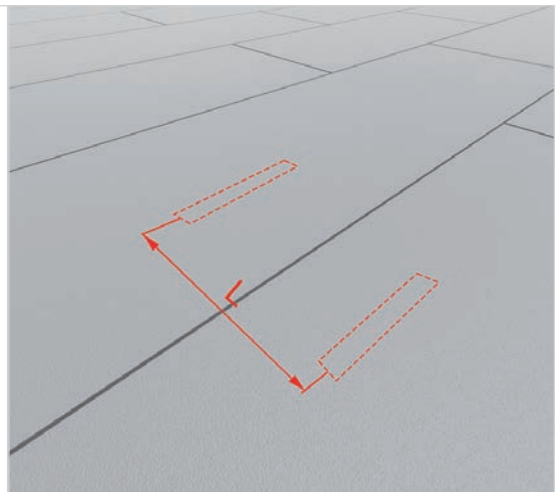

2. Measure the distance between the SPM2 plates, then mark the points

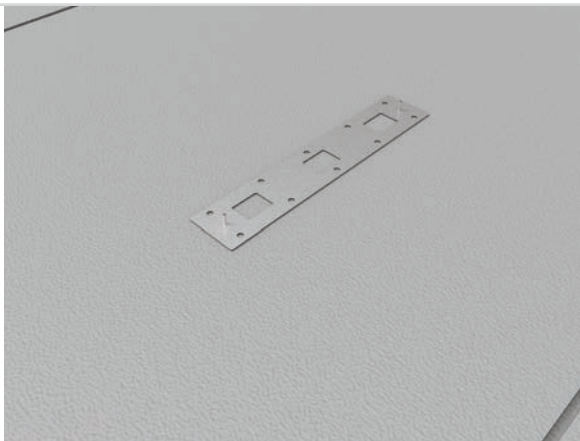

3. Place the SPM2 plate on the designated place

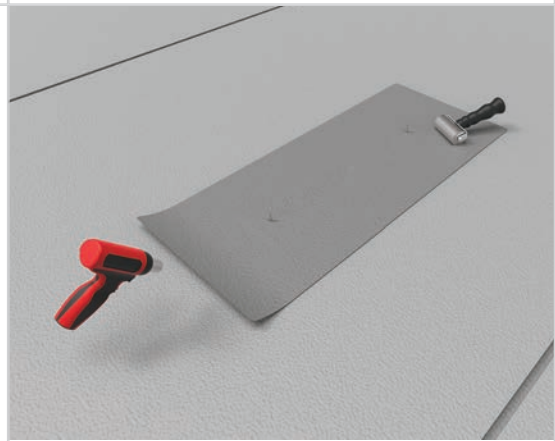

4. Cover the SPM2 plate with the prepared membrane and start the installation with a manual welding machine. Initially weld an hole of 60 x 80 mm, after proper heating press the membrane with a roofing roller. Repeat for the remaining holes

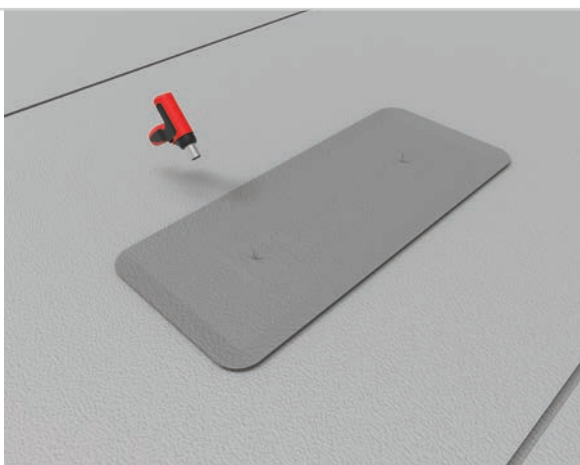

5. Once the holes are welded, weld all sides around the SPM2 plate
6. The SPM2 plate glued to the membrane is a basis for a structure for PV Installations

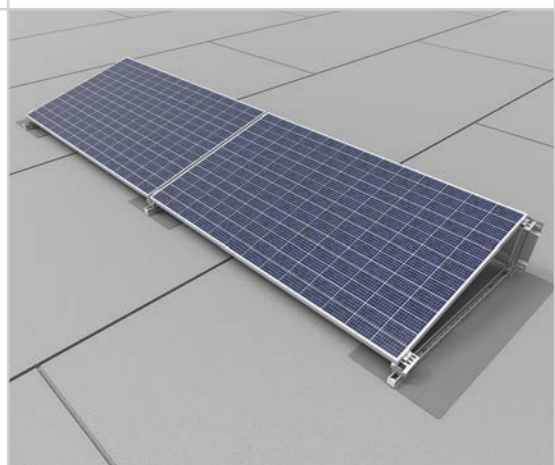

7. Correctly installed structure using SPM2 plate and DP-DNHWE mounting system

Steel Fixing Plate for Flat Roofs SPM3 mat.: MC option: E

symbol	catalogue number	weight 1 pc. [kg]	quantity per package [pcs.]
--------	------------------	-------------------	-----------------------------

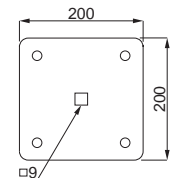

Material thickness = 2.0 mm

SPM3	858025	0.80	10
------	--------	------	----

Use:

Installation to a flat roof covered with roofing felt or membrane.

Additional information:

- non-invasive Installation to roofs covered with roofing felt or membrane
- geometry and load capacity adapted to the BAKS structures
- low weight, which does not overload the roof
- attention.

minimum patch size for SPM3 fixing plates:

- membrane: 350 x 350 mm
- use SGK8x30E + PW8E bolts for mounting

Connector LCCNMC mat.: MC

symbol	catalogue number	weight 1 pc. [kg]	quantity per package [pcs.]
--------	------------------	-------------------	-----------------------------

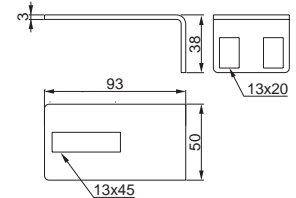

Material thickness = 3.0 mm

LCCNMC	858022	0.08	50
--------	--------	------	----

Use:

Assembly CWC100H50...MC profile to BDFCH120...MC profiles when the Installation place does not coincide with the factory perforation.

Additional information:

- longitudinal perforation allows for mounting the element to support posts in the correct position
- for the assembly use 3 x SGKFM10x20PV Screw Sets
- allows mounting without drilling

Assembly of SPM2 Steel Fixing Plate on a flat roof covered with membrane

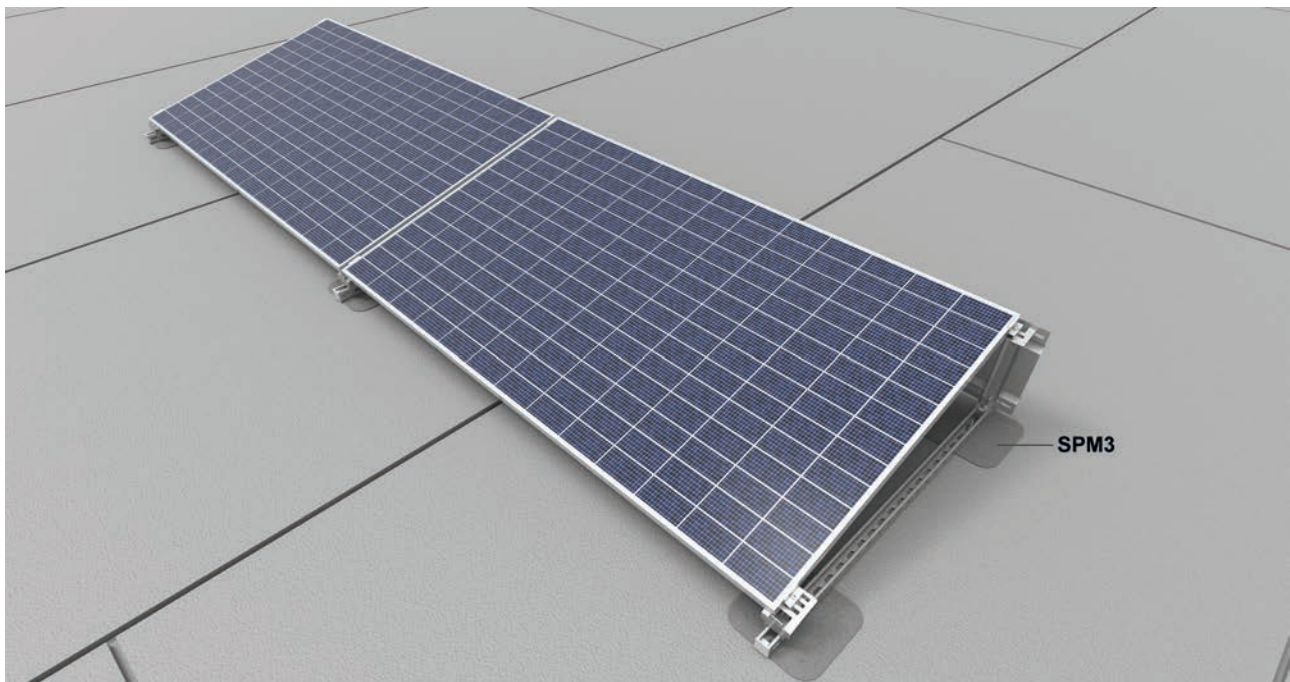

Assembly instructions for SPM3 Steel Fixing Plate to membrane

Note:

Requirements of the membrane to be used: PVC, ECB, EPO min 1.2 mm thick:

- 1) EN 12310-2 min 110N
- 2) EN 12311-2 min 500N/50 mm
- 3) EN 12316-2 min 150N/50 mm
- 4) EN 12317-2 min 450N/50 mm

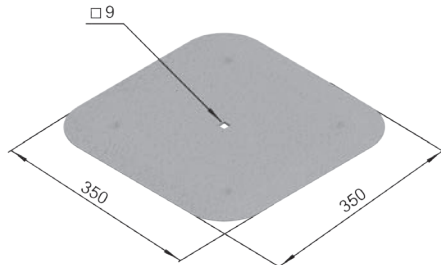

1. Before starting to install the SPM3 plates, cut out a fragment of membrane with minimum dimensions of 350 x 350 mm, then cut out holes with a diameter of $\varnothing 9$ mm in the locations of screws, finally round the corners of the membrane

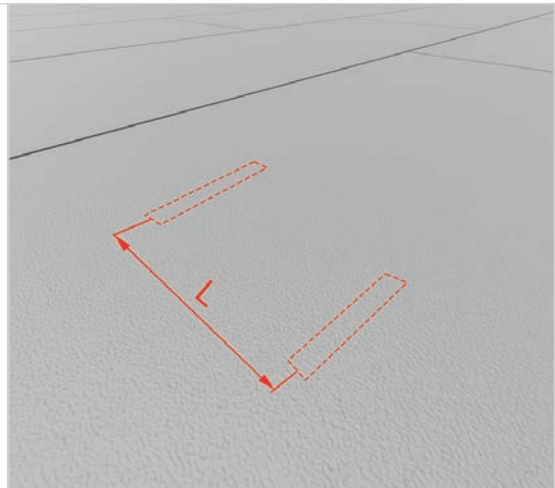

2. Measure the distance between the SPM3 plates, then mark the points

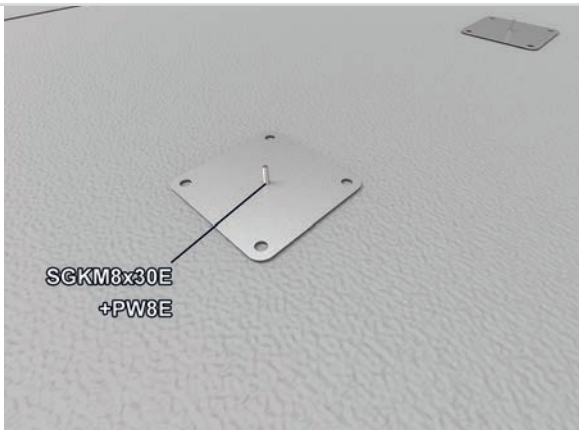

3. Place the SPM3 plate on the designated place (use SGKM8x30E + PW8E bolts for mounting)

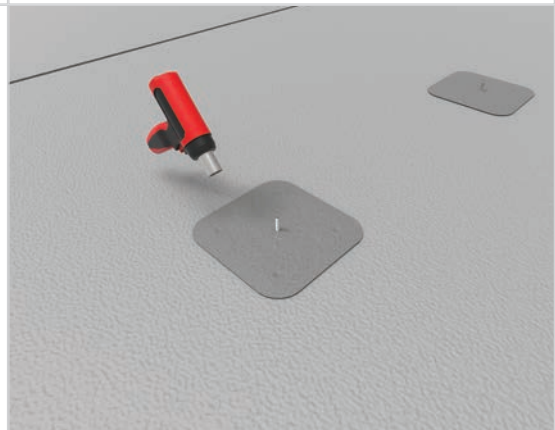

4. Cover the SPM3 plate with the prepared membrane and start the installation with a manual welding machine. Once the holes are welded, weld all sides around the SPM3 plate
5. The SPM3 plate glued to the membrane is a basis for a structure for PV Installations

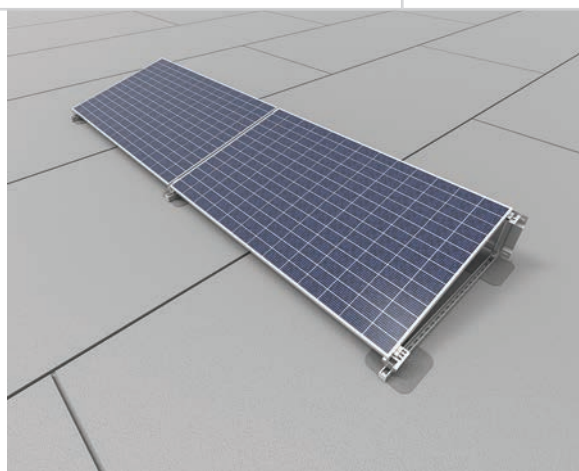

6. Correctly installed structure using SPM3 plate and DP-DNHWE mounting system

Bottom profile	PDTSMC	mat.: MC	quantity per package [pcs.]
symbol	catalogue number	dimension L [mm]	
PDTSMC	954500	1970	1

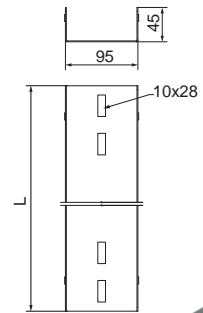

Use:
Lower profile of a south-facing triangular structure on a flat roof.

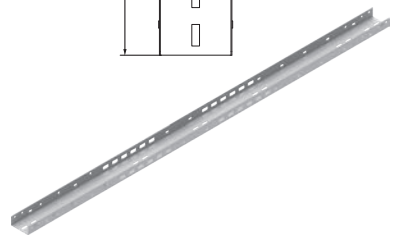

Bottom profile	PDTSWZMC	mat.: MC	quantity per package [pcs.]
symbol	catalogue number	dimension L [mm]	
PDTSWZMC	954600	2815	1

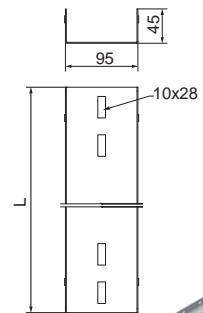

Use:
Lower profile of a triangular structure with an east-west orientation for a flat roof.

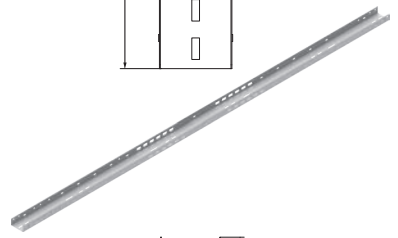

Top profile	PGTSMC	mat.: MC	quantity per package [pcs.]
symbol	catalogue number	dimension L [mm]	
PGTSMC	924200	1829	1

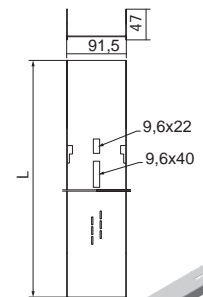

Use:
The upper profile of a south-facing triangular structure on a flat roof.

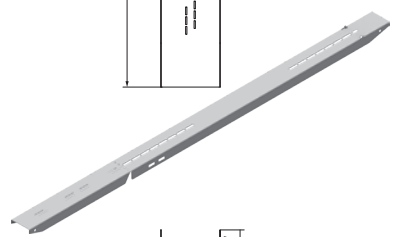

Top profile	PGTSWZMC	mat.: MC	quantity per package [pcs.]
symbol	catalogue number	dimension L [mm]	
PGTSWZMC	954300	2568	1

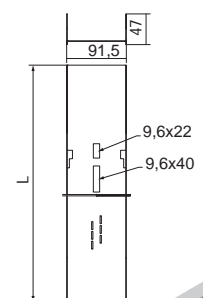

Use:
The upper profile of a triangular structure with an east-west orientation for a flat roof.

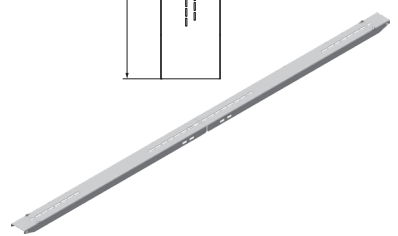

Structures for mounting photovoltaic panels - mounting elements

Channel base with vibro-insulating rubber

PC... mat.: MC

symbol	catalogue number	dimension a [mm]	weight 1 pc. [kg]	quantity per package [pcs.]
PC50P	858434	50	0.08	10
PC100J	858435	100	0.16	10
PC100P	858432	100	0.16	10
PC100C	858433	100	0.16	10

N STM

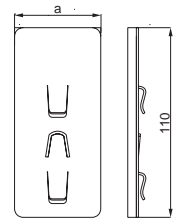

Use:

The stand separates the load-bearing profile of the structure for a flat roof from the roof sheathing preventing damage to the sheathing during assembly and operation of the structure.

Additional information:

- screwless mounting
- easy and quick mounting
- the stand is equipped with vibration insulating rubber
- note!

the PC50P channel base fits 1.2 - 1.5 mm sheet metal.
 the PC100J channel base fits 0.7 - 1.0 mm sheet metal.
 the PC100P channel base fits 1.2 - 1.5 mm sheet metal.
 the PC100C channel base fits 2.0 mm sheet metal.

Side Holder

BUFMC mat.: MC

symbol	catalogue number	weight 1 pc. [kg]	quantity per package [pcs.]
BUFMC	897334	0.09	10

N STM

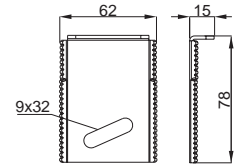

Use:

Mounting PV panels to aluminium profiles, channels and brackets.

Additional information:

- an oblique opening 9x32 allows the installation of panels with a height of the frame in the range of 30-40 mm
- quick assembly thanks to the use of a screw with a rhombus nut, which locks in the CC50H35MC channel
- thanks to the side bends, the clamp ensures continuity between the panel frame and the structure

A - Installation of the CMP41H41 ... MC channel to the base of the PCSBV
 B - Mounting of the BUFMC clamp to the CC50H35 ... MC channel

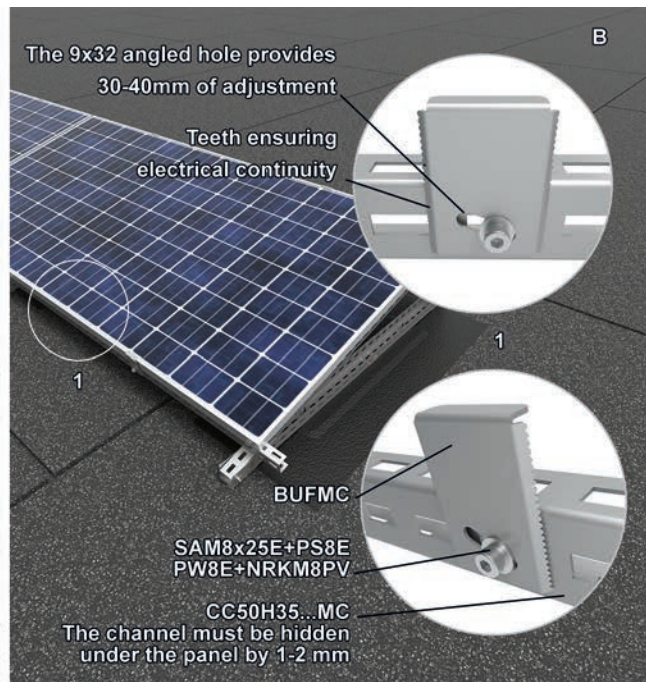
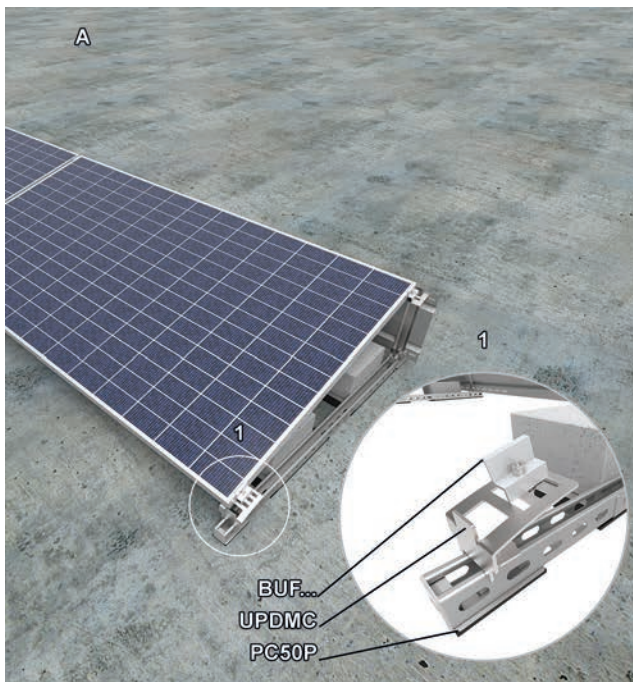

Holder - Bottom	UPDMC	mat.: MC		
symbol	catalogue number	weight 1 pc. [kg]	quantity per package [pcs.]	
Material thickness = 3.0 mm				
UPDMC	857016	0.25	30	

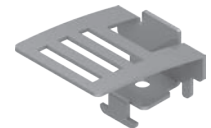
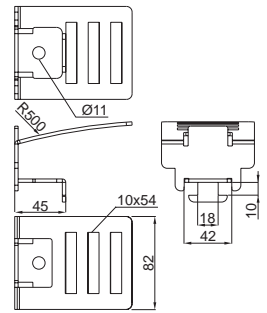

Use:

Mounting PV panels on flat roofs.

Additional information:

- longitudinal holes for mounting panels give the possibility to move in case of unevenness of the substrate to which the structure is mounted
- allows infinite adjustment of the spacing of the brackets under the panel
- mounting bracket to the channel with a single bolt with a channel nut
- easy and quick mounting
- high strength parameters
- visually pleasant installation
- universal holder for 3 panel fixing angles
- universalhalter für 3 Winkel Einstellung
- for the assembly use 1 x SGKFM10x30F Screw Sets

Assembly of UPDMC Panel's Bottom Holder and UPG...MC Panel's Top Holder

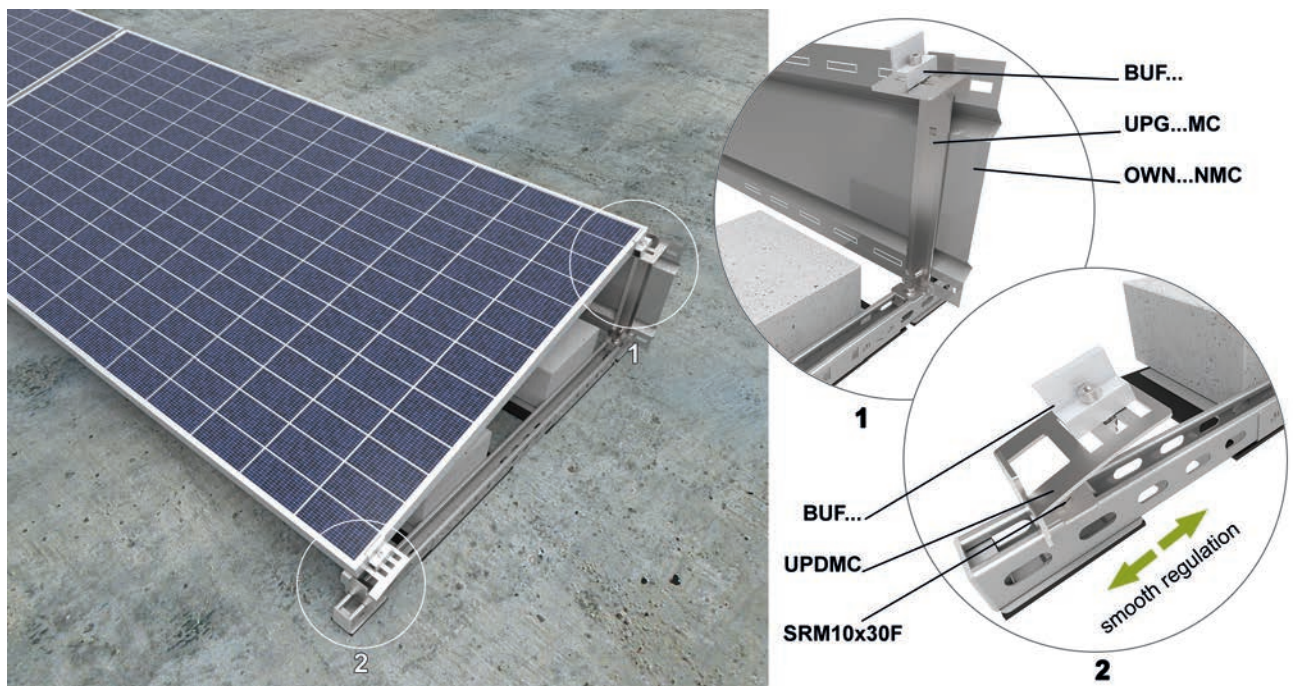

MC - steel in Magnelis® coating

Holder - Top

UPG...MC

mat.: MC

symbol	catalogue number	dimension H [mm]	weight 1 pc. [kg]	quantity per package [pcs.]
--------	------------------	------------------	-------------------	-----------------------------

Material thickness = 3.0 mm

UPG10MC	878110	225	0.41	12
UPG15MC	878115	306	0.50	10
UPG20MC	878120	398	0.60	8

Use:

Mounting PV panels on flat roofs.

Additional information:

- longitudinal holes for mounting panels give the possibility to move in case of unevenness of the substrate to which the structure is mounted
- allows infinite adjustment of the spacing of the brackets under the panel
- mounting bracket to the channel with a single bolt with a channel nut
- easy and quick mounting
- high strength parameters
- visually pleasant installation
- universal holder for 3 panel fixing angles
- for the assembly use 1 x SGKFM10x30F Screw Sets

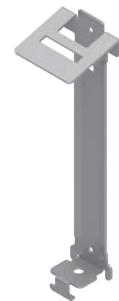
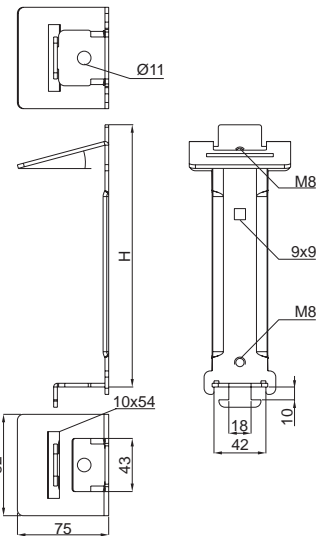

Assembly of UPDMC Panel's Bottom Holder and UPG...MC Panel's Top Holder

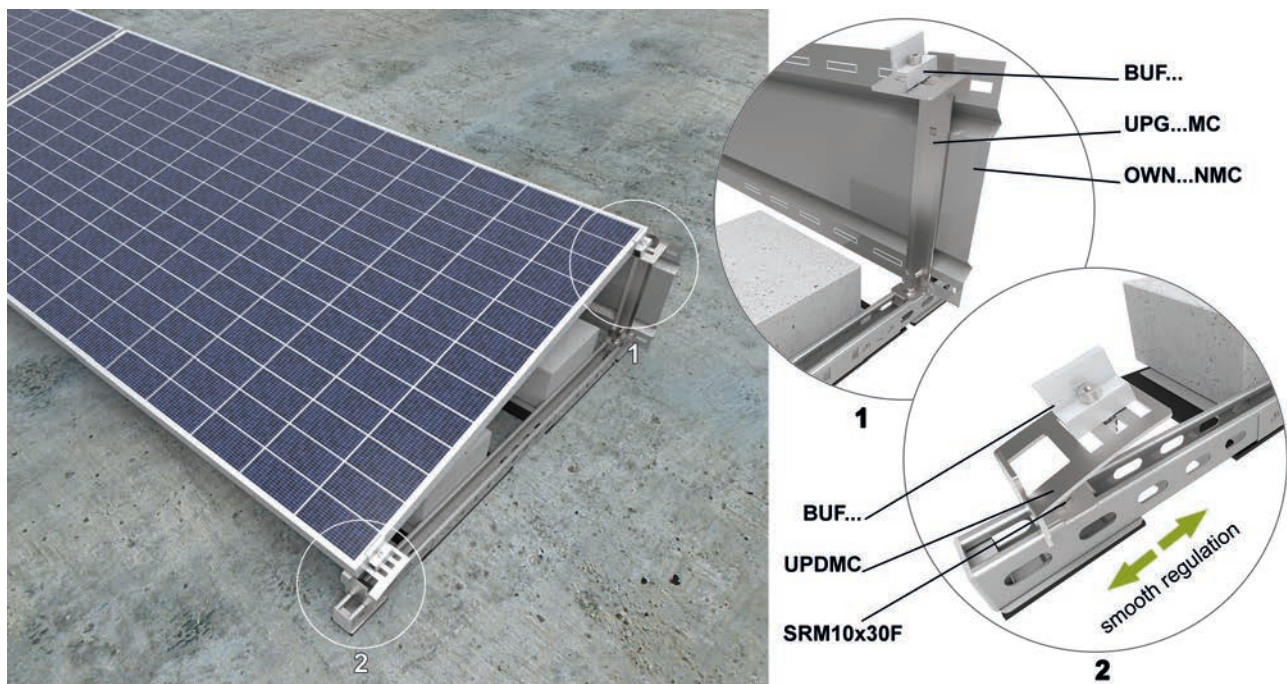

MC - steel in Magnelis® coating

Structures for mounting photovoltaic panels - mounting elements

Upper base east-west	PGWZMC	mat.: MC		
symbol	catalogue number	weight 1 pc. [kg]	quantity per package [pcs.]	
Material thickness = 2.0 mm				
PGWZMC	878000	0.17	10	

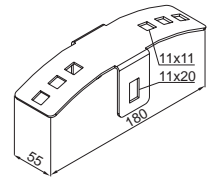

Use:
Mounting to the vertical, center profile in an east-west construction, allows screwing the other profiles at the right angle.

Additional information:

- easy and quick mounting
- high strength parameters
- universal application for structures with tilt angled panels 10°, 15° or 20°
- for the assembly use 1 x SMM10x70F + PP10F + 2 x SGKFM10x20PV Screw Sets

Spacer	BR45/1MC	mat.: MC		
symbol	catalogue number		quantity per package [pcs.]	
Material thickness = 1.0 mm				
BR45/1MC	7041455		50	

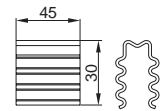

Use:
As a spacer to prevent the fitting from crushing during bolting. For channels

Additional information:

- special profiling strengthens the element, prevents entry into the light of the profile perforation when tightening fastening screws and increases the contact surface of the strut plate with the inner surfaces of the profile
- the BR45/1MC Spacer fits the CC50H35...MC channel

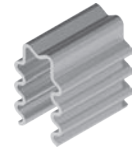

1 - Installation of the PGWZMC east-west upper base with the BR45/1MC expansion plate to the channel

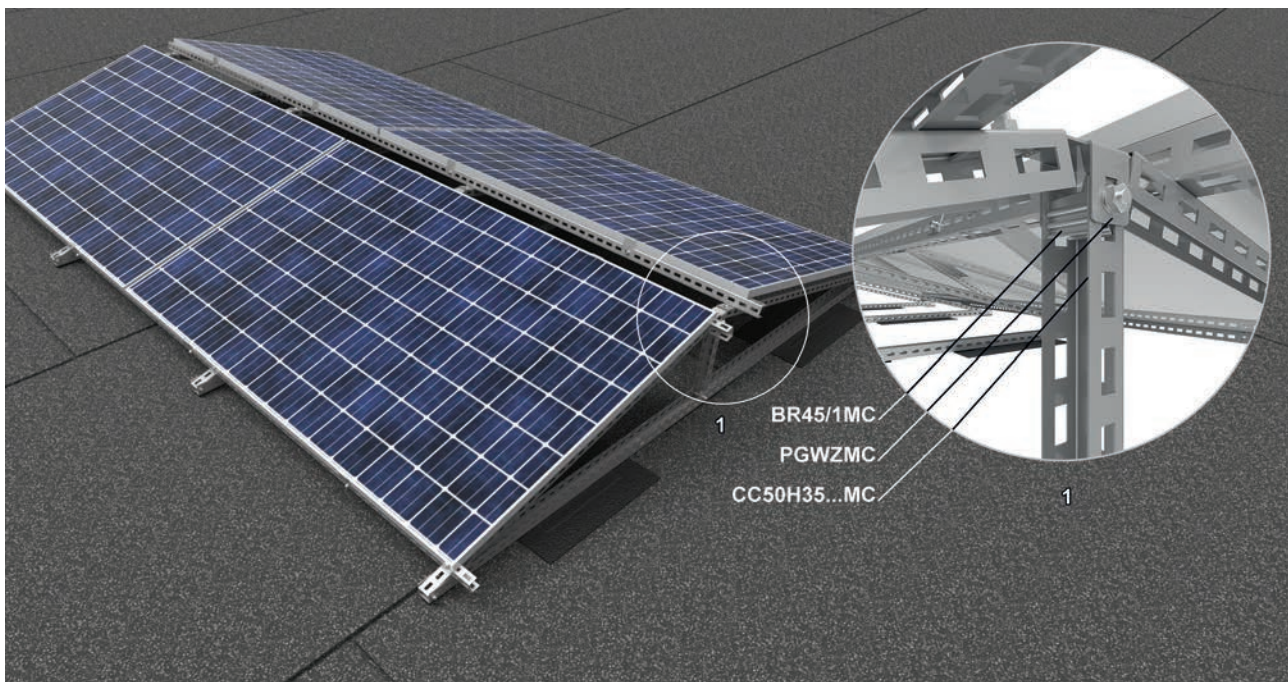

Ballast base		PBK...MC	mat.: MC		
symbol	catalogue number	dimension H/L [mm]	weight 1 pc. [kg]	quantity per package [pcs.]	STM
PBK40MC	858440	40/240	0.78	10	
PBKJ40MC	858442	40/478.5	1.45	10	
PBKD40MC	858441	40/478.5	1.45	10	
PBK50MC	858450	50/240	0.81	10	
PBKD50MC	858451	50/478.5	1.48	10	

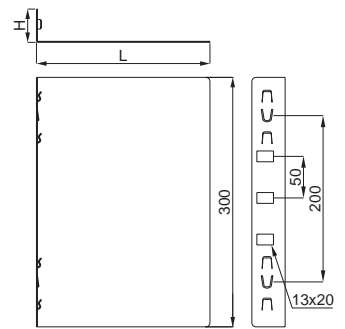

Use:

Laying the ballast and ballasting the structure.

Additional information:

- overall dimensions adjusted to the most popular sizes of concrete blocks
- quick and easy mounting without tools
- additional fastening with SGKFM10x20PV bolts is possible

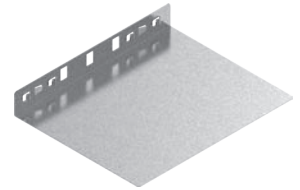

Sleeper padding		SBV...	mat.: WG		
symbol	catalogue number	dimension a/L [mm]	weight 1 pc. [kg]	quantity per package [pcs.]	STM
Material thickness = 10.0 mm					
SBV50x100	895500	50/100	0.18	50	
SBV50x500	895501	50/500	0.90	50	
SBV250x350	895507	250/350	0.32	30	



Sleeper padding		SBR...	mat.: WG		
symbol	catalogue number	dimension a/L [mm]	weight 1 pc. [kg]	quantity per package [pcs.]	ST
Material thickness = 10.0 mm					
SBR50x500	890001	50/500	0.18	50	
SBR150x500	890002	150/500	0.55	50	
SBR250x350	890007	250/350	0.64	50	



Use:

Separation between the elements of the support structure and the roof sheathing.

Additional information:

- special rubber that absorbs vibrations and does not absorb water
- dimensions adapted to elements of BAKS structures

1 - Assembly of DP-DNHBE structure using the PBK40MC Base Plate and SB... Vibration Damping Rubber

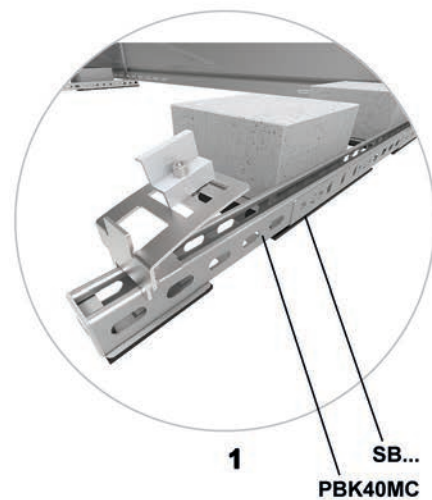
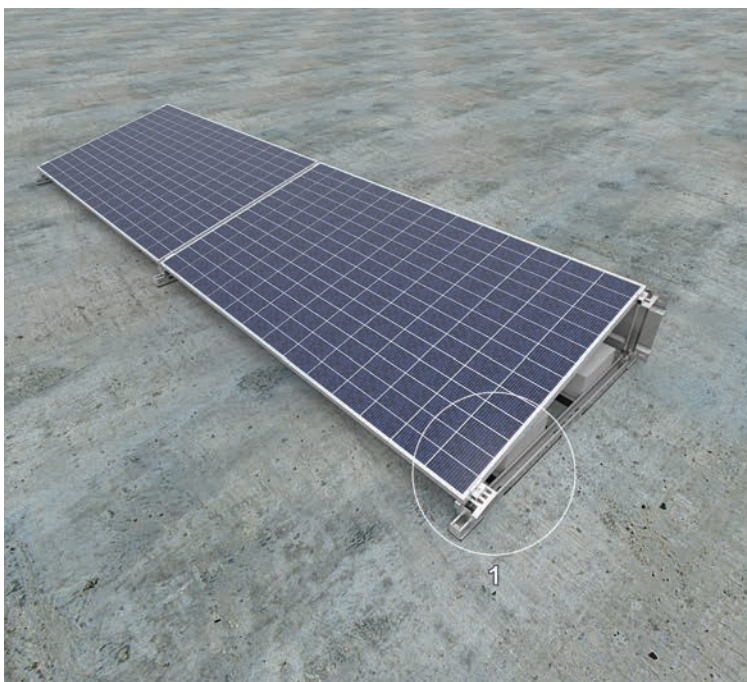

Structures for mounting photovoltaic panels - mounting elements

CLICK ballast base with height adjustment SKR41MC mat.: MC

symbol	catalogue number	weight 1 pc. [kg]	quantity per package [pcs.]
Material thickness = 1.5 mm			
SKR41MC	856031	0.26	10

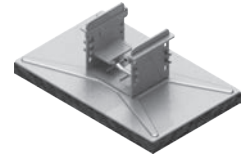
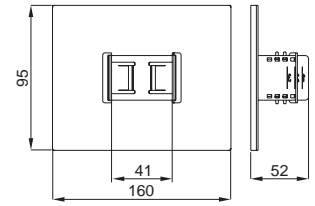

Use:
Installation in the lower structural profile to separate and lift metal elements from the roof surface and to secure the structure using ballast. Height adjustment of the lower profile is possible in three positions: 19, 26, 33 mm.

Additional information:

- overall dimensions adjusted to the most popular sizes of concrete blocks
- quick and easy mounting without tools
- base with bonded vibration-damping rubber prevents damage to the roof covering
- overall dimensions adjusted to the most popular sizes of concrete blocks
- quick and easy mounting without tools
- base with bonded vibration-damping rubber prevents damage to the roof covering

CLICK ballast base with height adjustment SKR95MC mat.: MC

symbol	catalogue number	weight 1 pc. [kg]	quantity per package [pcs.]
Material thickness = 1.5 mm			
SKR95MC	856028	0.33	10

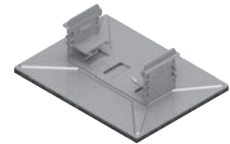
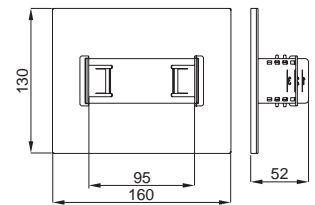

Use:
Installation in the lower structural profile to separate and lift metal elements from the roof surface and to secure the structure using ballast. Height adjustment of the lower profile is possible in three positions: 19, 26, 33 mm.

Additional information:

- overall dimensions adjusted to the most popular sizes of concrete blocks
- quick and easy mounting without tools
- base with bonded vibration-damping rubber prevents damage to the roof covering
- overall dimensions adjusted to the most popular sizes of concrete blocks
- quick and easy mounting without tools
- base with bonded vibration-damping rubber prevents damage to the roof covering

A – Example of installing the SKR95MC ballast base with height adjustment to a profile
B – Example of installing the SKR41MC ballast base with height adjustment to a channel

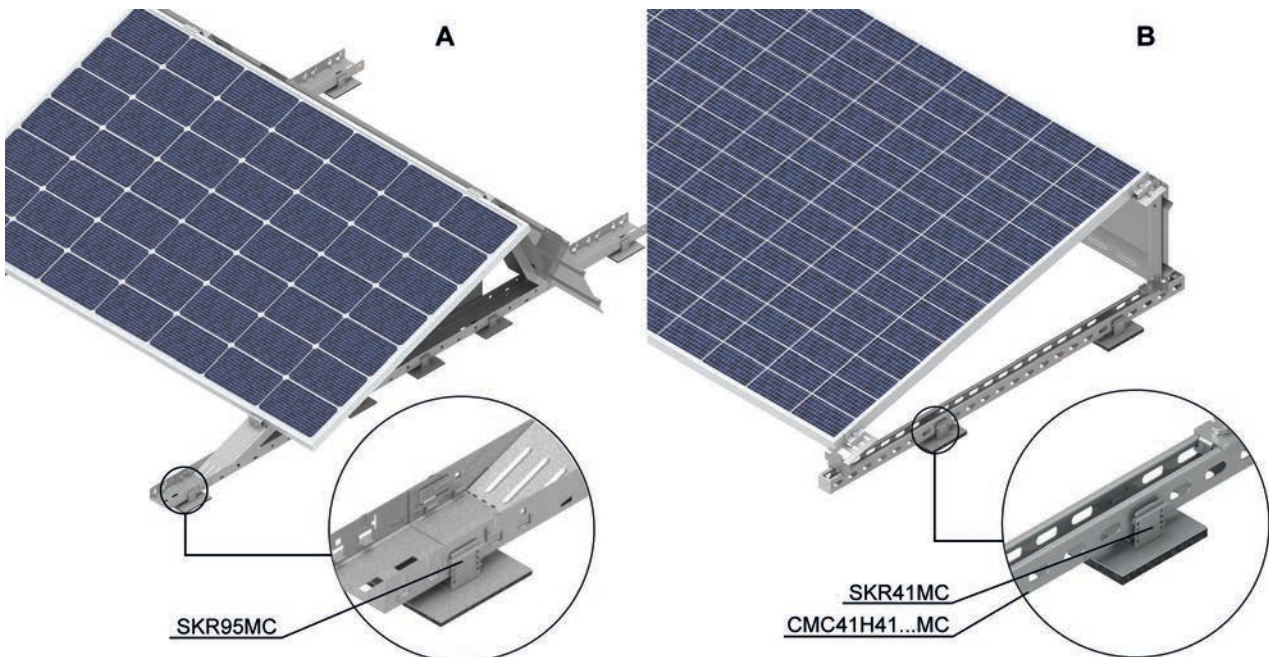

CLICK ballast base with height adjustment SKRB41MC mat.: MC

symbol	catalogue number	weight 1 pc. [kg]	quantity per package [pcs.]
SKRB41MC	858457	0.49	10

N **STM**

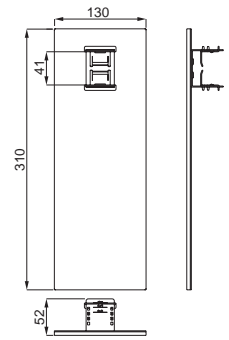

Use:

Installation in the lower structural profile to separate and lift metal elements from the roof surface and to secure the structure using ballast. Height adjustment of the lower profile is possible in three positions: 19, 26, 33 mm.

Additional information:

- overall dimensions adjusted to the most popular sizes of concrete blocks
- quick and easy mounting without tools
- base with bonded vibration-damping rubber prevents damage to the roof covering
- overall dimensions adjusted to the most popular sizes of concrete blocks
- quick and easy mounting without tools
- base with bonded vibration-damping rubber prevents damage to the roof covering

CLICK ballast base with height adjustment SKRB95MC mat.: MC

symbol	catalogue number	weight 1 pc. [kg]	quantity per package [pcs.]
SKRB95MC	858456	0.71	10

N **STM**

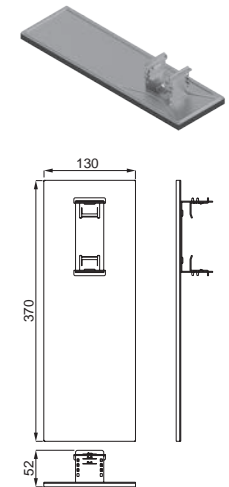

Use:

Installation in the lower structural profile to separate and lift metal elements from the roof surface and to secure the structure using ballast. Height adjustment of the lower profile is possible in three positions: 19, 26, 33 mm.

Additional information:

- overall dimensions adjusted to the most popular sizes of concrete blocks
- quick and easy mounting without tools
- base with bonded vibration-damping rubber prevents damage to the roof covering
- overall dimensions adjusted to the most popular sizes of concrete blocks
- quick and easy mounting without tools
- base with bonded vibration-damping rubber prevents damage to the roof covering

A – Example of installing the SKRB95MC ballast base with height adjustment to a channel
 B – Example of installing the SKRB41MC ballast base with height adjustment to a profile

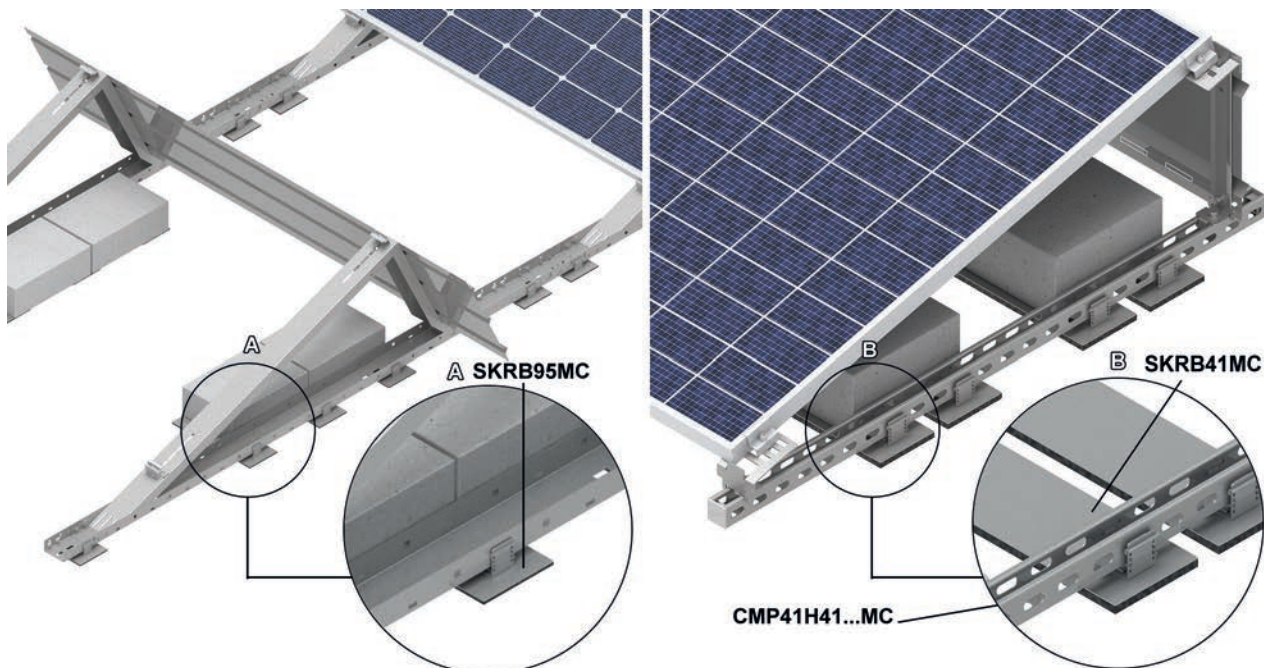

Structures for mounting photovoltaic panels - mounting elements

Wind Shield	OWN.../...NMC	mat.: MC		
symbol	catalogue number	dimension H/L [mm]	weight 1 pc. [kg]	quantity per package [pcs.]
Material thickness = 0.5 mm				
OWN10/1,8NMC	8510185	235/1800	1.90	5
OWN10/2,12NMC	8510215	235/2120	2.40	5
OWN10/2,40NMC	8510245	235/2400	3.00	5
OWN15/1,8NMC	8515185	316/1800	2.20	5
OWN15/2,12NMC	8515215	316/2120	2.90	5
OWN15/2,40NMC	8515245	316/2400	3.60	5
OWN20/1,8NMC	8520185	401/1800	3.30	5
OWN20/2,12NMC	8520215	401/2120	3.50	5
OWN20/2,40NMC	8520245	401/2400	4.10	5
OWN20/2,60NMC	8520275	401/2600	4.50	5

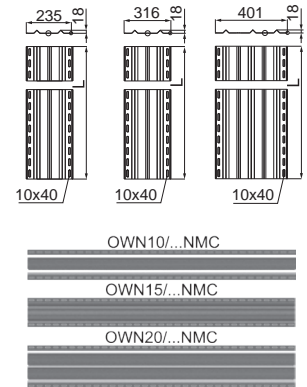

Use:

Installation for flat-roof structures with panel tilt angles of 10°, 15°, or 20° to improve aerodynamic performance and reduce ballast weight; covers are compatible with UPG...MC brackets with M8 threaded holes

Additional information:

- special embossing to strengthen and stiffen the covers
- specially designed cut-outs allowing to break out hole plugs without leaving sharp edges in the product
- dense perforation allowing to mount the cover to the construction with different panels
- special break-out cut-outs for simple screwing on covers for panel top brackets
- mounting to the UPG...MC holder using SSZ8X12E + PW8E + PS8E
- mounting to the CP50H35/...MC channel using SAM8x25E + PS8E + PW8E + NRKM8PV
- the PW8E washer should be used between the OWN.../...NMC wind shield and the UPG...MC holder

Assembly of DP-DNHBE construction using a OWN.../...NMC wind shield



Instructions for the installation of wind shields in DP - DNH...N structures

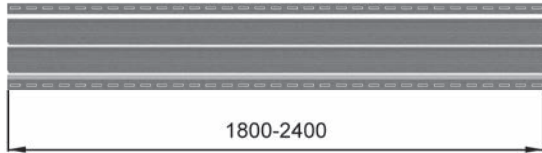

1. The length of the covers is selected based on: panel length + 60 mm.

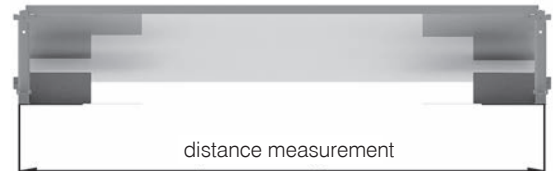

2. Measure the distance between the axes of the UPG...MC brackets to which the panel is mounted.

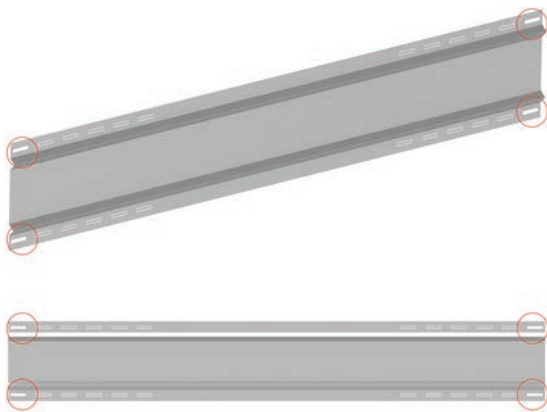

3. Using a flat screwdriver, break out the holes in the cover that align with the UPG...MC holder holes from step 2.

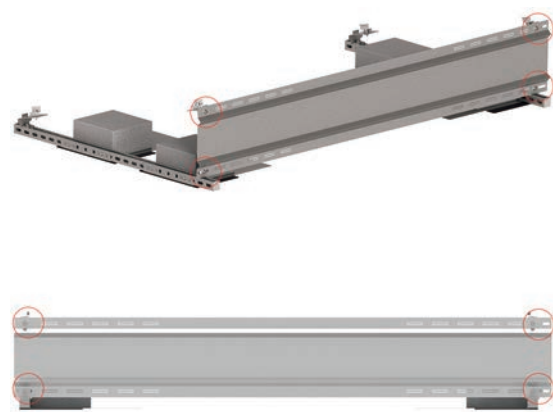

4. Place the cover on the UPG...MC brackets and tighten it with M8 screws into the threaded holes in the brackets.

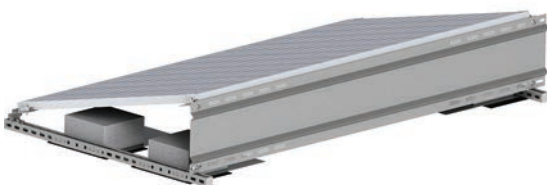

5. Cover installed.

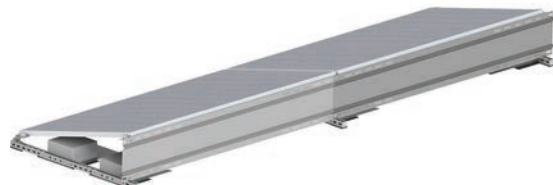

6. When installing a series of panels, secure adjacent covers with common M8 screws, repeating steps 3 and 4.



Roof fixing - adjustable	DUR40E	mat.: E	quantity per package [pcs.]
symbol	catalogue number	weight 1 pc. [kg]	
DUR40E	898140	1.05	20

STM

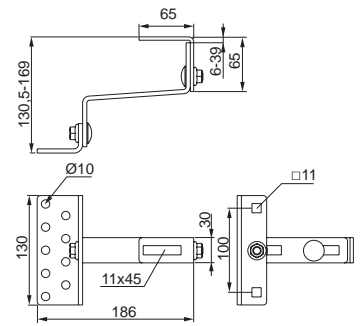

Use:
Connecting photovoltaic panels to support free standing structures.

- Additional information:**
- adjustable bracket for ceramic tiled roof
 - large range of adjustment in two planes
 - 9 holes in the base allow trouble-free mounting to the rafters
 - for the assembly use: min. 2 x DDW8x100 Wood Screws



Roof fixing	DURSE	mat.: E	quantity per package [pcs.]
symbol	catalogue number	weight 1 pc. [kg]	
DURSE	898141	0.84	20

STM

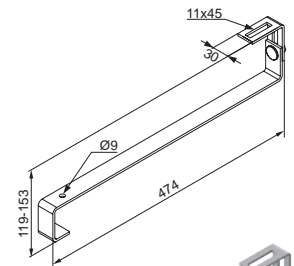

Use:
Connecting photovoltaic panels to support free standing structures.

- Additional information:**
- adjustable bracket for ceramic tiled roof
 - large range of adjustment
 - installation to roof truss battens
 - for the assembly use 1 x DDW6x60E Wood Screw

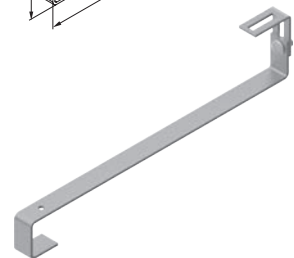

A - Assembly of DUR40E Adjustable Roof Fixing to the rafter with DDW8x100 Wood Screws
B - Assembly of DURSE Adjustable Roof Fixing to the rafter with DDW6x60E Wood Screws

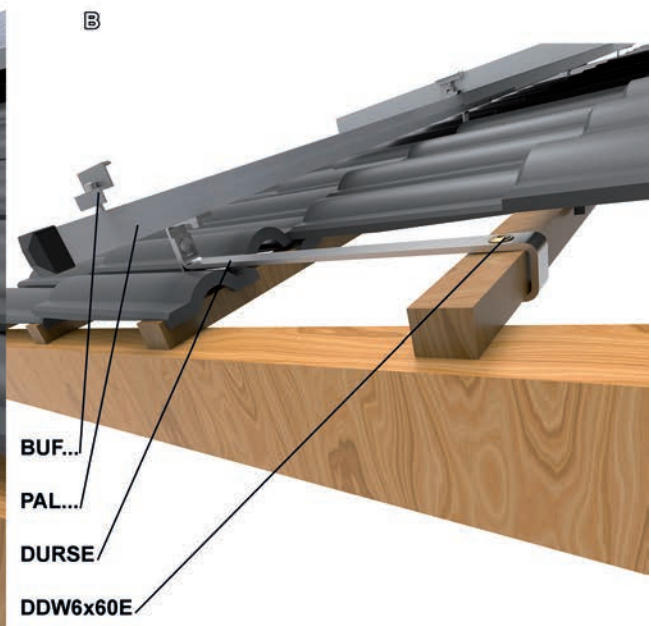
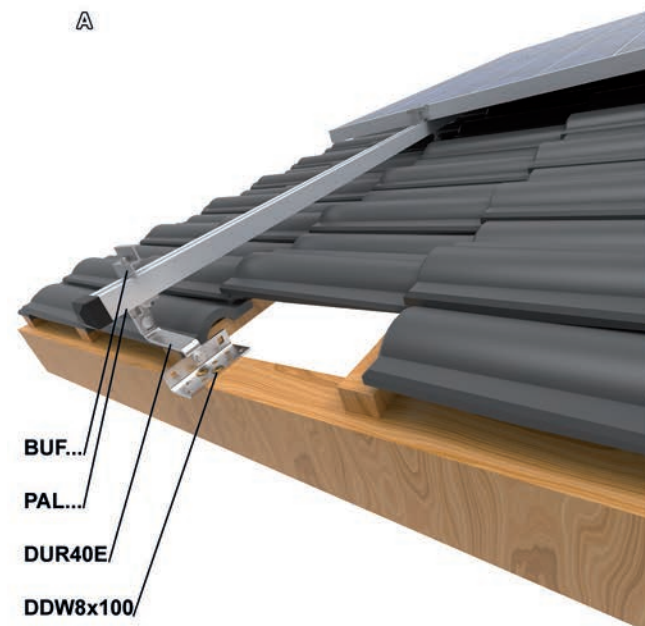

Roof fixing	DUF60E	mat.: E	quantity per package [pcs.]
symbol	catalogue number	weight 1 pc. [kg]	
DUF60E	897960	0.25	20

STM

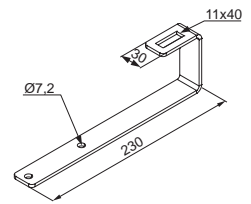

Use:
Mounting PV structure elements to a roof covered with bituminous tiles.

Additional information:

- longitudinal hole for adjusting the position of the aluminium profile
- extended longer arm to make screwing easier
- for the assembly use 2 x DDW6x60E Wood Screws



Roof fixing	DUFR60E	mat.: E	quantity per package [pcs.]
symbol	catalogue number	weight 1 pc. [kg]	
DUFR60E	897860	0.39	20

STM

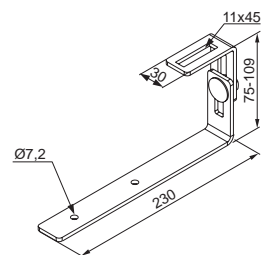

Use:
Mounting PV structure elements to a roof covered with bituminous tiles.

Additional information:

- height adjustment of the upper element allows to level the holders and compensate for unevenness on the roof
- longitudinal hole for adjusting the position of the aluminium profile
- extended longer arm to make screwing easier
- for the assembly use 2 x DDW6x60E Wood Screws



A - Assembly of the DUF60E Roof Fixing to the rafter with DDW6x60E Wood Screws
B - Assembly of the DUFR60E Adjustable Roof Fixing to the rafter with DDW6x60E Wood Screws

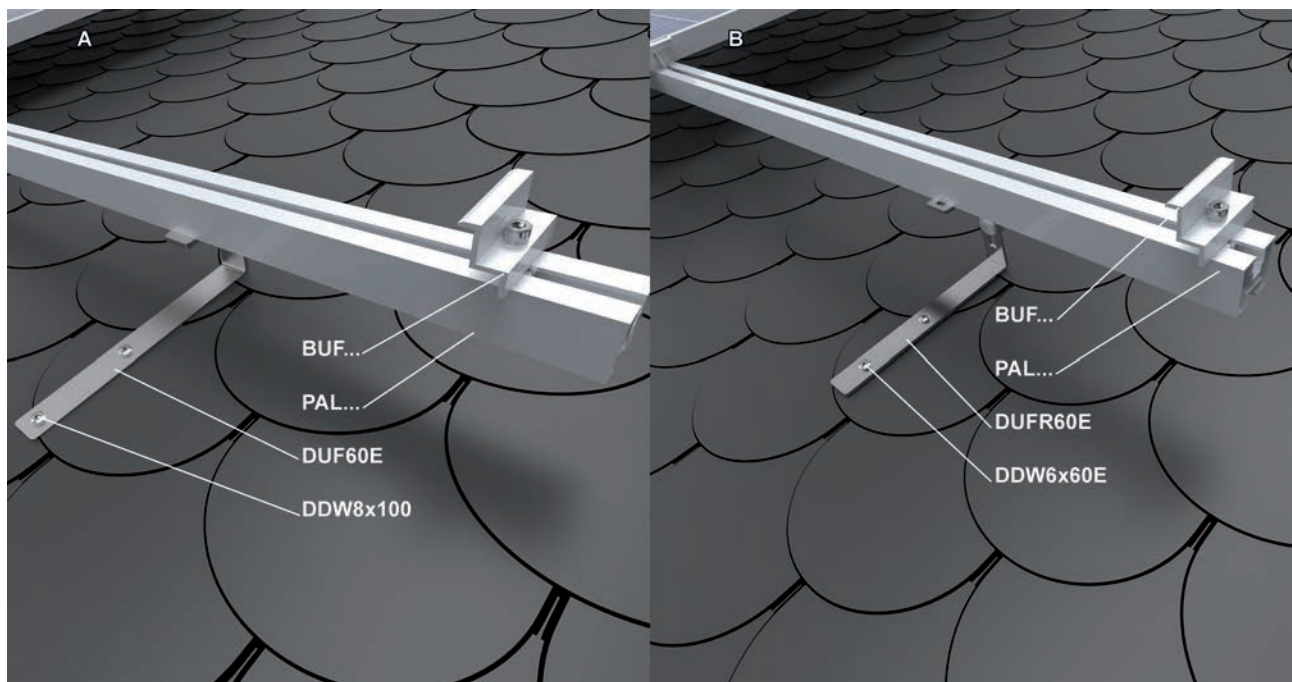

Roof fixing	DUF75E	mat.: E	quantity per package [pcs.]
symbol	catalogue number	weight 1 pc. [kg]	
DUF75E	897975	0.30	20

STM

Use:
Mounting PV structure elements to a roof covered with scale-shaped tiles.

Additional information:

- length suitable for most types of tiles
- longitudinal hole for adjusting the position of the aluminium profile
- for the assembly use: min. 2 x DDW8x100 Wood Screws

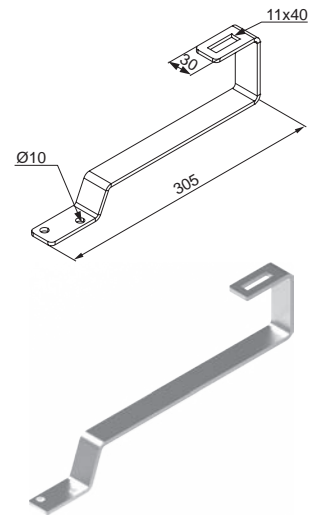

Roof fixing	DUFR75E	mat.: E	quantity per package [pcs.]
symbol	catalogue number	weight 1 pc. [kg]	
DUFR75E	897965	0.45	20

STM

Use:
Mounting PV structure elements to a roof covered with scale-shaped tiles.

Additional information:

- height adjustment of the upper element allows to level the holders and compensate for unevenness on the roof
- length suitable for most types of tiles
- longitudinal hole for adjusting the position of the aluminium profile
- for the assembly use: min. 2 x DDW8x100 Wood Screws

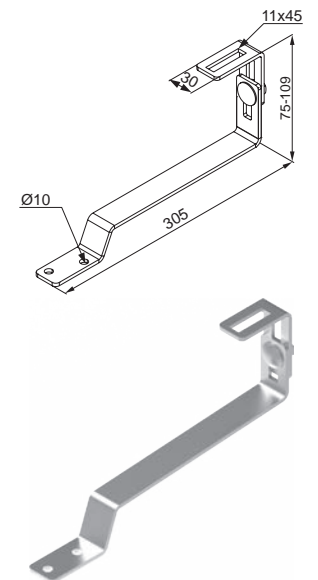

A - Assembly of the DUF75E Roof Fixing to the rafter with DDW8x100 Wood Screws
B - Assembly of the DUFR75E Adjustable Roof Fixing to the rafter with DDW8x100 Wood Screws

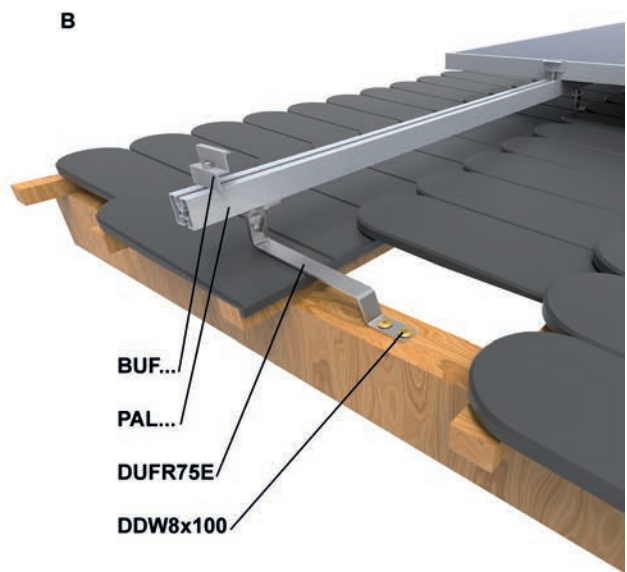
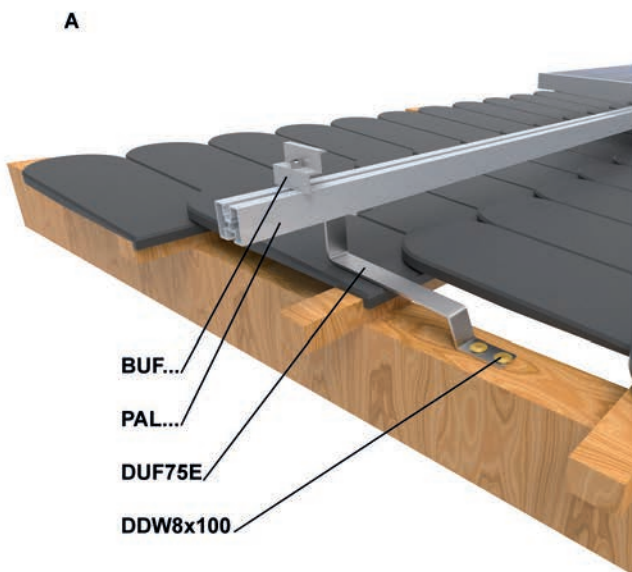



Mounting structures for the Installation of photovoltaic panels - support elements

Roof fixing	DUFPE	mat.: MC	quantity per package [pcs.]
symbol	catalogue number	weight 1 pc. [kg]	
DUFPE	897976	0.30	10

N ST

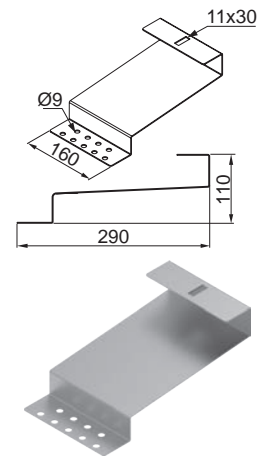

Use:
Mounting PV structure elements to a roof covered with scale-shaped tiles.

Additional information:

- length suitable for most types of tiles
- longitudinal hole for adjusting the position of the aluminium profile
- installation of fixings without the need to saw the tiles
- for the assembly use: min. 2 x DDW8x100 Wood Screws

Roof fixing	DUFWE	mat.: MC	quantity per package [pcs.]
symbol	catalogue number	weight 1 pc. [kg]	
DUFWE	898076	0.30	10

N ST

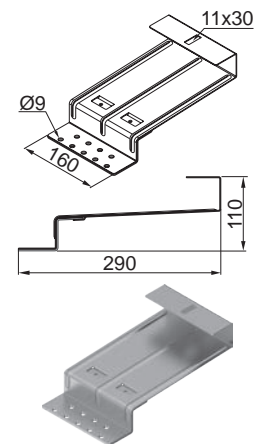

Use:
Mounting PV structure elements to a roof covered with scale-shaped tiles.

Additional information:

- increased strength due to the embossing in the section and the use of an additional Z-profile
- length suitable for most types of tiles
- longitudinal hole for adjusting the position of the aluminium profile
- installation of fixings without the need to saw the tiles
- brackets dedicated for installations exposed to greater loads
- for the assembly use: min. 2 x DDW8x100 Wood Screws

Roof fixing with steel plain tiles	DUF75K...	mat.: MC	quantity per package [pcs.]
symbol	catalogue number	weight 1 pc. [kg]	
DUF75KMC	897855	0.85	1
DUF75KE	897875	0.85	1

ST

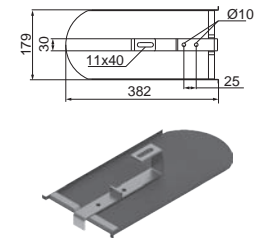

Use:
Mounting aluminium profiles for photovoltaic panels to a plain tile roof.

Additional information:

- no need to mill or cut classic roof tiles
- for the assembly use: min. 2 x DDW8x100E Wood Screws

A - Assembly of DUF75KE Roof Fixing with Scale-Shaped Tile to rafter with DDW8x100E Wood Screws
B - Assembly of DUFPE Roof Fixing to rafter with DDW8x100 Wood Screws

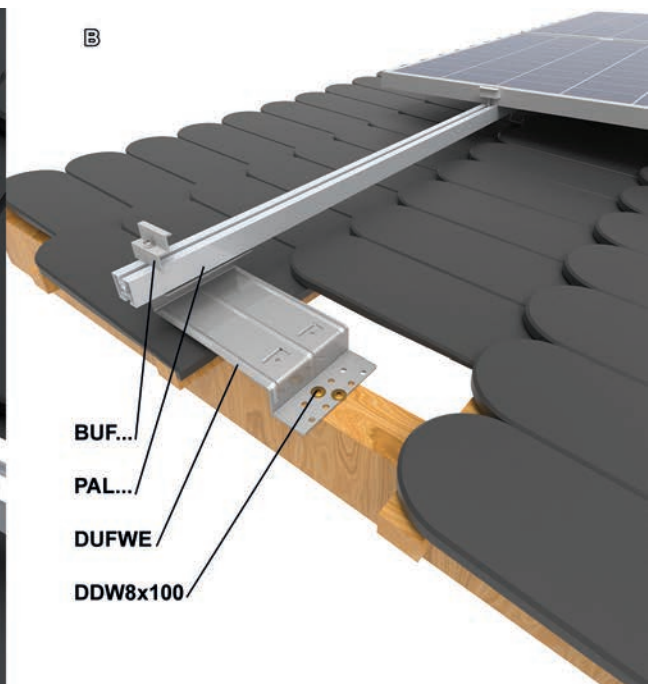

Holder for seam sheet roofing UBZRPE... mat.: E

symbol	catalogue number	dimension H [mm]	weight 1 pc. [kg]	quantity per package [pcs.]
--------	------------------	------------------	-------------------	-----------------------------

STM

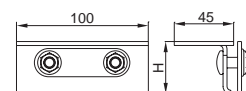

Material thickness = 3.0 mm

UBZRPE25	890125	50	0.43	100
UBZRPE32	890132	55	0.46	100

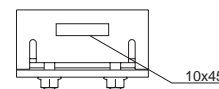

Use:

Mounting PV structure elements to a roof covered with sheet metal seam plates.

Additional information:

- non-invasive roof installation
- quick and stable mounting
- high strength parameters
- visually pleasant installation
- the clamping element of the fixing has a strengthening overpress
- a version of UBZRPE65 and UZBRE65 clamps with height H=65mm available on request



Holder for seam sheet roofing UBZRE... mat.: E

symbol	catalogue number	dimension H [mm]	weight 1 pc. [kg]	quantity per package [pcs.]
--------	------------------	------------------	-------------------	-----------------------------

STM

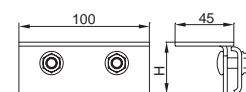

Material thickness = 3.0 mm

UBZRE25	890225	52	0.50	100
UBZRE32	890232	57	0.53	100

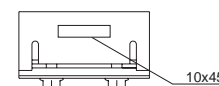

Use:

Mounting PV structure elements to a roof covered with sheet metal seam plates.

Additional information:

- non-invasive roof installation
- quick and stable mounting
- high strength parameters
- visually pleasant installation



CODE	Metal Sheet Manufacturer	Seam height [mm]
UBZRPE25	Balex	25,1
	Budmat	25/27
	Metzink	25 (before folding) 28 (after folding)
	Pruszyński	25
	Wiałal	25
UBZRPE32	Blachdom	32
	Blachotrapez	32
	RUUKKI	32

CODE	Metal Sheet Manufacturer	Seam height [mm]
UBZRE25	Balex	25,1
	Budmat	25/27
	Metzink	25 (before folding) 28 (after folding)
	Pruszyński	25
	Wiałal	25
UBZRE32	Blachdom	32
	Blachotrapez	32
	RUUKKI	32

Assembly of UBZRE... and UBZRPE... Seam Roof Clamps to standing seam metal sheets

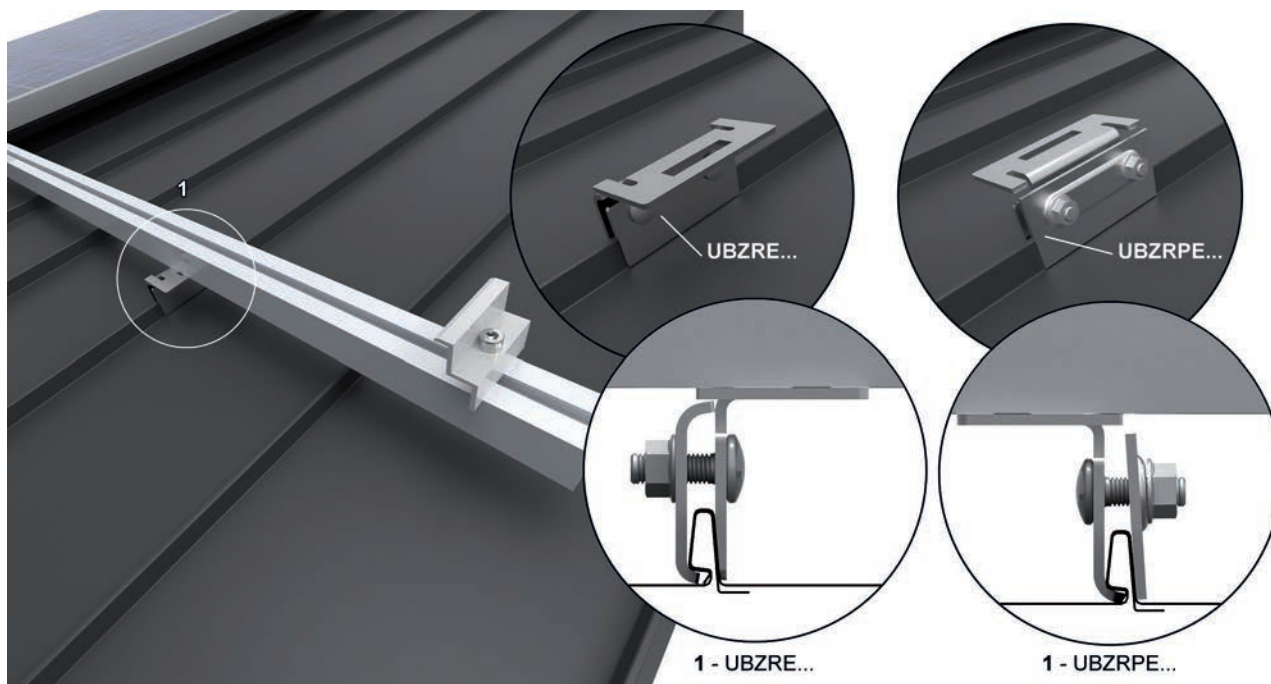

Roof fixing with the trap. sheet- RUBTE adjustable

mat.: E

symbol	catalogue number	weight 1 pc. [kg]	quantity per package [pcs.]
RUBTE	899501	0.50	10

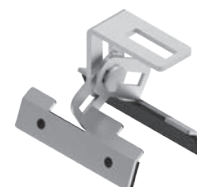
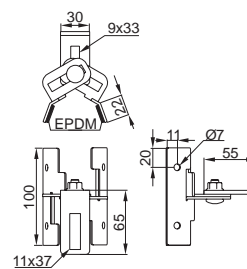

Use:

Mounting PV structure elements to a roof covered with trapezoidal metal sheet.

Additional information:

- fits all types of trapezoidal sheets thanks to the adjustable angle
- wide adjustment range for use with different trapezoidal metal sheets (width from 20 - 85 mm)
- fixing equipped with a EPDM sealing rubber on the underside
- use 4 self-drilling screws SMDP6x25E for mounting

Assembly of RUBTE Roof Fixing to trapezoidal metal sheet

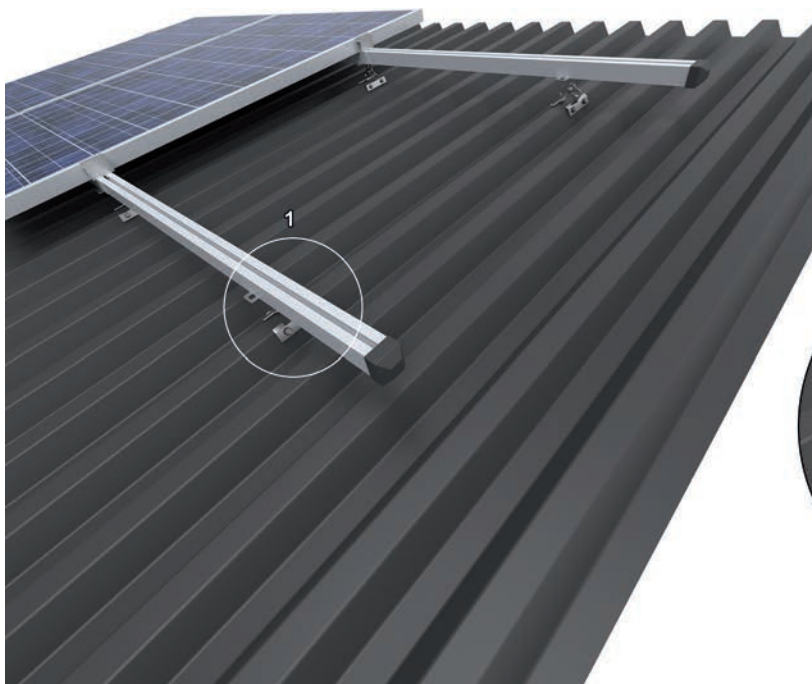

E - stainless steel

Adapter	APPMC	mat.: MC	quantity per package [pcs.]
symbol	catalogue number	weight 1 pc. [kg]	
Material thickness = 2.0 mm			
APPMC	892525	0.41	10

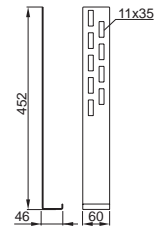

Use:

To support the panel during the installation of construction to the profiles on the elevation and protection against slipping of the installed panel.

Additional information:

- improving the safety of elevation structures and balustrades
- high strength parameters
- for the assembly use 1 x SGKFM10x30F Screw Sets



Installation of PV panels on channels to the wall in the E-VKRN system

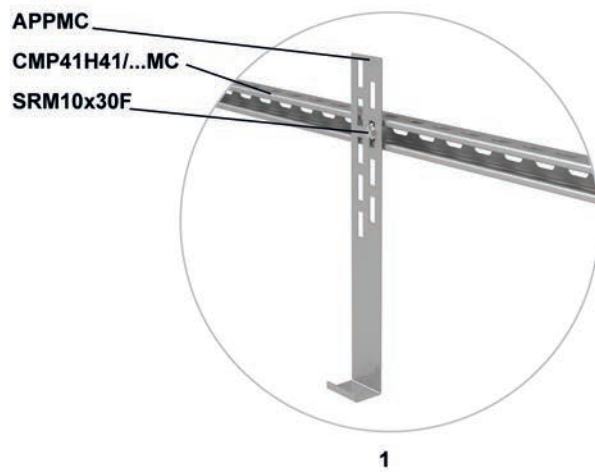
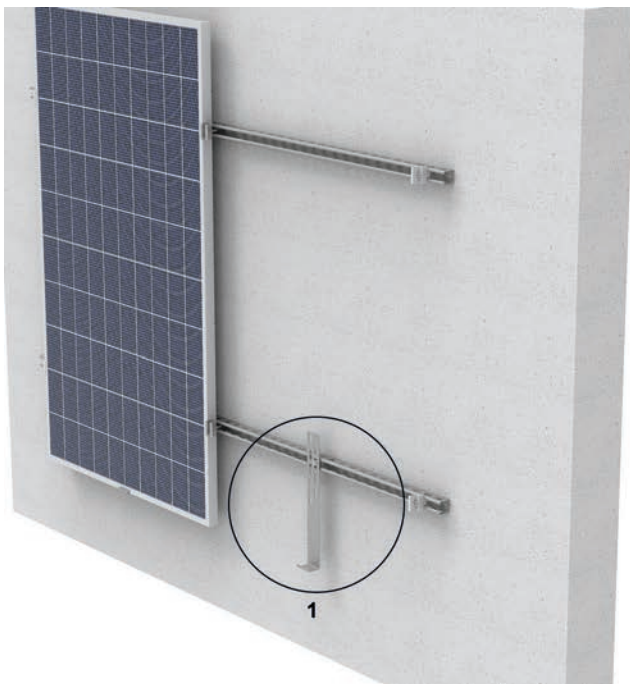

U-bolt	CYB...E	mat.: E		
symbol	catalogue number	dimension a/H [mm]	weight 1 pc. [kg]	quantity per package [pcs.]
CYB16E	899916	18/35	0.02	1
CYB20E	899920	22/39	0.02	1
CYB25E	899925	27/44	0.02	1
CYB32E	899932	34/51	0.02	1
CYB40E	899940	42/59	0.03	1
CYB50E	899950	52/69	0.03	1
CYB60E	899960	62/79	0.03	1
CYB63,5E	899963	65/90	0.04	1

ST

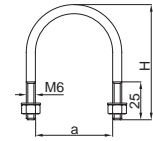

Use:

Fixing the structure to balcony railings with round section.

Additional information:

- the sizes of U-bolts fit most of the profiles of which the balcony railings are made
- quick and easy mounting

U-bolt	CYK...E	mat.: E		
symbol	catalogue number	dimension a/H [mm]	weight 1 pc. [kg]	quantity per package [pcs.]
CYK20E	899820	22/41	0.02	1
CYK25E	899825	27/46	0.02	1
CYK30E	899832	32/51	0.02	1
CYK40E	899840	42/61	0.03	1
CYK50E	899850	52/71	0.03	1
CYK60E	899860	62/81	0.03	1

ST

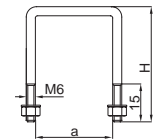

Use:

Fixing the structure to balcony railings with square section.

Additional information:

- the sizes of U-bolts fit most of the profiles of which the balcony railings are made
- quick and easy mounting

Assembly of structure for PV panels to balcony railing with CY...E U-bolts

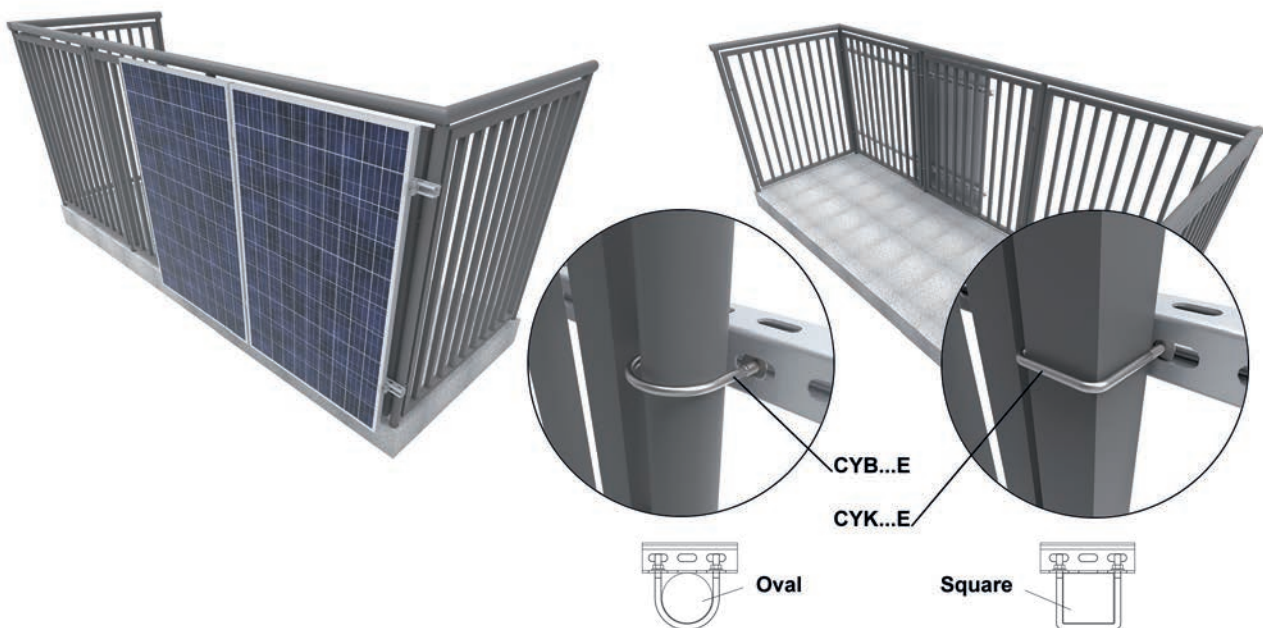

Mounting structures for the Installation of photovoltaic panels - fastening elements

Articulated rod hanger

WPPGTE

mat.: E

symbol	catalogue number	dimension H [mm]	load max. F_{max} [kN]	weight 1 pc. [kg]	quantity per package [pcs.]
--------	------------------	------------------	--------------------------	-------------------	-----------------------------

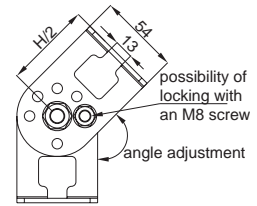

Material thickness = 3.0 mm

WPPGTE	890118	123	3.50	0.41	50
--------	--------	-----	------	------	----

Use:

Creation of PV structures tilted at the angle of a balustrade/facade

Additional information:

- angle adjustment
- for the assembly use SSZ10x20E Screws and NKZM10E Nuts



Channel connector

LCK1ES

mat.: E

symbol	catalogue number	weight 1 pc. [kg]	quantity per package [pcs.]
--------	------------------	-------------------	-----------------------------

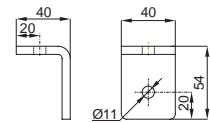

Material thickness = 3.0 mm

LCK1ES	890218	0.15	50
--------	--------	------	----

Use:

Joining PAL 40H40 profiles forming the geometry of the structure

Additional information:

- for the assembly use SSZ10x20E Screws and NKZM10E Nuts



Channel connector

BUU1MC

mat.: MC

option: E

symbol	catalogue number	weight 1 pc. [kg]	quantity per package [pcs.]
--------	------------------	-------------------	-----------------------------

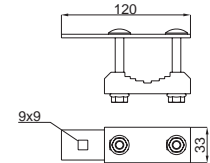

Use:

Mounting the structure to balustrades made of round or square profiles

Additional information:

- bracket adapted to typical balustrade profile widths of 20, 30, 40 mm or pipes with diameters Ø12–50 mm
- longitudinal hole for adjusting the position
- for assembly use the SMH10x25E hammer screw

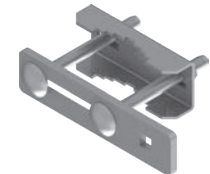

Installation of the structure for PV panels to the balustrade

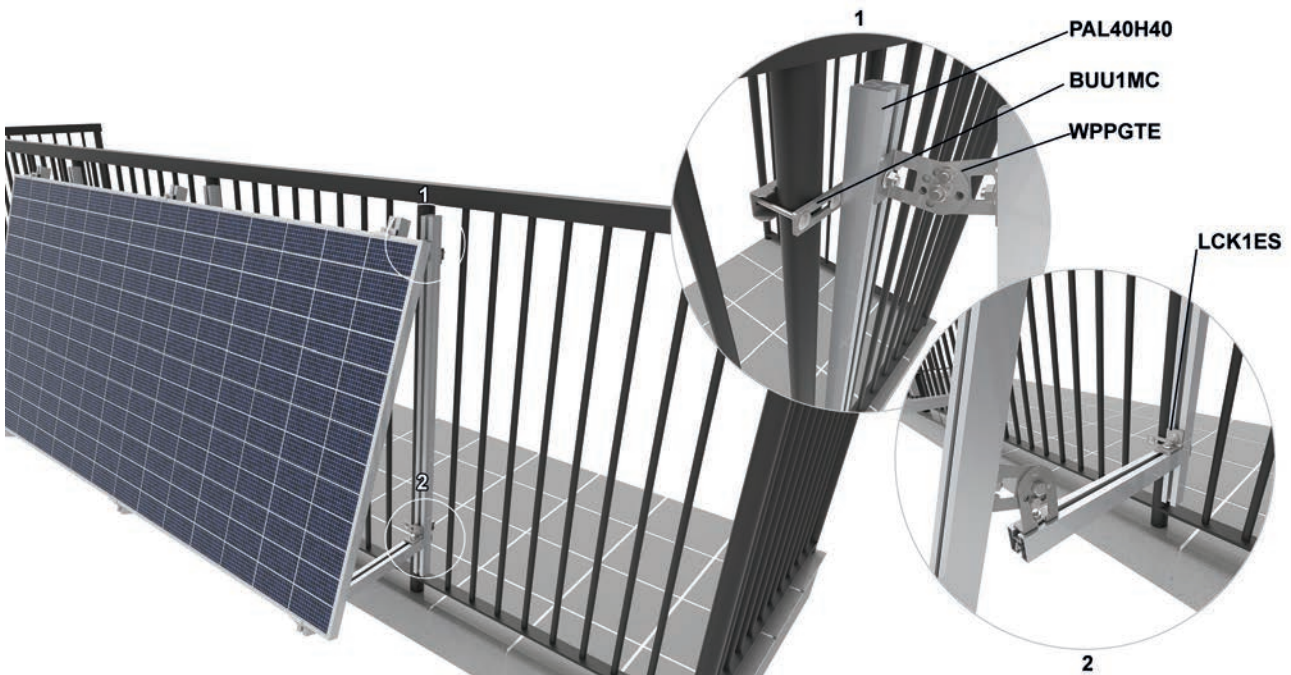

Mounting structures for the Installation of photovoltaic panels - fastening elements

Channel nut NRKM8PV mat.: MC option: E

symbol	catalogue number	quantity per package [pcs.]
NRKM8PV	660246	100

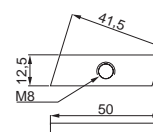

Use:

Assembly of BUFMC holders to CC50H35...MC profiles.

Additional information:

- quick Installation of panel fixing clamps without the need to hold on when tightening the nuts from underneath the structure
- geometry enabling the nut to lock into the profile while tightening
- optimum tightening torque = 12 - 14 Nm

Channel nut NRM8PV mat.: MC option: E

symbol	catalogue number	quantity per package [pcs.]
NRM8PV	660245	100

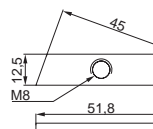

Use:

Assembly of BUF... and PUF holders to CWC100H50... profiles.

Additional information:

- quick Installation of panel fixing clamps without the need to hold on when tightening the nuts from underneath the structure
- geometry enabling the nut to lock into the profile while tightening
- optimum tightening torque = 12 - 14 Nm

Screw SAM8...E mat.: E

symbol	catalogue number	dimension L [mm]	quantity per package
SAM8x20E	898520	20	100
SAM8x25E	898525	25	100
SAM8x30E	898530	30	100
SAM8x35E	898535	35	100
SAM8x40E	898540	40	100
SAM8x45E	898545	45	100

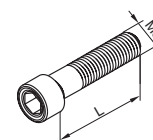

Use:

Fixing screws for aluminium clamps.

Additional information:

- full threads are available in dimensions ≤ 35 mm
- partial threads are available in dimensions ≥ 40 mm

Assembly of panel holders to CWC100H50...NMC Support Channels with NRM8PV Channel Nut

- 1 - Insert the NRM8PV nut fitted onto the SAM8...E screw from above, guiding it parallel to the holes in the profile
- 2 - When the SAM8...E screw is being tightened with an hex key, the NRM8PV nut is locked in the CWC100H50...NMC profile
- 3 - Correctly fitted nut

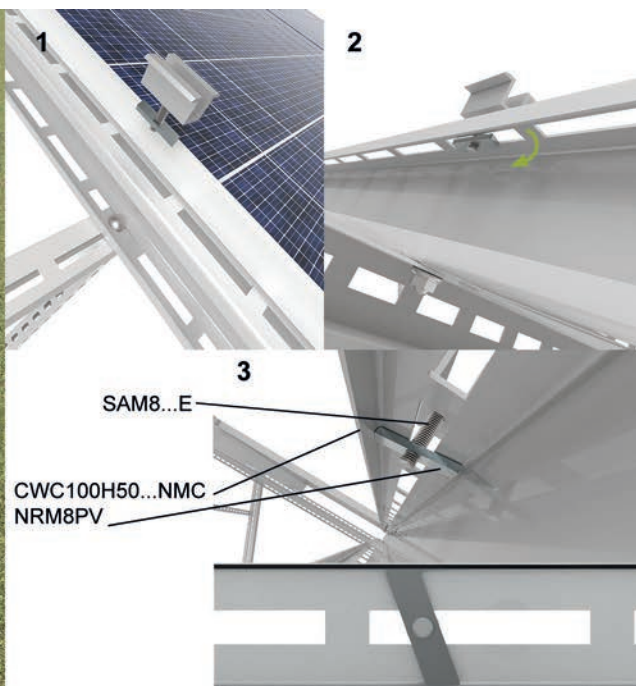
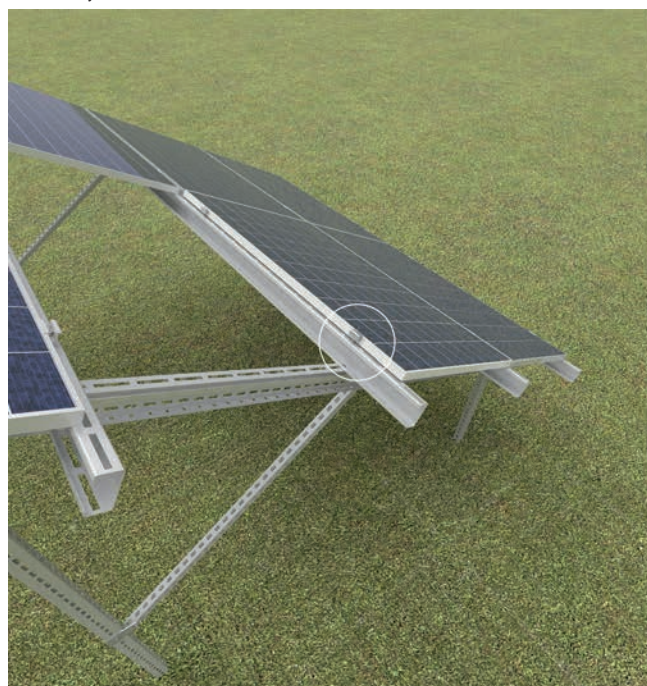

T-screw	SMHM10x...E	mat.: E	quantity per package [pcs.]
symbol	catalogue number	dimension L/M [mm]	
SMHM10x25E	993321	25/10	100
SMHM10x33E	992521	33/10	100

N STM

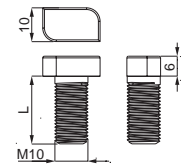

Additional information:

- geometry allowing bolt placement anywhere along the PAL aluminum profile in a 17.5 mm wide slot without sliding along the entire length
- quick and stable installation of PAL... aluminum profiles to roof brackets thanks to bolt locking in the profile slot

Screw	SSZM10x20E	mat.: E	quantity per package [pcs.]
symbol	catalogue number	dimension L/M [mm]	
SSZM10x20E	991020	20/10	100

STM

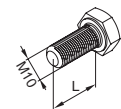

Use:

Mounting structure elements.

Square Nut	NKWM8E	mat.: E	quantity per package
symbol	catalogue number		
NKWM8E	600808		100

STM

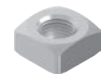
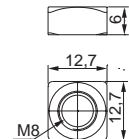

Use:

Mounting structure elements.

Large Washer	PW8F	mat.: FP	quantity per package [pcs.]
symbol	catalogue number	dimension D [mm]	
PW8F	899080	24	100

STM



Use:

Connecting structure elements.

1 - Installation of the PAL40H40 aluminum profile to the AD...E mounting adapter using the SMHM10x25E hammer bolt

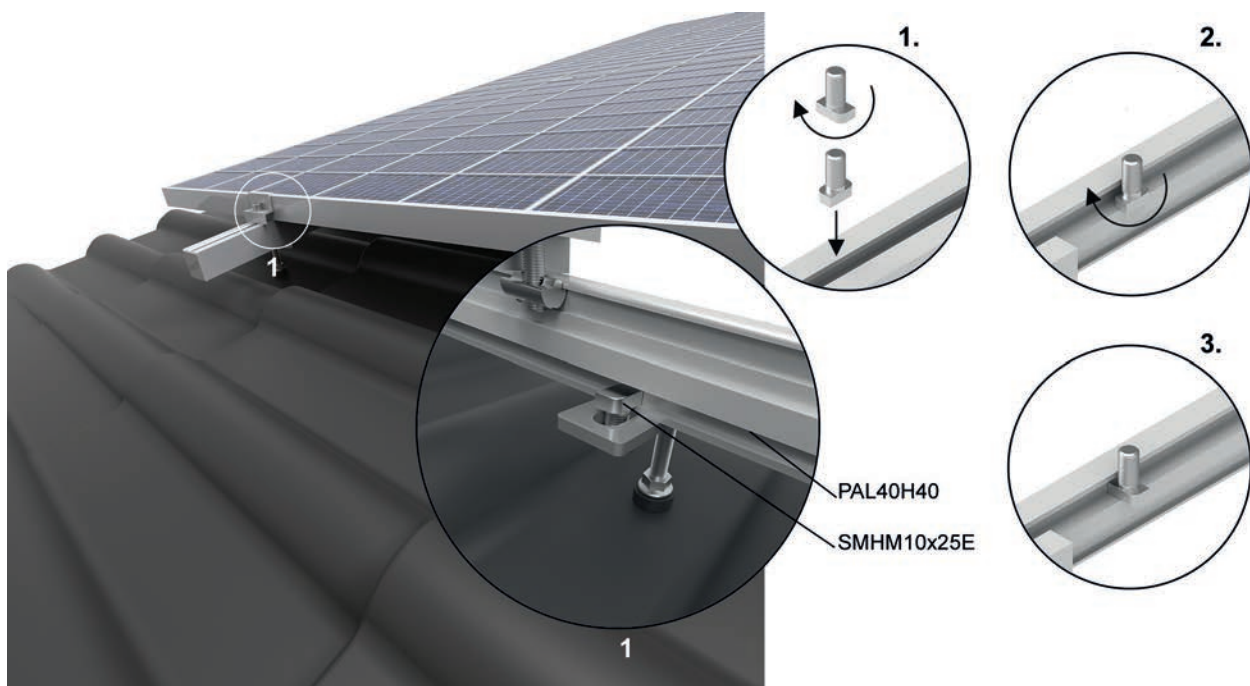

Screw	SRM...F	mat.: FP		
symbol	catalogue number	dimension L/M [mm]	quantity per package [pcs.]	STM
SRM8x25F	890102	25/8	100	
SRM8x30F	8901024	30/8	100	
SRM10x30F	6506513	30/10	100	

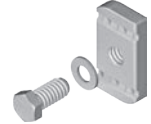
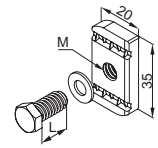

Use:
Fixing the system elements to the open side of the support channels or mounting channels.

Screw (set)	SMM...F	mat.: FP		
symbol	catalogue number	dimension L/M [mm]	quantity per package [pcs.]	STM
SMM8x60F	898660	60/8	100	
SMM8x80F	650548	80/8	100	
SMM10x20F	6508414	20/10	100	

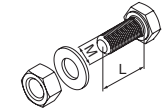

Use:
Connecting structure elements.

Screw Set	SGKF...	mat.: FP		
symbol	catalogue number	dimension M/L [mm]	flange D [mm]	quantity per package [pcs.]
SGKFM8x20	651820	8/20	20.5	100
SGKFM10x20PV	651643	10/20	20.5	100
SGKFM10x30	890111	10/30	20.5	100

STM

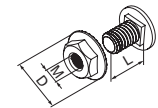

Additional information:
– 8.8 grade bolt

Screw set	SKK...E	mat.: E		
symbol	catalogue number	dimension M/L [mm]	flange D [mm]	quantity per package [pcs.]
SKKM8x12E	660352	8/12	17	100

STM

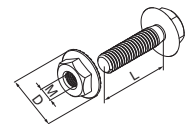

Use:
Connecting system components.

Additional information:
– 5.8 grade bolt
– size according to DIN 6921

Nut	NS...E	mat.: E		
symbol	catalogue number	dimension M [mm]	quantity per package [pcs.]	STM
NSM8E	652202	8	100	

Use:
Connecting structure elements.

Spring Washer	PS...E	mat.: E		
symbol	catalogue number	dimension D [mm]	quantity per package [pcs.]	STM
PS8E	166794	12.7	100	

Use:
Connecting structure elements.



Nut		NKZM...F	mat.: FP	
symbol	catalogue number	dimension M/D [mm]	quantity per package [pcs.]	STM
NKZM6F	6500453	6/15	100	
NKZM8F	6502453	8/17	100	

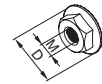

Nut		NKZM...E	mat.: E	
symbol	catalogue number	dimension M/D [mm]	quantity per package [pcs.]	STM
NKZM6E	6500451	6/15	100	
NKZM8E	890008	8/17	100	
NKZM10E	890009	10/19	100	

Use:
Connecting structure elements.

Rod Connector		NLM6E	mat.: E	
symbol	catalogue number	dimension M/D [mm]	quantity per package [pcs.]	STM
NLM6E	651103	6/18	100	

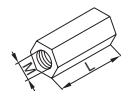

Use:
Connecting threaded rods of equal diameters.

Rod hanger		WPTMC	mat.: MC	option: E	
symbol	catalogue number	weight 1 pc. [kg]	quantity per package [pcs.]		N STM
Material thickness = 3.0 mm					
WPTMC	731305	0.11	50		

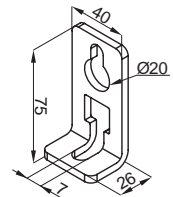

Use:
Fixing threaded rods as bracings for bifacial structures.

Additional information:
– special cut-outs allowing holder to be fitted on the threaded rod with pre-fitted nuts

1 - Assembly of bracings with WPTMC rod hanger

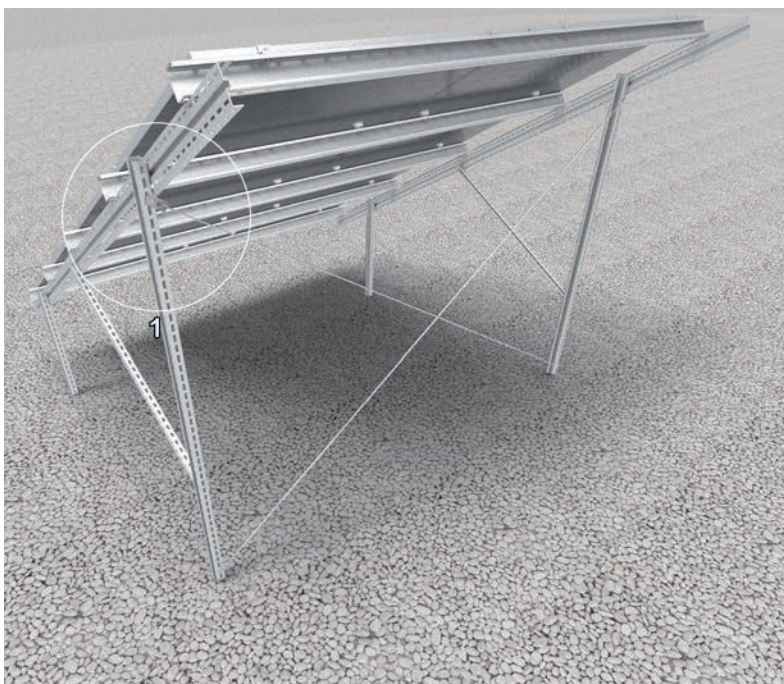

symbol	catalogue number	mat.: A	quantity per package [pcs.]
NKWSM8A	600909		200

STM

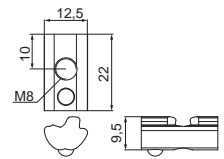

Use:
Mounting system components to aluminium profiles.

Additional information:
- optimum tightening torque = 12 - 15 Nm

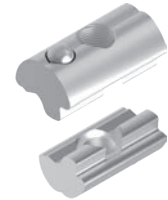

symbol	catalogue number	dimension L/Ø [mm]	quantity per package [pcs.]
SMDP6,0x25E	894824	25/6	200

STM

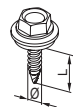

Use:
Mounting roof brackets and mounting rails for roofs covered with trapezoidal metal sheets.

Additional information:
- fine thread for increased pull-out strength



- 1 - Assembly of SMA70... Aluminum Mounting Rail to trapezoidal metal sheet with SMDP...
- 2 - Assembly of PV panels to aluminium profiles with BUF... Side Holders and NKWSM8A Slide Nut with a Ball

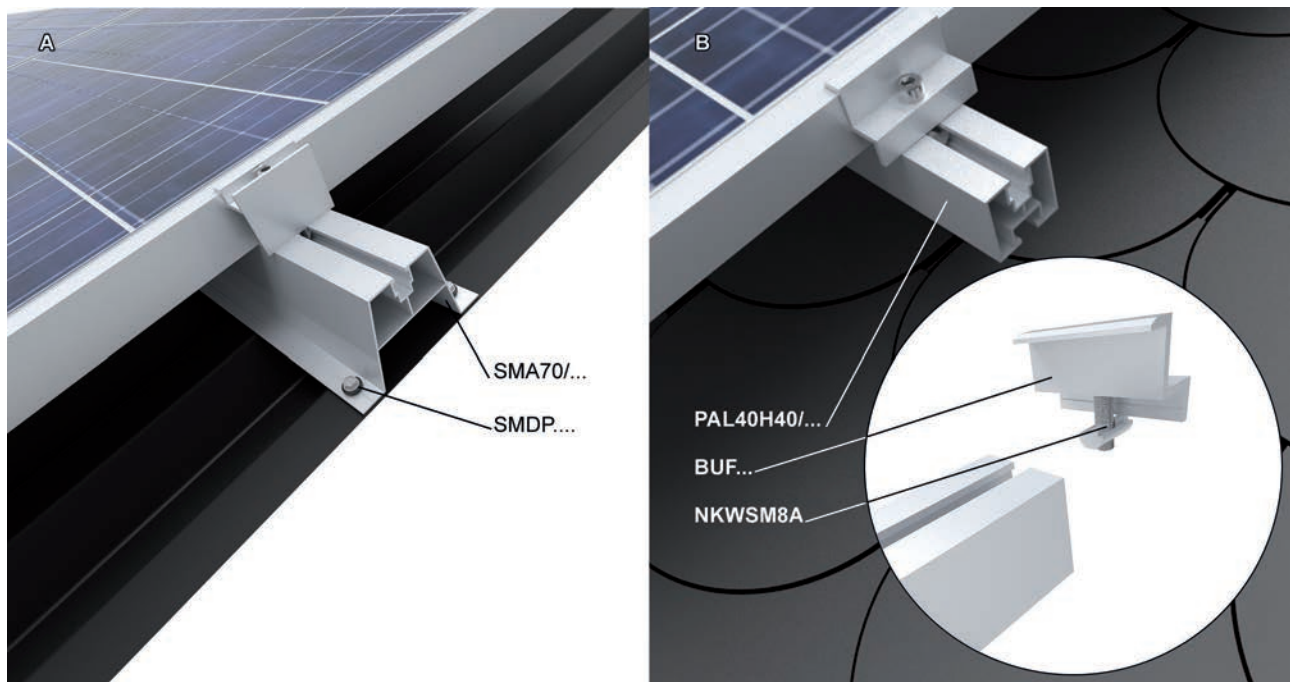

A - aluminium, E - stainless steel

Wood screw	DDW6x60E	mat.: E		STM
symbol	catalogue number	dimension L/D [mm]	quantity per package [pcs.]	
DDW6x60E	890661	60/6	100	

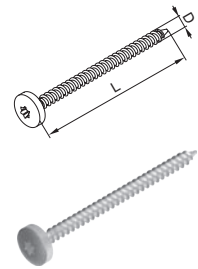

Wood screw	DDW8x100	mat.: G		STM
symbol	catalogue number	dimension L/D [mm]	quantity per package [pcs.]	
DDW8x100	890810	100/8	100	

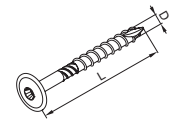

Wood screw	DDW8x100E	mat.: E		STM
symbol	catalogue number	dimension L/D [mm]	quantity per package [pcs.]	
DDW8x100E	8908101	100/8	100	



Use:
Mounting DUR40E and DUF75E brackets to the rafters that make up the roof structure.

- 1 - Assembly of DUR40E Adjustable Roof Fixing with DDW8x100 Wood Screws
- 2 - Assembly of DUF75E Roof Fixing with DDW8x100 Wood Screws

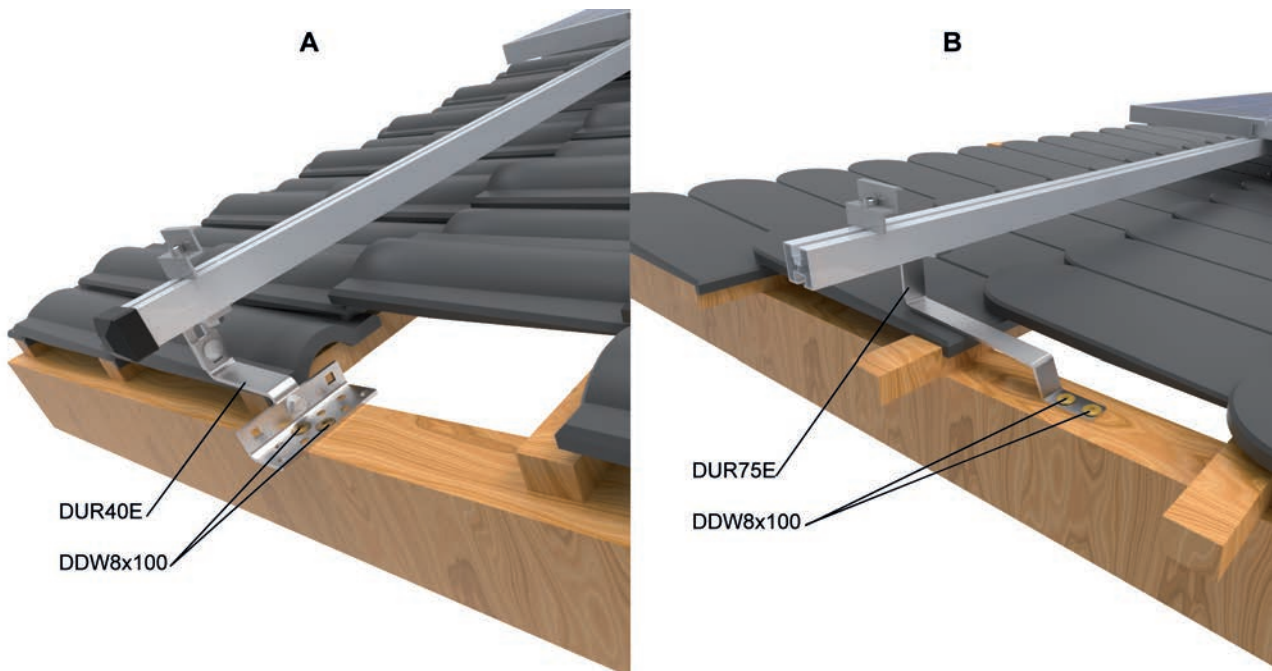

Screw- double thread		SWD...E	mat.: E		
symbol	catalogue number	dimension L/D/L ₁ [mm]	dimension L ₂ [mm]	quantity per package [pcs.]	STM
SWDM10x200E	898820	200/10/100	70	1	
SWDM10x250E	898825	250/10/140	80	1	
SWDM10x300E	898830	300/10/170	100	1	
SWDM12x300E	898831	300/12/170	100	1	

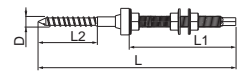

Use:
Mounting structure to roof rafters.

Mounting adapter		AD...	mat.: E		
symbol	catalogue number	dimension Ø [mm]	quantity per package [pcs.]		STM
Material thickness = 5.0 mm					
AD11E	898311	11	1		
AD13E	898312	13	1		

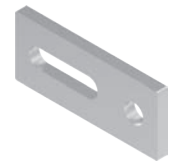
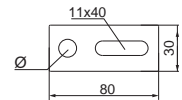

Use:
Connecting aluminium profiles with SWD...E double threaded screw.

Threaded rod		PGM6...E	mat.: E		
symbol	catalogue number	dimension L/M [mm]	breaking force [kN]	weight 1 pc. [kg]	quantity per package [pcs.]
PGM6/1E	652110	1000/6	8.44	0.12	25
PGM6/2E	652120	2000/6	8.44	0.23	25
PGM6/3E	650400	3000/6	8.44	0.35	25

STM

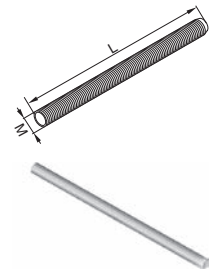

Use:
Mounting structures.

Additional information:
– material class 5.8

Anchor Bolt		PSR...F	mat.: FP		
symbol	catalogue number	dimension L/D [mm]	quantity per package [pcs.]		STM
PSRM8x75F	650875	75/8	100		
PSRM10x90F	650093	90/10	100		
PSRM12x110F	651211	110/12	100		

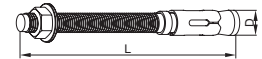

Use:
Mounting structures and suspending cable routes from the concrete substrate.

1 - Assembly of support structures on a sloping roof covered with metal sheet tiles with SWD...E and AD...E

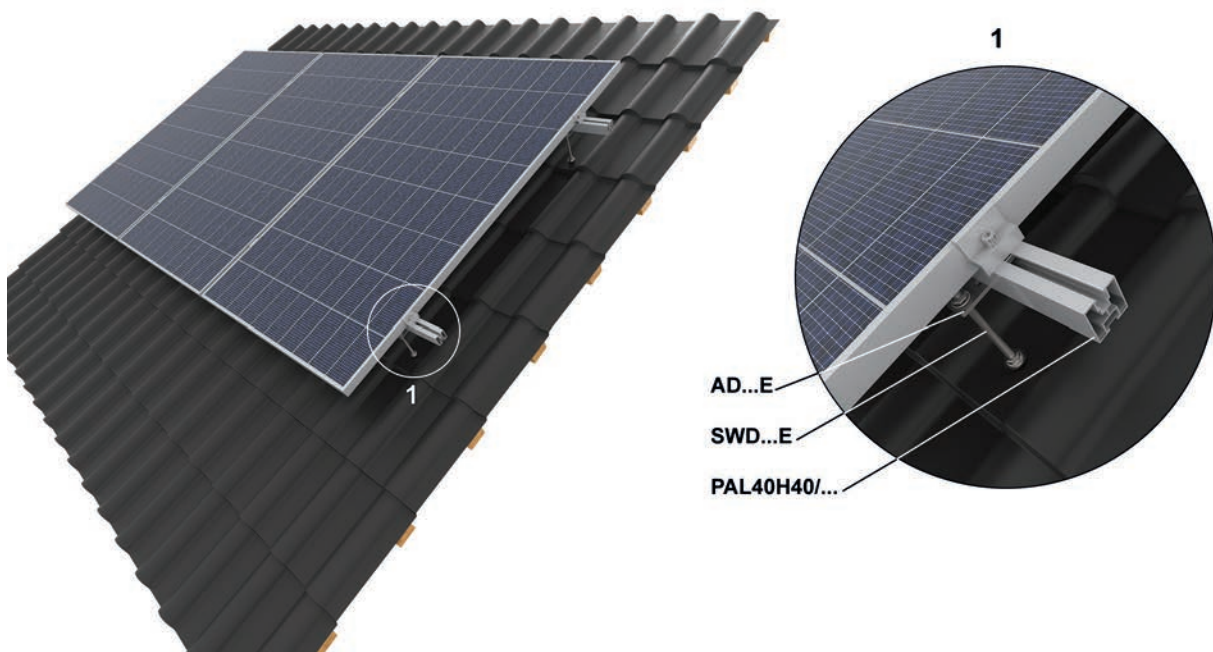

Accessories for electrical installation

Cable Tray CLICK **KFL...H60/3MC** mat.: MC

symbol	catalogue number	dimension a/L [mm]	weight 1 m [kg]	quantity per package [pcs./m]	min. order [m]
Material thickness = 0.7 mm					
KFL50H60/3MC	1610235	50/3000	0.98	4/12	12
KFL100H60/3MC	1612235	100/3000	1.17	4/12	12

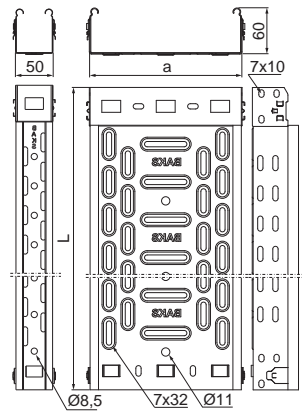

Use:

Routing a cable route.

Additional information:

- quick and easy mounting
- stable snap-in connection
- deep embossed holes in the bottom of the tray from the width 100 mm increased strength
- The dense perforation with ribbing provides excellent heat transfer and is designed to allow the tray to be mounted on a BAKS wall bracket anywhere
- Ø8.5 holes up to the width of 50 mm and Ø11 from the width of 100 mm in the bottom of the tray allow suspension on a single threaded rod (maximum width of the tray so suspended 200 mm)
- Magnelis-coating system can be supplemented with hot-dip zinc or stainless steel products
- **the CLICK system allows cable trays to be installed up to five times faster than traditional screw-mounted trays**

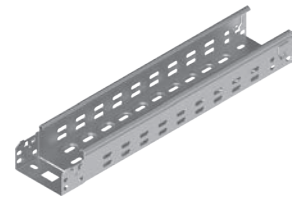

Cable Tray **KBL...H60/3MC** mat.: MC

symbol	catalogue number	dimension a/L [mm]	weight 1 m [kg]	quantity per package [pcs./m]	substitute
Material thickness = 0.7 mm					
KBL50H60/3MC	1618245	50/3000	1.10	4/12	KBJ50H60/3
KBL100H60/3MC	1620105	100/3000	1.10	4/12	KBJ50H60/3

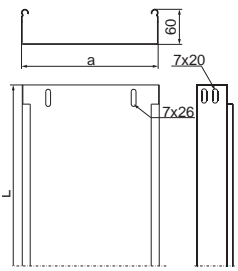

Use:

Routing a cable route.

Additional information:

- connector-less system – connecting trays by overlapping or inserting one into the other and bolting together with SGK6x12 or SGM6x12 bolts
- when using a replacement with a different height, all elements of the system must keep up with this parameter
- for large orders over 1000 m producing cable trays with the length of 6 m possible on request
- producing cable trays with the thickness of 1,0 mm possible on request



Electrical installation in a perforated KFL100H60/3MC cable tray

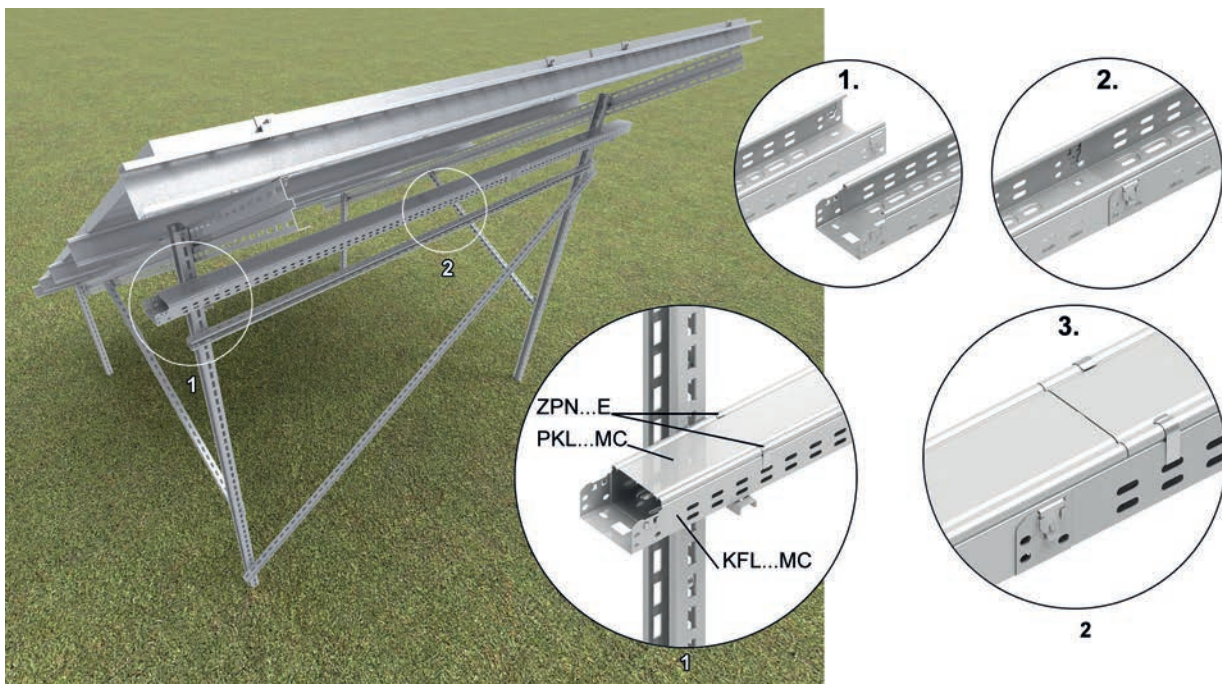



Connector LPU...H60MC mat.: MC

symbol	catalogue number	weight 1 pc. [kg]	quantity per package [pcs.]	min. order [pcs.]
Material thickness = 1.0 mm				
LPU1H60MC	1666215	0.03	100	2
Material thickness = 1.5 mm				
LPU2H60MC	1636115	0.04	100	2

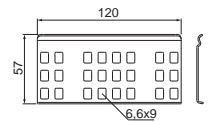

Use:

Connecting regular trays, lighting trays and cut-to-length KF... trays.

Additional information:

- mounting with 4 sets of SGKFM6x12
- thanks to dense perforation, the connector fits all BAKS trays of a given height
- Magnelis-coating system can be supplemented with hot-dip zinc or stainless steel products

Cable Tray Articulated Connector LG...H60MC mat.: MC

symbol	catalogue number	dimension H [mm]	weight 1 pc. [kg]	quantity per package [pcs.]	min. order [pcs.]
Material thickness = 1.0 mm					
LGJH60MC	1624005	48	0.08	100	2

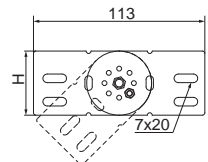

Use:

Connecting and changing the direction of route.

Additional information:

- mounting with 4 sets of SGKFM6x12
- Magnelis-coating system can be supplemented with hot-dip zinc or stainless steel products

Cable Tray Angle Connector LKJ...H60MC mat.: MC

symbol	catalogue number	dimension H/L [mm]	weight 1 pc. [kg]	quantity per package [pcs.]	min. order [pcs.]
Material thickness = 1.0 mm					
LKJH60MC	1625005	46/140	0.04	100	2

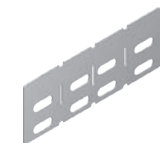
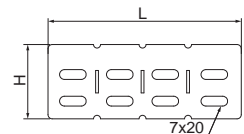

Use:

Connecting and changing the direction of route.

Additional information:

- possibility to break out and bend any section
- mounting with SGKFM6x12 bolts
- Magnelis-coating system can be supplemented with hot-dip zinc or stainless steel products

Accessories for electrical installation

Horizontal Bend 90° CLICK KKFJ...H60MC mat.: MC

symbol	catalogue number	dimension a [mm]	weight 1 pc. [kg]	quantity per package [pcs.]
Material thickness = 1.0 mm				
KKFJ50H60MC	1605615	50	0.22	1
KKFJ100H60MC	1611615	100	0.41	1

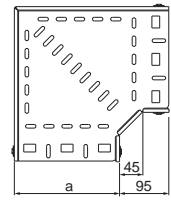

Use:
Changing the direction of CLICK type cable routing.

Additional information:

- screwless mounting
- Magnelis-coating system can be supplemented with hot-dip zinc or stainless steel products
- **the CLICK system allows cable trays to be installed up to five times faster than traditional screw-mounted trays**



Horizontal Bend 45° CLICK KKMfJ...H60MC mat.: MC

symbol	catalogue number	dimension a [mm]	weight 1 pc. [kg]	quantity per package [pcs.]
Material thickness = 1.0 mm				
KKMFJ50H60MC	1661675	50	0.18	1
KKMFJ100H60MC	1663675	100	0.27	1

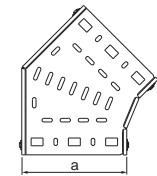

Use:
Changing the direction of CLICK type cable routing.



Horizontal Bend 90° KKBJ...H60MC mat.: MC

symbol	catalogue number	dimension a=b [mm]	weight 1 pc. [kg]	quantity per package
Material thickness = 1.0 mm				
KKBJ50H60MC	1629245	50	0.23	1
KKBJ100H60MC	1601015	100	0.42	1

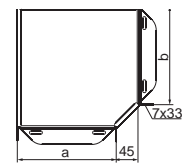

Use:
Changing the direction of CLICK type cable routing.

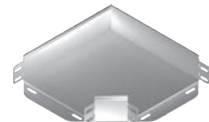

Electrical installation routed in a cable tray

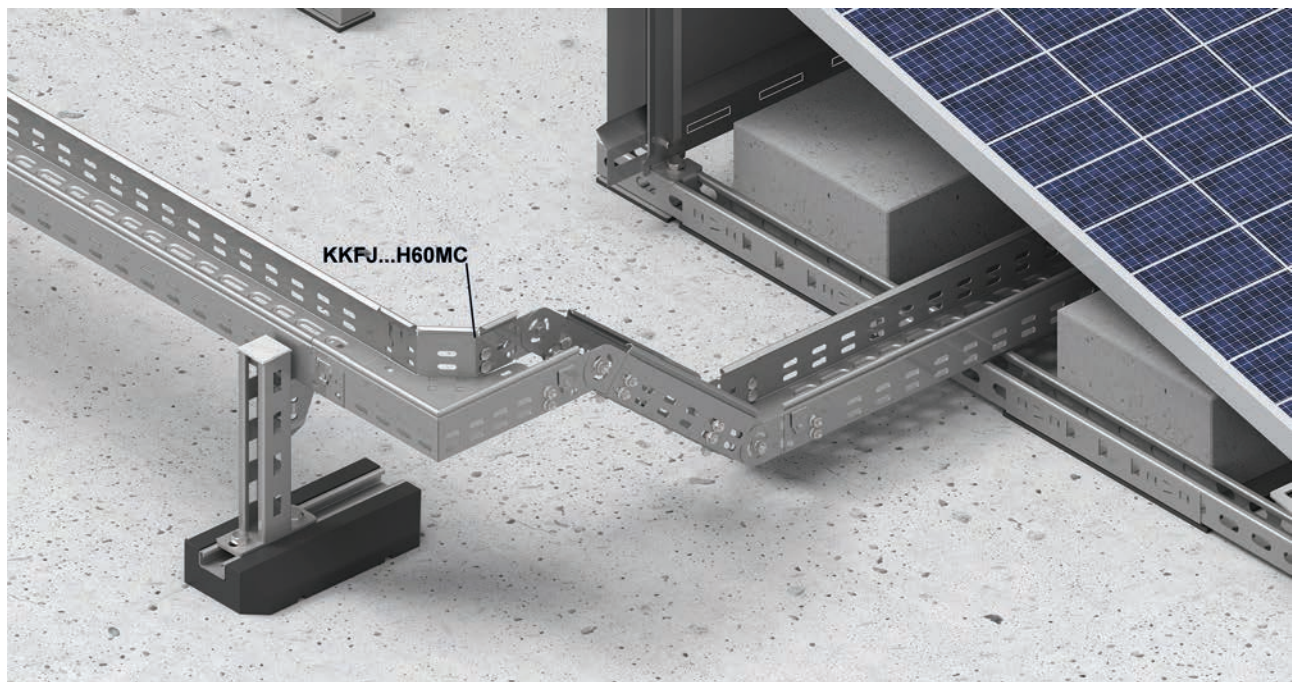

Accessories for electrical installation

Horizontal Bend 90° KKMBJ...H60MC mat.: MC

symbol	catalogue number	dimension a=b [mm]	weight 1 pc. [kg]	quantity per package [pcs.]
Material thickness = 1.0 mm				
KKMBJ50H60MC	1635245	50	0.16	1
KKMBJ100H60MC	1601035	100	0.30	1

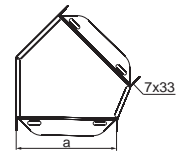

Use:

Changing the direction of the cable route.

Additional information:

- mounting with SGKM6x12 or SGM6x12 bolts for non-standard orders specify dimension a and b (if a=200 mm and b=100 mm – the ordered fitting should have the designation KK...200/100H60)

Adjustable Bend 90° KKRPJ...H60MC mat.: MC

symbol	catalogue number	dimension a [mm]	weight 1 pc. [kg]	quantity per package [pcs.]
Material thickness = 1.0 mm				
KKRPJ50H60MC	1409195	54	0.16	1
KKRPJ100H60MC	1409215	104	0.30	1

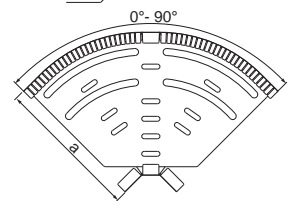
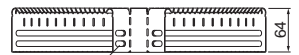

Use:

Changing the direction of the cable route.

Additional information:

- mounting with bolts SGKM6x12 or SGM6x12
- mounting trays inside fittings
- angle adjustment from 0-90°

CLICK Tee TKFJ...H60MC mat.: MC

symbol	catalogue number	dimension a [mm]	weight 1 pc. [kg]	quantity per package [pcs.]
Material thickness = 1.0 mm				
TKFJ50H60MC	1662615	50	0.28	1
TKFJ100H60MC	1662625	100	0.45	1
TKFJ400H60MC	1662665	400	2.26	1

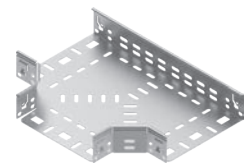
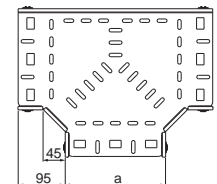

Use:

CLICK type cable route branching.

Additional information:

- screwless mounting
- Magnelis-coating system can be supplemented with hot-dip zinc or stainless steel products
- **the CLICK system allows cable trays to be installed up to five times faster than traditional screw-mounted trays**

Horizontal Tee TKBJ...H60MC mat.: MC

symbol	catalogue number	dimension a=b=c [mm]	weight 1 pc. [kg]	quantity per package [pcs.]	substitute
TKBJ50H60MC	1641245	50	0.29	1	TKJ50H60
TKBJ100H60MC	1609015	100	0.46	1	TKJ50H60

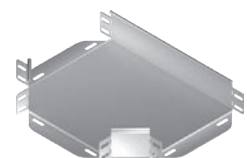
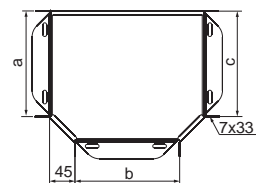

Use:

Cable route branching.

Additional information:

- mounting with bolts SGKM6x12 or SGM6x12
- for non-standard orders specify dimension a, b and c (if a=100 mm, b=300 mm and c=200 mm the ordered fitting should have the designation TK...100/300/200H...)

Accessories for electrical installation

Add-on Tee CLICK **TKDFJ...H60MC** mat.: MC

symbol	catalogue number	dimension a [mm]	weight 1 pc. [kg]	quantity per package [pcs.]
Material thickness = 1.0 mm				
TKDFJ50H60MC	1648265	50	0.32	1
TKDFJ100H60MC	1635265	100	0.44	1

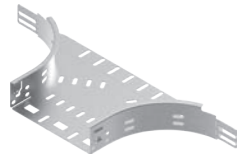
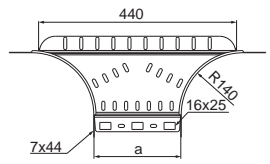

Use:
CLICK type cable route branching.

- Additional information:**
- mounting to the side of the tray with SGK6x12 or SGM6x12 bolts
 - Magnelis-coating system can be supplemented with hot-dip zinc or stainless steel products

Add-on Tee **TKD...H60MC** mat.: MC

symbol	catalogue number	dimension a [mm]	weight 1 pc. [kg]	quantity per package [pcs.]
Material thickness = 1.0 mm				
TKDJ50H60MC	1697055	50	0.32	20
TKDJ100H60MC	1697105	100	0.44	10

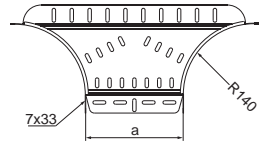

- Additional information:**
- mounting with SGKFM6x12 bolts
 - Magnelis-coating system can be supplemented with hot-dip zinc or stainless steel products

Electrical installation routed in a cable tray

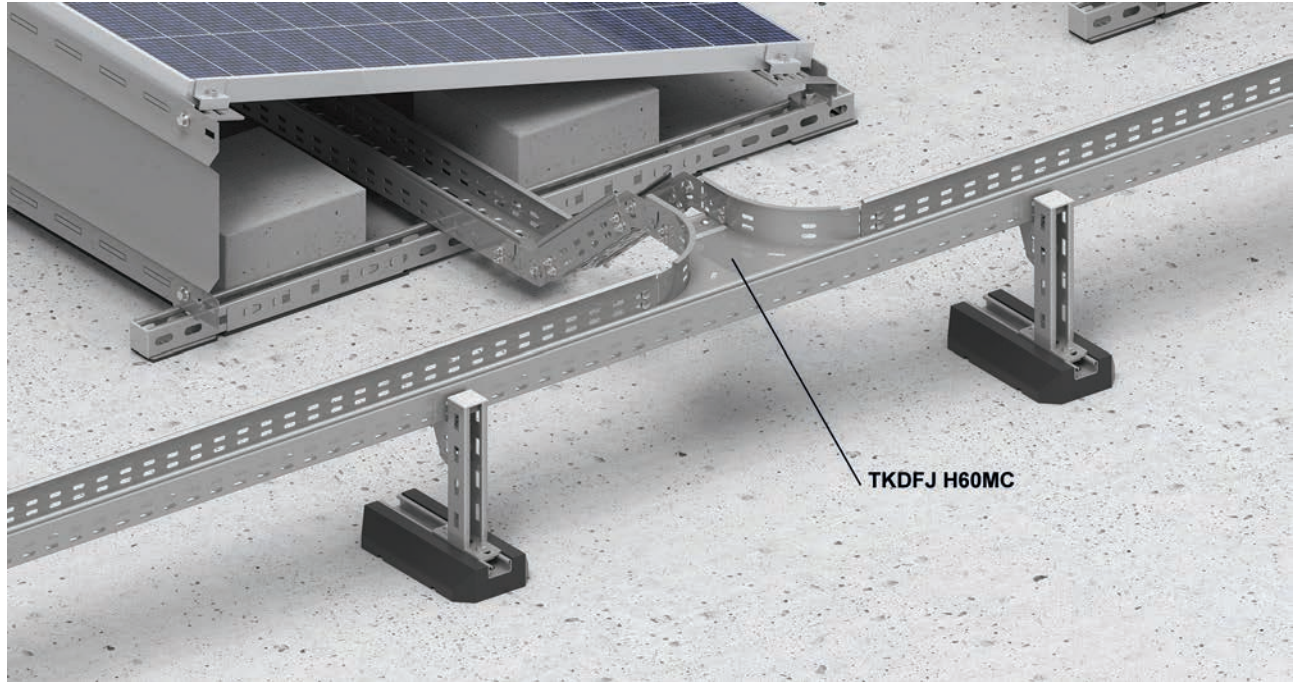

Accessories for electrical installation

Reduction tee TRJ...H60MC mat.: MC

symbol	catalogue number	dimension a [mm]	weight 1 pc. [kg]	quantity per package [pcs.]
Material thickness = 1.0 mm				
TRJ50H60MC	1633235	50	0.62	1
TRJ100H60MC	1686105	100	0.95	1

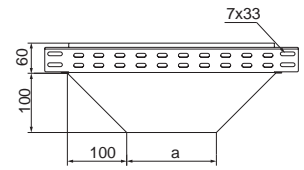

Use:

Cable route branching.

Additional information:

- mounting with bolts SGK6x12 or SGM6x12

CLICK Cross-over CZKFJ...H60MC mat.: MC

symbol	catalogue number	dimension a [mm]	weight 1 pc. [kg]	quantity per package [pcs.]	substitute
Material thickness = 1.0 mm					
CZKFJ50H60MC	1661685	50	0.39	1	CZPFJ50H60
CZKFJ100H60MC	1663685	100	0.57	1	CZPFJ50H60

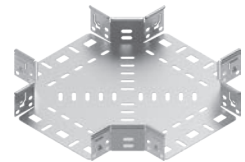
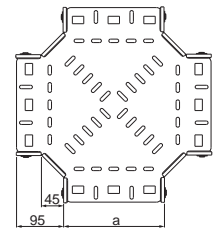

Use:

CLICK type cable route branching.

Additional information:

- screwless mounting
- the CLICK system allows cable trays to be installed up to five times faster than traditional screw-mounted trays

Horizontal Cross-over CZKBJ...H60MC mat.: MC

symbol	catalogue number	dimension a [mm]	weight 1 pc. [kg]	quantity per package [pcs.]
Material thickness = 1.0 mm				
CZKBJ50H60MC	1647245	50	0.32	1
CZKBJ100H60MC	1609035	100	0.47	1

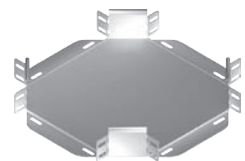
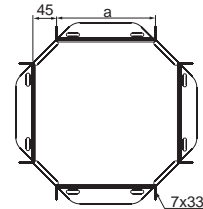

Use:

Cable route branching.

Additional information:

- mounting with bolts SGK6x12 or SGM6x12

CLICK Left Reducer RKLfJ...H60MC mat.: MC

symbol	catalogue number	dimension a/b [mm]	weight 1 pc. [kg]	quantity per package [pcs.]
Material thickness = 1.0 mm				
RKLfJ100/50H60MC	1646125	100/50	0.30	1

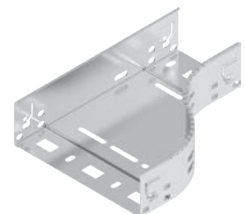
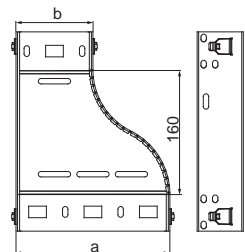

Use:

CLICK type cable route branching.

Additional information:

- screwless mounting
- the CLICK system allows cable trays to be installed up to five times faster than traditional screw-mounted trays

Accessories for electrical installation

CLICK Right Reducer RKPJ...H60MC mat.: MC

symbol	catalogue number	dimension a/b [mm]	weight 1 pc. [kg]	quantity per package [pcs.]
Material thickness = 1.0 mm				
RKPFJ100/50H60MC	1651125	100/50	0.30	1

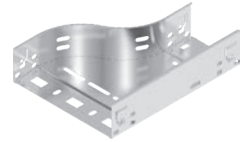
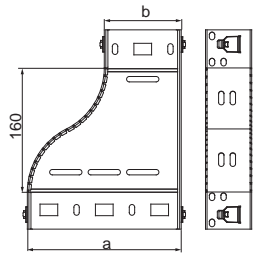

Use:

Changing the width of the cable route CLICK.

Additional information:

- screwless mounting
- the CLICK system allows cable trays to be installed up to five times faster than traditional screw-mounted trays

CLICK Straight Reducer RKSFJ...H60MC mat.: MC

symbol	catalogue number	dimension a/b [mm]	weight 1 pc. [kg]	quantity per package [pcs.]
Material thickness = 1.0 mm				
RKSFJ100/50H60MC	1656125	100/50	0.30	1

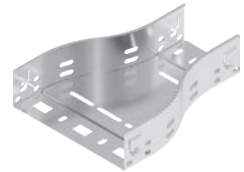
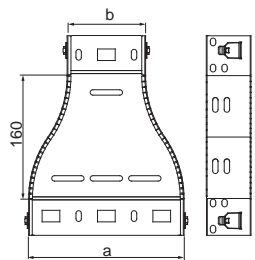

Use:

Changing the width of the cable route CLICK.

Additional information:

- screwless mounting
- the CLICK system allows cable trays to be installed up to five times faster than traditional screw-mounted trays

Left Reducer RKLBJ...H60MC mat.: MC

symbol	catalogue number	dimension a/b [mm]	weight 1 pc. [kg]	quantity per package [pcs.]	substitute
Material thickness = 1.0 mm					
RKLBJ100/50H60MC	1657245	100/50	0.24	1	RKLJ100/50H60

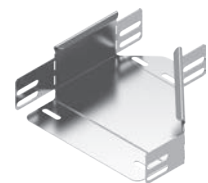
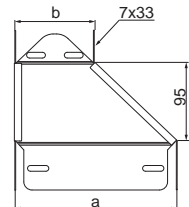

Use:

Changing the width of the cable route.

Additional information:

- mounting with SGK6x12 or SGM6x12 bolts for nonstandard orders specify dimension a and b (if a=400 mm and b=200 mm – the ordered fitting should have the designation RK...400/200H60)

Right Reducer RKPBJ...H60MC mat.: MC

symbol	catalogue number	dimension a/b [mm]	weight 1 pc. [kg]	quantity per package [pcs.]	substitute
Material thickness = 1.0 mm					
RKPBJ100/50H60MC	1659245	100/50	0.24	1	RKPJ100/50H60

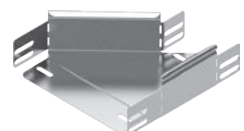
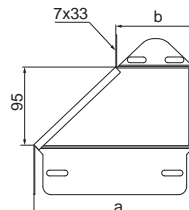

Use:

Changing the width of the cable route.

Additional information:

- mounting with SGK6x12 or SGM6x12 bolts for nonstandard orders specify dimension a and b (if a=400 mm and b=200 mm – the ordered fitting should have the designation RK...400/200H60)

Accessories for electrical installation

Straight Reducer

RKSBJ...H60MC mat.: MC

symbol catalogue number dimension a/b [mm] weight 1 pc. [kg] quantity per package [pcs.] substitute

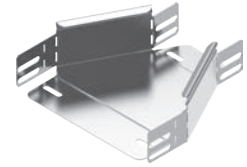
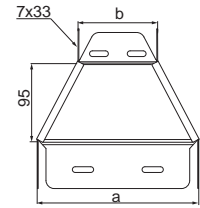

Material thickness = 1.0 mm

RKSBJ100/50H60MC	1661245	100/50	0.24	1	RKSJ100/50H60
------------------	---------	--------	------	---	---------------

Use:

Changing the width of the cable route.

Additional information:

- mounting with SGK6x12 or SGM6x12 bolts for nonstandard orders specify dimension a and b (if a=400 mm and b=200 mm – the ordered fitting should have the designation RK...400/200H60)

Joint Protection Plate

BL...MC mat.: MC

symbol catalogue number dimension L [mm] weight 1 pc. [kg] quantity per package [pcs.] substitute

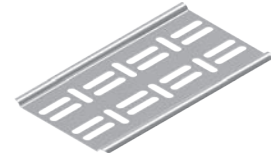
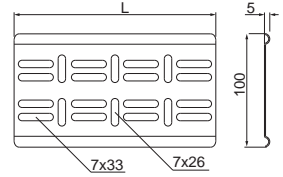

Material thickness = 1.0 mm

BL50MC	810105	46	0.03	100	
BL100MC	1001105	92	0.06	100	

Use:

Protection of cables from damage at the junction of two trays (especially in the case of cut trays). Additional reinforcement of the tray connection.

Additional information:

- recommended use when connecting trays using angle connectors
- mounting with SGK6x12 bolts for width: - 100-200 mm - 4 sets - 300-400 mm - 6 sets - 500-600 mm - 10 sets

Edge Protection Plate

BZK...MC mat.: MC

symbol catalogue number dimension L [mm] weight 1 pc. [kg] quantity per package [pcs.] substitute

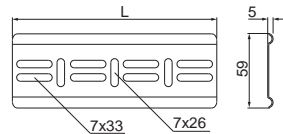

Material thickness = 1.0 mm

BZK50MC	810215	46	0.02	100	
BZK100MC	1002105	96	0.04	100	

Use:

Protection of cables from damage at the end of the tray.

Additional information:

- mounting with SGK6x12 bolts for width: - 100-200 mm - 2 sets - 300-400 mm - 3 sets - 500-600 mm - 5 sets

Electrical installation routed in a cable tray

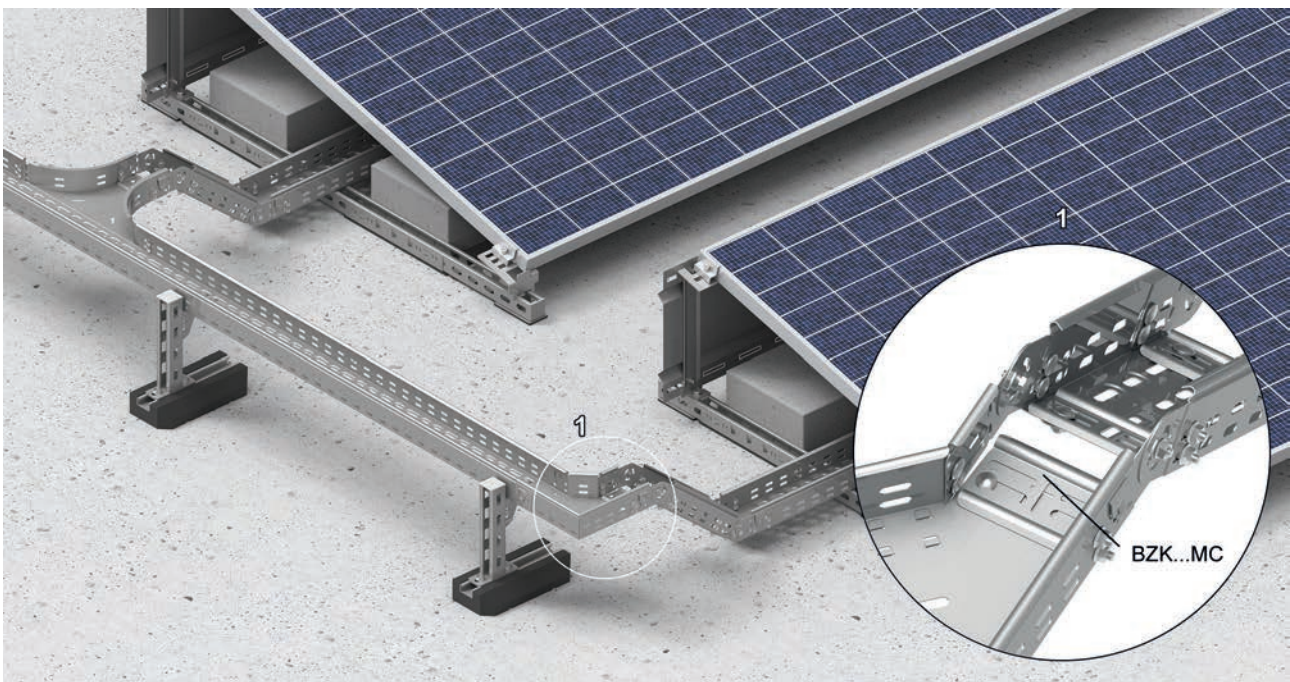

Accessories for electrical installation

Cover	PKL...MC	mat.: MC			
symbol	catalogue number	dimension a/L [mm]	weight 1 m [kg]	quantity per package [pcs./m]	min. order [m]
Material thickness = 0.7 mm					
PKL50/3MC	1006055	50/3000	0.42	20/60	3
PKL100/3MC	1006105	100/3000	0.72	10/30	3

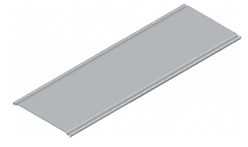
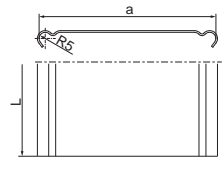

Use:
Protection of cables from dust accumulation and mechanical damage and weathering (e.g. UV radiation).

Additional information:

- recommended to use additional clips
- Magnelis-coating system can be supplemented with hot-dip zinc or stainless steel products

Cover Clamp	ZPNNH60E2	mat.: E2	
symbol	catalogue number	dimension H [mm]	quantity per package [pcs.]
ZPNNH60E2	140006	34	100

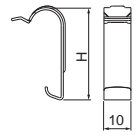

Use:
Screwless cover mounting.

Additional information:

- mounting covers for perforated and mesh trays
- stainless steel clips are more durable and visually pleasing
- modified hooks work better with the cover
- products made of stainless steel grade 1.4301 (304)

A - Electrical installation in an unperforated KBL100H60/3MC cable tray
B - Assembly of TOZ... Edge Protection Strip

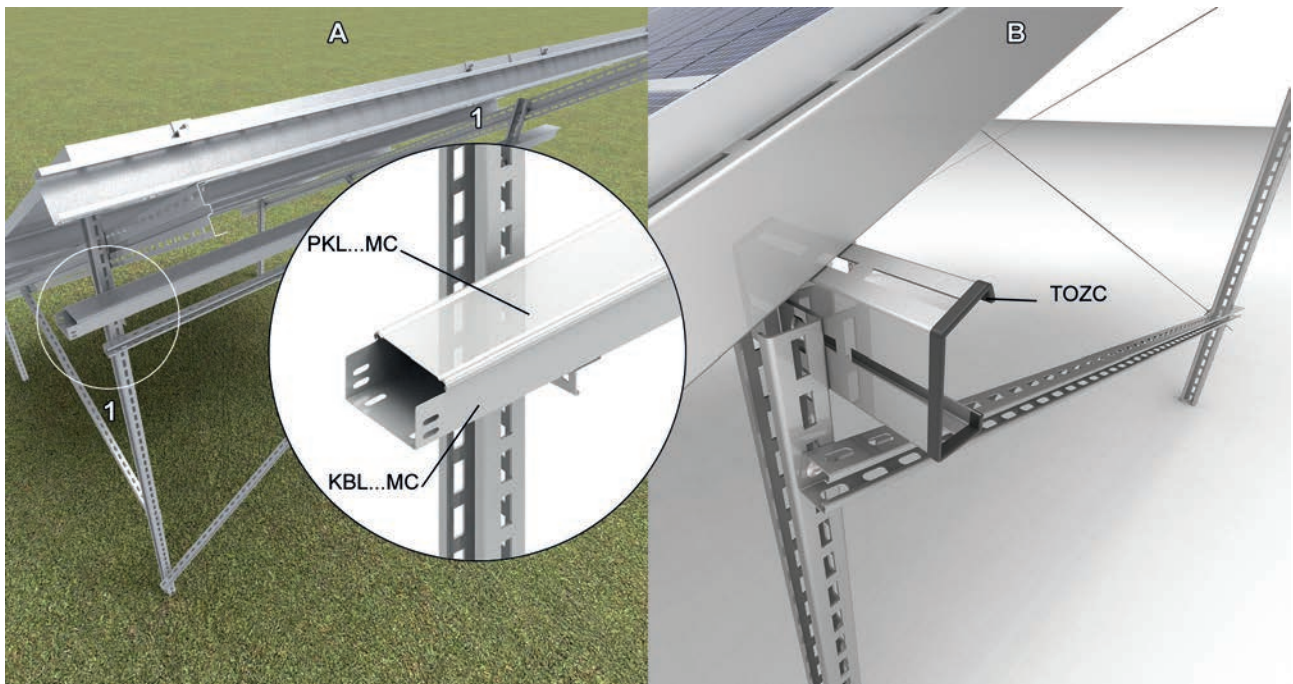

Accessories for electrical installation

Edge Protection Strip	TOZ...	mat.: PVC		
symbol	catalogue number	colour	quantity per package [m]	min. order [m]
TOZ	100800	white	10	10
TOZS	100880	silver	10	10
TOZC	100881	black	10	10

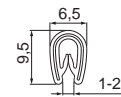

Use:
Protection of sharp edges in the components of cable routes that can damage wires/cables.

Additional information:

- reinforced tape
- recommended working temperature from -25° to 60°C
- weather resistance
- resistant to ageing
- ozone-resistant
- UV resistance
- resistant to chemicals
- hot water and steam resistance
- 1-2 mm sheet thickness range

Edge Protection Strip	TOZ14...	mat.: PVC		
symbol	catalogue number	colour	quantity per package [m]	min. order [m]
TOZ14	100882	white	10	10
TOZ14S	100883	silver	10	10
TOZ14C	100884	black	10	10

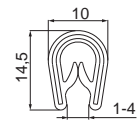

Use:
Protection of sharp edges in the components of cable routes that can damage wires/cables.

Additional information:

- reinforced tape
- recommended working temperature from -25° to 60°C
- weather resistance
- resistant to ageing
- ozone-resistant
- UV resistance
- resistant to chemicals
- hot water and steam resistance
- 1-4 mm sheet thickness range

A - Electrical installation in an unperforated KBL100H60/3MC cable tray
B - Assembly of TOZ... Edge Protection Strip

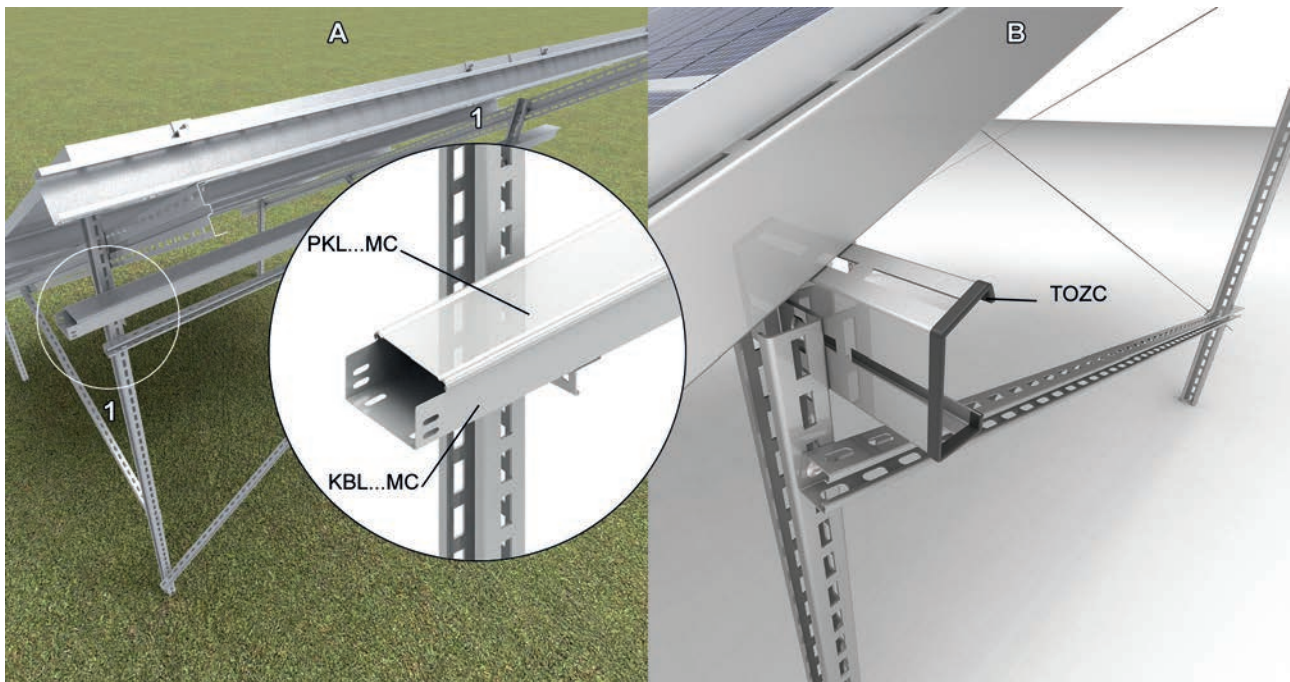

Accessories for electrical installation

Cover For 90° Horizontal Bend **PKKFJ...MC** mat.: MC

symbol	catalogue number	dimension a [mm]	weight 1 pc. [kg]	quantity per package [pcs.]
Material thickness = 1.0 mm				
PKKFJ50MC	1656525	50	0.13	1
PKKFJ100MC	1655535	100	0.27	1

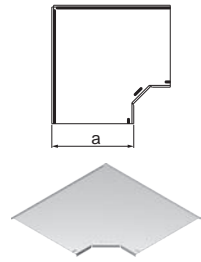
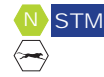

Use:

Protection of cables from dust accumulation and mechanical damage and weathering (e.g. UV radiation).

Additional information:

- cover fits KKFJ...H60 elbows
- recommended to use additional clips
- Magnelis-coating system can be supplemented with hot-dip zinc or stainless steel products

Cover For 90° Horizontal Bend **PKKJ...MC** mat.: MC

symbol	catalogue number	dimension a [mm]	weight 1 pc. [kg]	quantity per package [pcs.]
Material thickness = 1.0 mm				
PKKJ50MC	1024055	50	0.08	1
PKKJ100MC	1024105	100	0.16	1

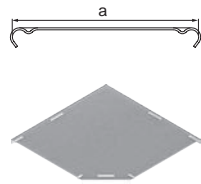
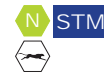

Use:

Protection of cables from dust accumulation and mechanical damage and weathering (e.g. UV radiation).

Additional information:

- recommended to use additional clips

Cover For 45° Horizontal Bend **PKKMFJ...MC** mat.: MC

symbol	catalogue number	dimension a [mm]	weight 1 pc. [kg]	quantity per package [pcs.]
Material thickness = 1.0 mm				
PKKMFJ50MC	1500055	50	0.09	1
PKKMFJ100MC	1500105	100	0.18	1

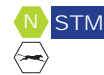

Use:

Protection of cables from dust accumulation and mechanical damage and weathering (e.g. UV radiation).

Additional information:

- cover fits KKMfJ...H60 elbows
- recommended to use additional clips
- Magnelis-coating system can be supplemented with hot-dip zinc or stainless steel products

Electrical installation routed in a cable tray

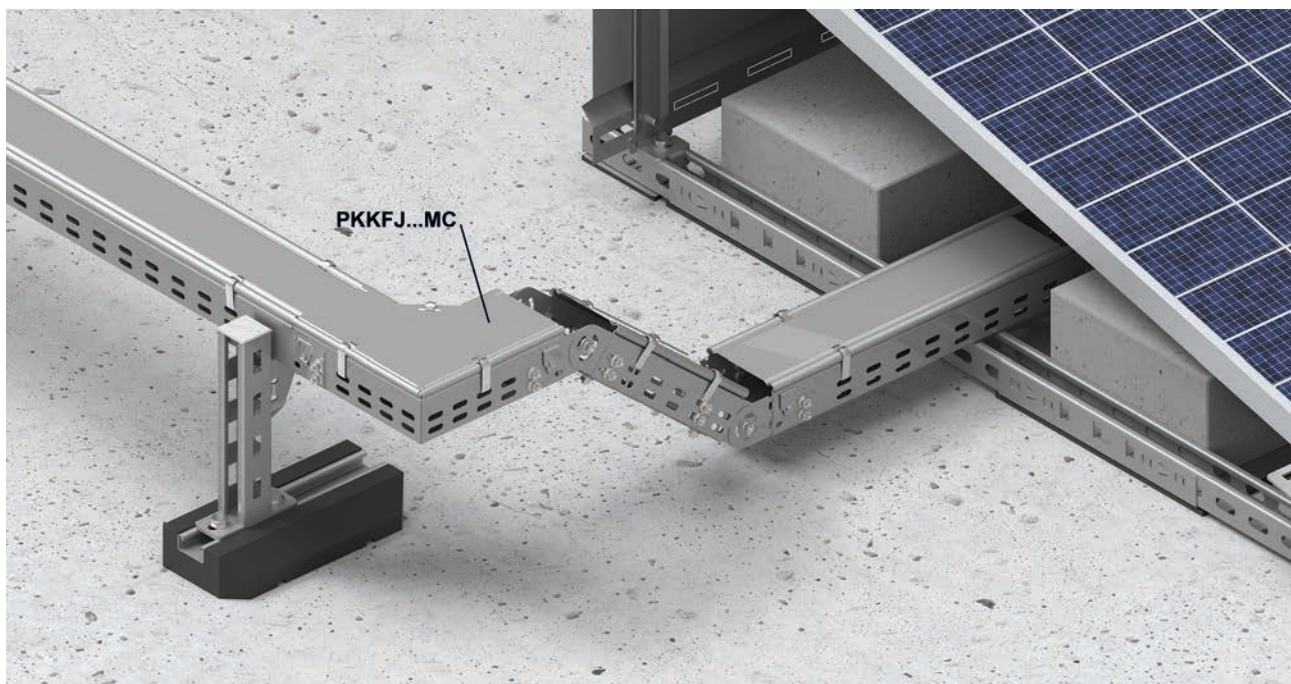

Accessories for electrical installation

Cover For 45° Horizontal Bend PPKMJ...MC mat.: MC

symbol	catalogue number	dimension a [mm]	weight 1 pc. [kg]	quantity per package [pcs.]
Material thickness = 1.0 mm				
PPKMJ50MC	1027055	50	0.06	1
PPKMJ100MC	1027105	100	0.11	1

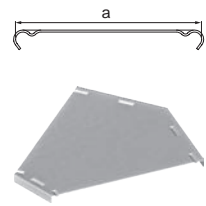
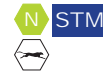

Use:
Protection of cables from dust accumulation and mechanical damage and weathering (e.g. UV radiation).

Additional information:

- recommended to use additional clips

Cover For Horizontal Tee CLICK PTKFJ...MC mat.: MC

symbol	catalogue number	dimension a [mm]	weight 1 pc. [kg]	quantity per package [pcs.]
Material thickness = 1.0 mm				
PTKFJ50MC	1656615	50	0.18	1
PTKFJ100MC	1656625	100	0.36	1

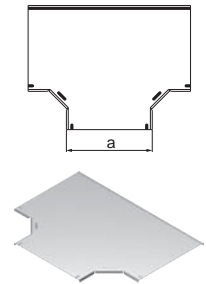

Use:
Protection of cables from dust accumulation and mechanical damage and weathering (e.g. UV radiation).

Additional information:

- cover fits TKFJ...H60 tees
- recommended to use additional clips
- Magnelis-coating system can be supplemented with hot-dip zinc or stainless steel products

Cover For Horizontal Tee PTKJ...MC mat.: MC

symbol	catalogue number	dimension a [mm]	weight 1 pc. [kg]	quantity per package [pcs.]
Material thickness = 1.0 mm				
PTKJ50MC	1030055	50	0.10	1
PTKJ100MC	1030105	100	0.20	1

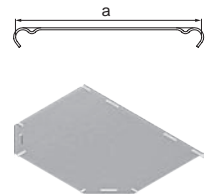
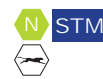

Use:
Protection of cables from dust accumulation and mechanical damage and weathering (e.g. UV radiation).

Additional information:

- recommended to use additional clips

Electrical installation routed in a cable tray

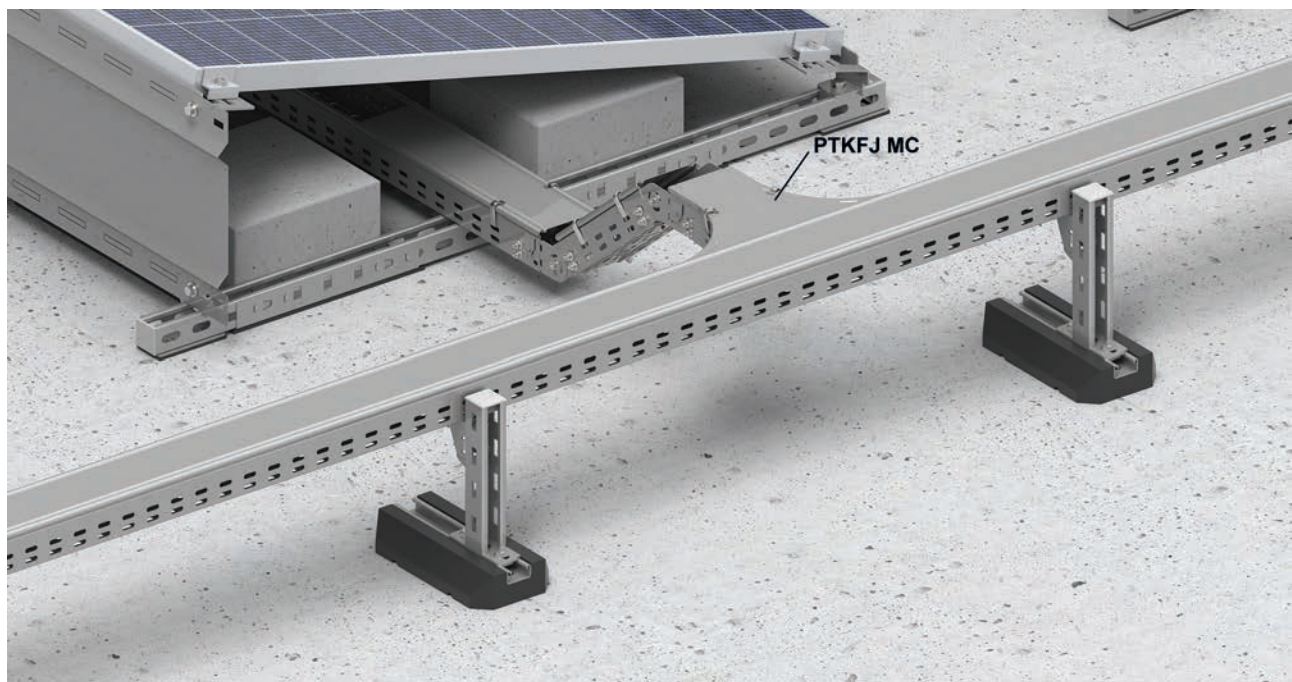

Accessories for electrical installation

Cover For Add-on Tee CLICK PTKDFJ...MC mat.: MC

symbol	catalogue number	dimension a [mm]	weight 1 pc. [kg]	quantity per package [pcs.]
Material thickness = 1.0 mm				
PTKDFJ50MC	1500215	50	0.10	1
PTKDFJ100MC	1500235	100	0.20	1

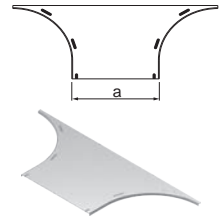
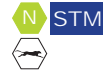

Use:
Protection of cables from dust accumulation and mechanical damage and weathering (e.g. UV radiation).

Additional information:

- cover fits TKDFJ...H60 reducer tees
- recommended to use additional clips
- Magnelis-coating system can be supplemented with hot-dip zinc or stainless steel products

Cover For Add-on Tee PTKDJ...MC mat.: MC

symbol	catalogue number	dimension a [mm]	weight 1 pc. [kg]	quantity per package [pcs.]
Material thickness = 1.0 mm				
PTKDJ50MC	1049135	50	0.10	1
PTKDJ100MC	1050135	100	0.20	1

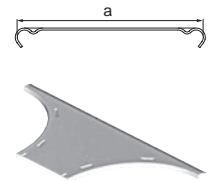
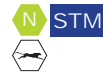

Use:
Protection of cables from dust accumulation and mechanical damage and weathering (e.g. UV radiation).

Cover for Reduction Tee PTRRZP...MC mat.: MC

symbol	catalogue number	dimension a [mm]	weight 1 pc. [kg]	quantity per package [pcs.]
Material thickness = 1.5 mm				
PTRRZP50MC	3068055	50	0.29	1
PTRRZP100MC	3068105	100	0.60	1

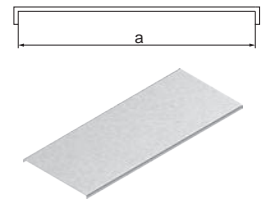

Use:
Protects cables from damage, UV rays and weather conditions. Airtight protection against the accumulation of dust and dirt.

Additional information:

- recommended to use additional clips

Cover For CLICK Horizontal Cross-over PCZKFJ...MC mat.: MC

symbol	catalogue number	dimension a [mm]	weight 1 pc. [kg]	quantity per package [pcs.]
Material thickness = 1.0 mm				
PCZKFJ50MC	1500315	50	0.23	1
PCZKFJ100MC	1500325	100	0.44	1

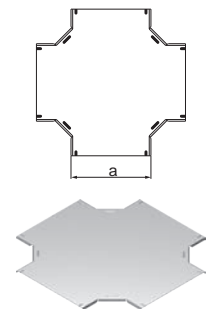
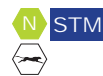

Use:
Protects cables from damage, UV rays and weather conditions. Airtight protection against the accumulation of dust and dirt.

Additional information:

- cover fits CZKFJ...H60 cross-overs
- recommended to use additional clips

Cover For Cross-over PCZKJ...MC mat.: MC

symbol	catalogue number	dimension a [mm]	weight 1 pc. [kg]	quantity per package [pcs.]
Material thickness = 1.0 mm				
PCZKJ50MC	1033055	50	0.32	1
PCZKJ100MC	1033105	100	0.47	1

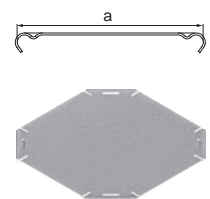

Use:
Protects cables from damage, UV rays and weather conditions. Airtight protection against the accumulation of dust and dirt.

Accessories for electrical installation

Cover For Reducer CLICK left PRKLFJ100/50MC mat.: MC

symbol	catalogue number	dimension a/b [mm]	weight 1 pc. [kg]	quantity per package [pcs.]
Material thickness = 1.0 mm				
PRKLFJ100/50MC	1681125	100/50	0.12	1

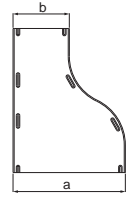
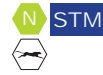

Use:

Protects cables from damage, UV rays and weather conditions. Airtight protection against the accumulation of dust and dirt.

Additional information:

- recommended to use additional clips

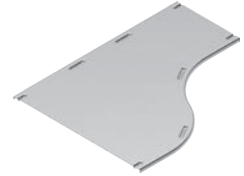

Cover for CLICK right reducer PRKPFJ100/50MC mat.: MC

symbol	catalogue number	dimension a/b [mm]	weight 1 pc. [kg]	quantity per package [pcs.]
Material thickness = 1.0 mm				
PRKPFJ100/50MC	1686125	100/50	0.12	1

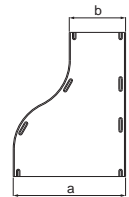
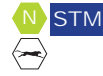

Use:

Protects cables from damage, UV rays and weather conditions. Airtight protection against the accumulation of dust and dirt.

Additional information:

- recommended to use additional clips

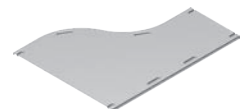

Cover for CLICK straight reducer PRKSFJ100/50MC mat.: MC

symbol	catalogue number	dimension a/b [mm]	weight 1 pc. [kg]	quantity per package [pcs.]
Material thickness = 1.0 mm				
PRKSFJ100/50MC	1691125	100/50	0.12	1

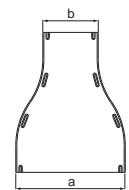
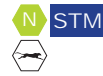

Use:

Protects cables from damage, UV rays and weather conditions. Airtight protection against the accumulation of dust and dirt.

Additional information:

- recommended to use additional clips

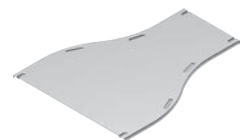

Accessories for electrical installation

Cover for Left Reducer PRKLJ100/50MC mat.: MC

symbol	catalogue number	dimension a/b [mm]	weight 1 pc. [kg]	quantity per package [pcs.]
Material thickness = 1.0 mm				
PRKLJ100/50MC	1048105	100/50	0.10	1

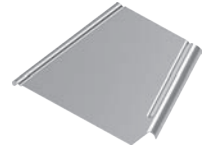
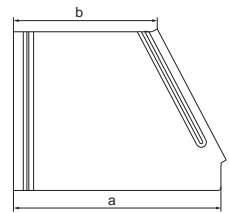
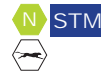

Use:

Protection of cables from dust accumulation and mechanical damage and weathering (e.g. UV radiation).

Additional information:

- recommended to use additional clips

Cover For Right Reducer PRKPJ100/50MC mat.: MC

symbol	catalogue number	dimension a/b [mm]	weight 1 pc. [kg]	quantity per package [pcs.]
Material thickness = 1.0 mm				
PRKPJ100/50MC	1051105	100/50	0.10	1

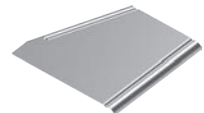
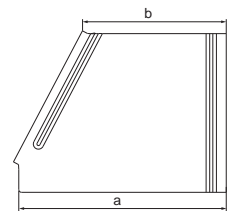
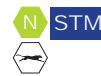

Use:

Protection of cables from dust accumulation and mechanical damage and weathering (e.g. UV radiation).

Additional information:

- recommended to use additional clips

Cover For Straight Reducer PRKSJ100/50MC mat.: MC

symbol	catalogue number	dimension a/b [mm]	weight 1 pc. [kg]	quantity per package [pcs.]
Material thickness = 1.0 mm				
PRKSJ100/50MC	1045105	100/50	0.10	1

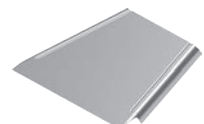
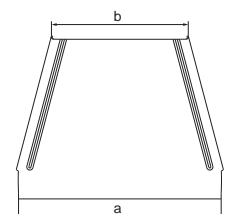

Use:

Protection of cables from dust accumulation and mechanical damage and weathering (e.g. UV radiation).

Additional information:

- recommended to use additional clips

Accessories for electrical installation

Wire Mesh Cable Tray KDS/KDSO...H60F mat.: F option: L

symbol	catalogue number	dimension L/a [mm]	quantity per package [m]	weight 1 m [kg]
KDS/KDSO60H60/3F	970506	3000/60	24	0.51
KDS/KDSO100H60/3F	970510	3000/100	24	0.73
KDS/KDSO500H60/3F	970550	3000/500	6	3.09

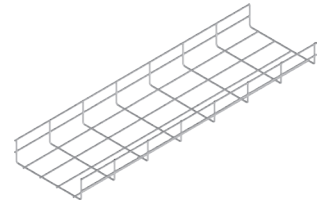
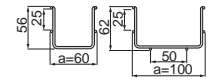

Use:

Routing a cable route.

Additional information:

- all wires in mesh trays are chamfered which prevents damage to cables
- the galvanising process is the very last, after welding and bending, which guarantees the highest quality anti-corrosion coating

Screw clamp USSNMC mat.: MC

symbol	catalogue number	weight 1 pc. [kg]	quantity per package [pcs.]
USSNMC	9002015	0.04	100

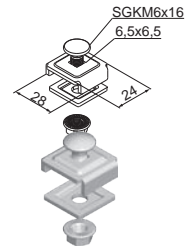

Use:

Connecting mesh trays and trays with fittings.

Additional information:

- when connecting trays with:
- heights H60 and width: 60 we use 2x USSN/USSOMC, 100 - 3x USSN/USSOMC, 200-400 - we use 4x USSN/USSOMC, 500-600 - 5x USSN/USSOMC
- additional mounting bottom of the shaped piece with a mesh tray

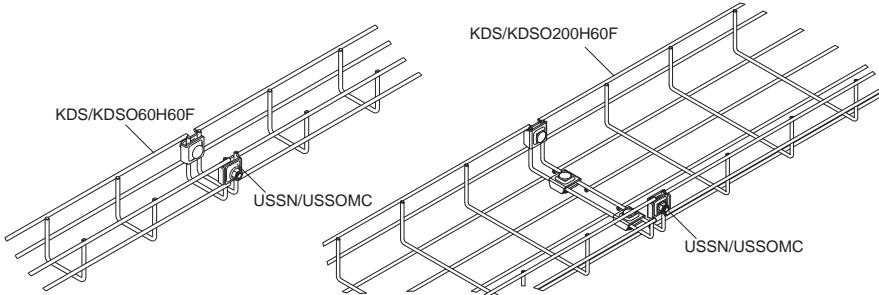

1 - Electrical installation in a KDS/KDSO60H60/3MC Wire Mesh Cable Tray

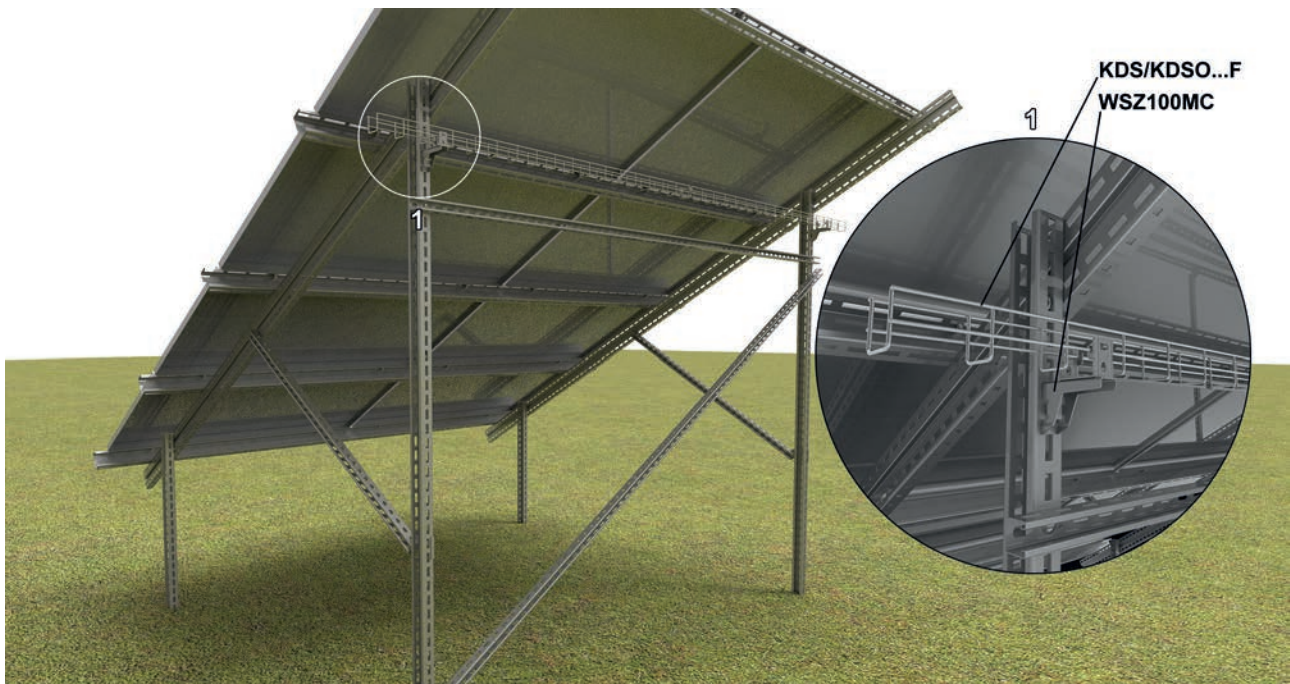

Accessories for electrical installation

Bracket		WWS...MC	mat.: MC			
symbol	catalogue number	dimension L [mm]	load max. F_{max} [kN]	weight 1 pc. [kg]	quantity per package [pcs.]	
Material thickness = 1.5 mm						
WWS100MC	7105105	110	0.90	0.19	50	
WWS150MC	7105155	160	1.00	0.21	50	

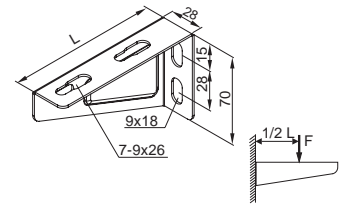

Use:
Mounting cable trays.

Additional information:
– high strength parameters

Bracket		WWSR100MC	mat.: MC			
symbol	catalogue number	dimension L/H [mm]	load max. F_{max} [kN]	weight 1 pc. [kg]	quantity per package [pcs.]	
Material thickness = 1.5 mm						
WWSR100MC	7518105	115/54	1.60	0.20	100	

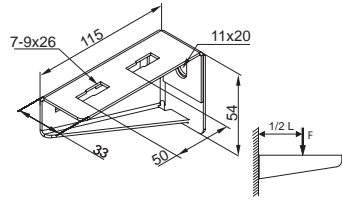

Use:
Mounting mesh trays, regular trays, cable ladders, pipes and other elements.

Additional information:
– high strength parameters
– single bolt mounting

Bracket		WSZN...MC	mat.: MC			
symbol	catalogue number	dimension L [mm]	load max. F_{max} [kN]	weight 1 pc. [kg]	quantity per package [pcs.]	
Material thickness = 2.0 mm						
WSZN100MC	9733105	110	1.30	0.14	100	
WSZN150MC	9733155	160	1.20	0.21	100	

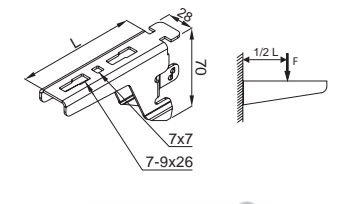

Use:
Installation of cable trays to rear support posts of PV structures.

Additional information:
– high strength parameters
– quick and easy mounting
– suitable for CT70H50/...NMC, CWT70H50/...NMC and CWE100H50/...NMC profiles

1 - Quick assembly of the WSZN...MC Bracket to the CWT70H50...NMC support legs

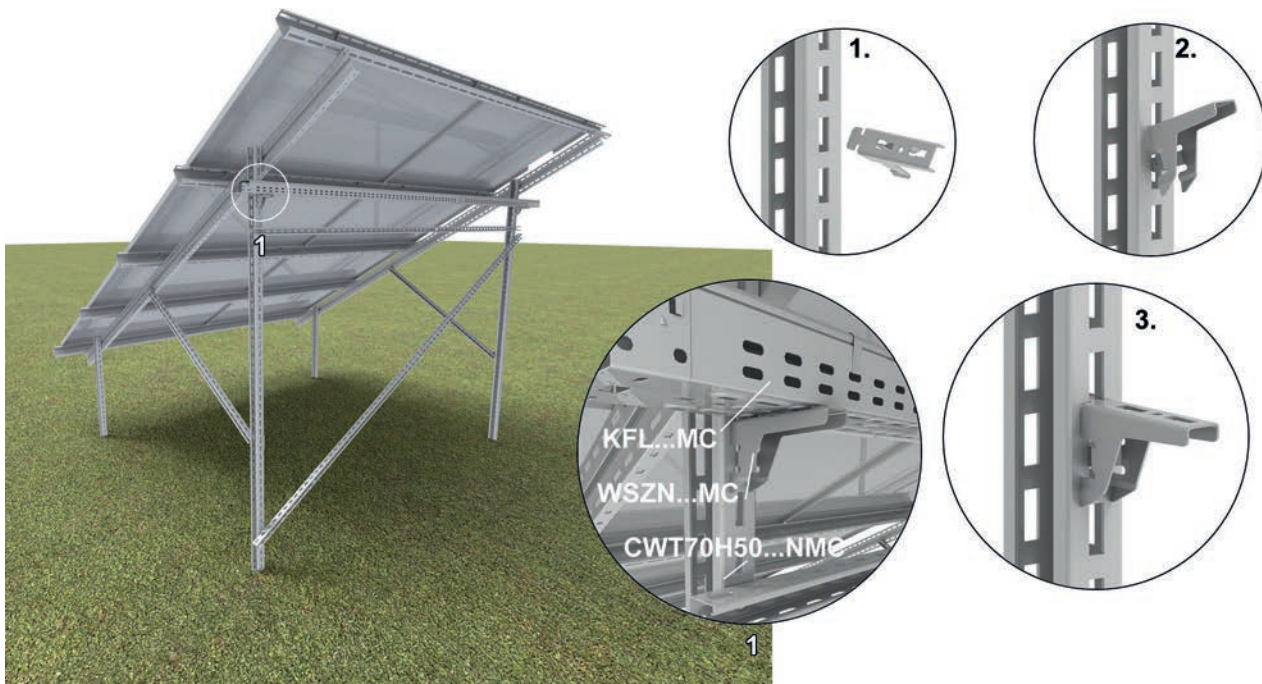

Accessories for electrical installation

Mounting clip

OMPVMC

mat.: MC

symbol

catalogue number

weight
1 pc. [kg]

quantity
per
package [pcs.]

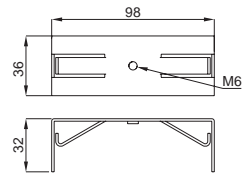
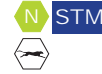

Material thickness = 1.5 mm

OMPVMC	856025	0.06	100
--------	--------	------	-----

Use:

Mounting mesh trays.

Additional information:

- quick and stable mounting

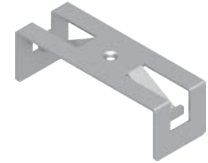

Mounting Plate

BMPV

mat.: MC

symbol

catalogue number

weight
1 pc. [kg]

quantity
per
package [pcs.]

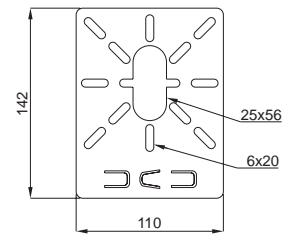

Material thickness = 1.0 mm

BMPV	800205	0.13	100
------	--------	------	-----

Use:

Installation of electrical equipment

Additional information:

- quick and easy mounting without tools
- universal mounting of various accessories, e.g. junction boxes, power optimizers
- montaż pod panelem fotowoltaicznym chroni osprzęt przed warunkami atmosferycznymi



Example of installing the PMCPV mounting base, OMPV mounting clamp, and BMPV mounting plate

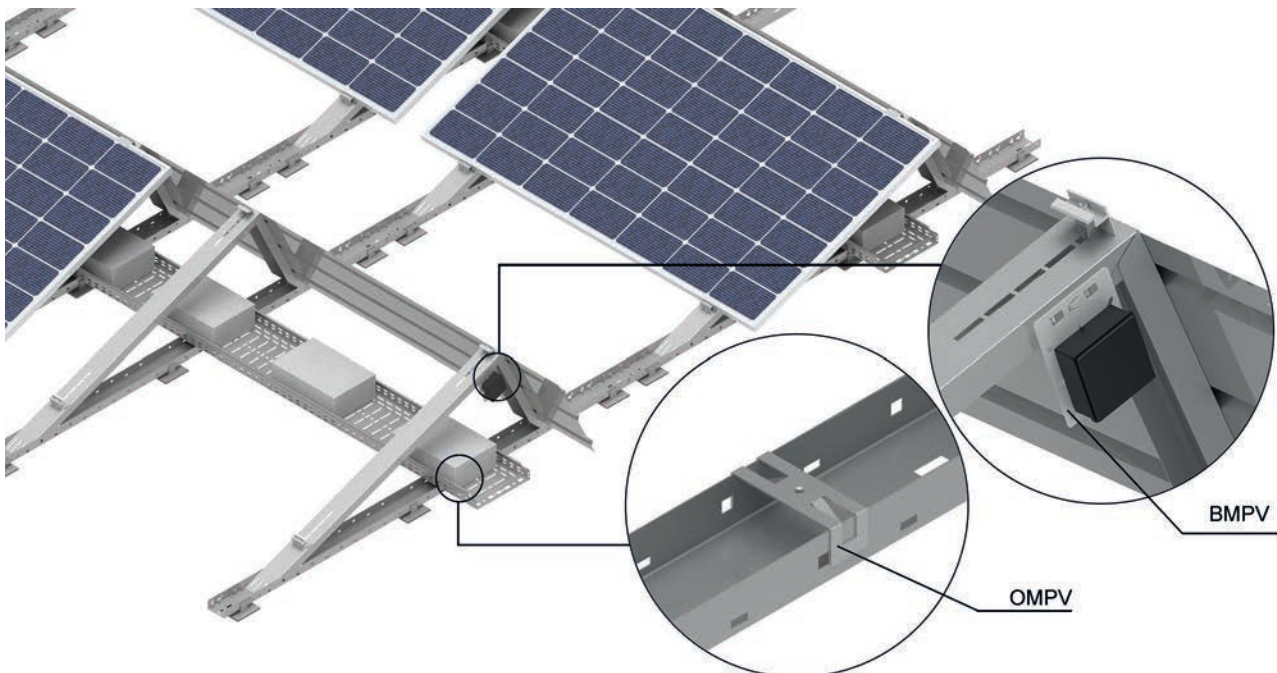

Accessories for electrical installation

Mounting base for wire cable tray

PMKS

mat.: MC

symbol	catalogue number	weight 1 pc. [kg]	quantity per package [pcs.]
--------	------------------	-------------------	-----------------------------

N STM

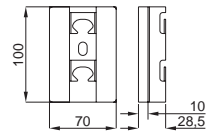

Material thickness = 1.5 mm

PMKS	856010	0.19	50
------	--------	------	----

Use:

Installation of cable routes on flat roofs without interfering with the roof covering. Bases prevent damage during installation and operation.

Additional information:

- quick and screwless mounting
- the stand is equipped with vibration insulating rubber



Base Plate

PMU1

mat.: MC

symbol	catalogue number	weight 1 pc. [kg]	quantity per package [pcs.]
--------	------------------	-------------------	-----------------------------

N STM

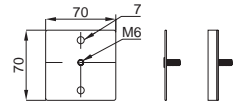

Material thickness = 2.0 mm

PMU1	856015	0.14	50
------	--------	------	----

Use:

Installation of cable routes on flat roofs without interfering with the roof covering. Bases prevent damage during installation and operation.

Additional information:

- quick and screwless mounting
- the stand is equipped with vibration insulating rubber

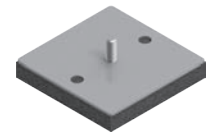
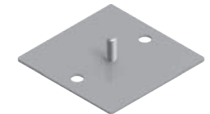

Base Plate

PMU2

mat.: MC

symbol	catalogue number	weight 1 pc. [kg]	quantity per package [pcs.]
--------	------------------	-------------------	-----------------------------

N STM

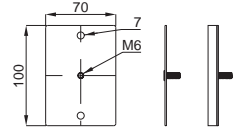

Material thickness = 2.0 mm

PMU2	856016	0.20	50
------	--------	------	----

Use:

Installation of cable routes on flat roofs without interfering with the roof covering. Bases prevent damage during installation and operation.

Additional information:

- quick and screwless mounting
- the stand is equipped with vibration insulating rubber

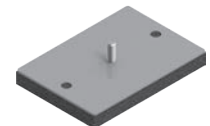

- A - Installation of the PMKS base
- B - Installation of the PMU1 universal base
- C - Installation of the PMU2 universal base

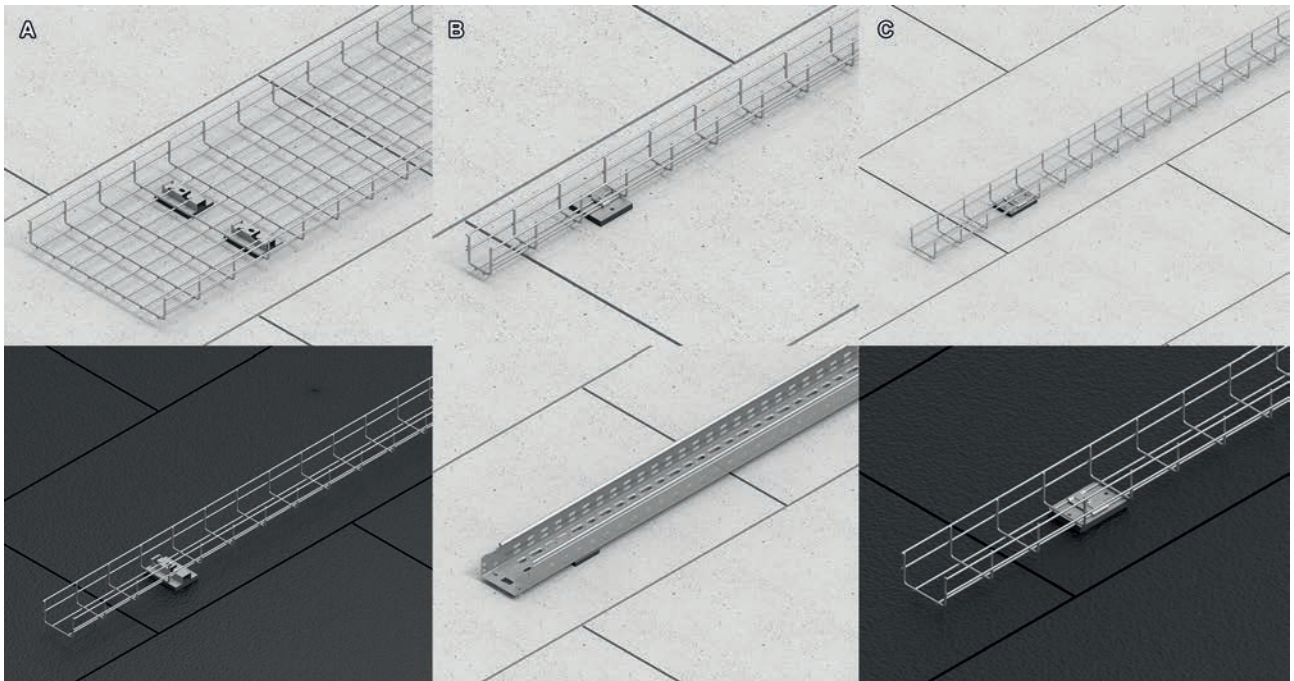

Accessories for electrical installation

Solar cable holder	UKS1	mat.: PA	quantity per package [pcs.]
symbol	catalogue number	thickness a	
UKS1	991021	0,8-3 mm	100

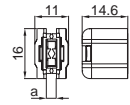

Additional information:

- quick and stable mounting
- visually pleasant installation
- effective corrosion protection
- thickness of the structural element for mounting brackets - from 0.8 to 3.0 mm
- a plastic cable tie with a maximum width of 4.8 mm should be used



Solar cable holder	UKS2	mat.: PA	quantity per package [pcs.]
symbol	catalogue number	thickness a	
UKS2	991022	0,8-3 mm	100

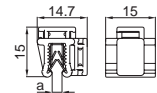

Use:

Routing solar cables along panel frames underneath the panels.

Additional information:

- quick and stable mounting
- visually pleasant installation
- effective corrosion protection
- thickness of the structural element for mounting brackets - from 0.8 to 3.0 mm
- a plastic cable tie with a maximum width of 4.8 mm should be used



Solar cable holder	UKS3	mat.: PA	quantity per package [pcs.]
symbol	catalogue number	thickness a	
UKS3	991023	0,8-3 mm	100

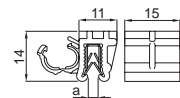

Use:

Routing solar cables along panel frames underneath the panels.

Additional information:

- quick and stable mounting
- visually pleasant installation
- effective corrosion protection
- thickness of the structural element for mounting brackets - from 0.8 to 3.0 mm
- bracket designed for cables with an outer diameter of 5–7 mm

1 - Example of installing solar cables using USK1 holders

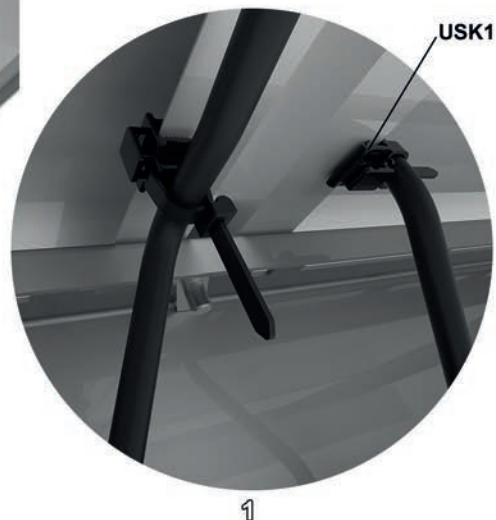
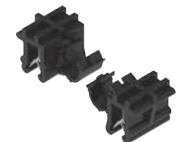

Accessories for electrical installation

Clamp	ZSK1/6/2	mat.: SCS	quantity per package [pcs.]
symbol	catalogue number	dimension Ø/g [mm]	
Material thickness = 1.0 mm			
ZSK1/6/2	792901	7-8/2-4	100

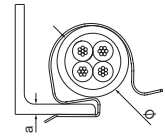

Use:
Routing solar cables along panel frames underneath the panels.

Additional information:
– screwless mounting



Inverter Cover	DI	mat.: MC	quantity per package [pcs.]
symbol	catalogue number	weight 1 pc. [kg]	
Material thickness = 3.0 mm			
DI	895002	6.97	1

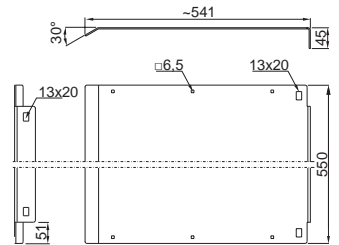

Use:
Protecting inverter against rain, snow, mechanical damages, etc.

Additional information:
– easy and quick mounting
– high strength parameters
– protecting inverter against rain, snow and mechanical damages
– possibility to extend the cover with other modules to create any width adapted to the inverter
– for the assembly use min. 2 x SGKFM10x20PV Screw Sets

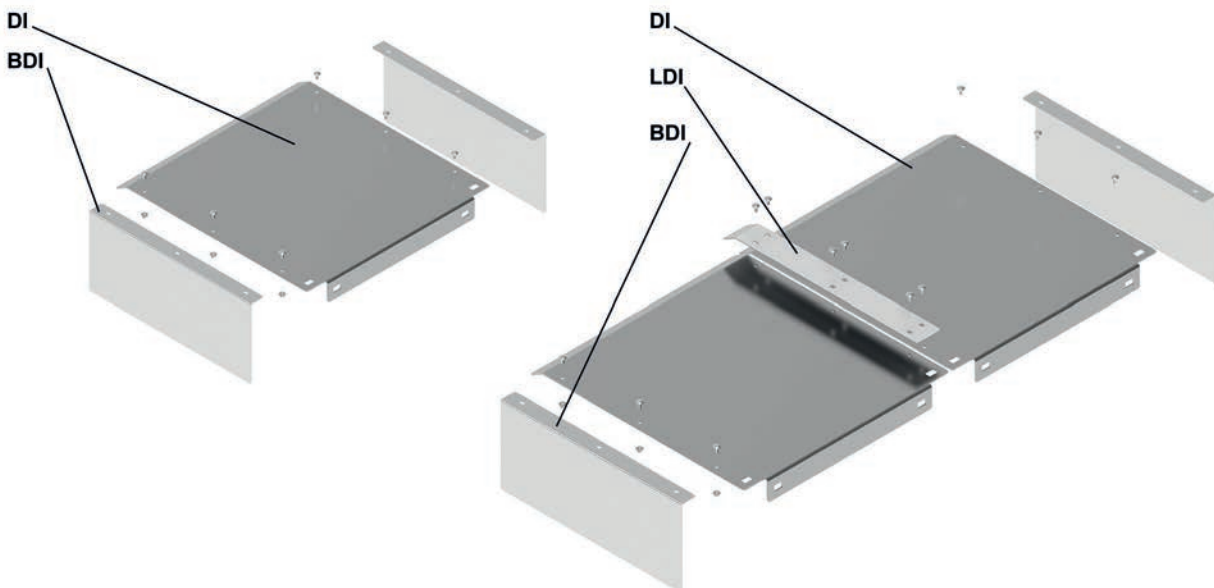
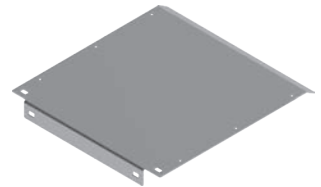

Accessories for electrical installation

Inverter Cover Side

BDI

mat.: MC

symbol	catalogue number	weight 1 pc. [kg]	quantity per package [pcs.]
--------	------------------	----------------------	-----------------------------------

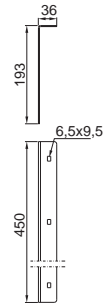

Material thickness = 2.0 mm

BDI	895003	1.60	1
-----	--------	------	---

Use:

Stiffening the cover, inverter side cover.

Additional information:

- easy and quick mounting
- high strength parameters
- protecting inverter against rain, snow and mechanical damages
- possibility to extend the cover with other modules to create any width adapted to the inverter
- symmetrical shape allowing installation on the left and right side of the cover
- for the assembly use min. 3 x SGKFM6x12 Screw Sets



Inverter Cover Connector

LDI

mat.: MC

symbol	catalogue number	weight 1 pc. [kg]	quantity per package [pcs.]
--------	------------------	----------------------	-----------------------------------

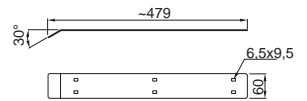

Material thickness = 2.0 mm

LDI	895004	0.45	1
-----	--------	------	---

Use:

Connecting inverter covers.

Additional information:

- easy and quick mounting
- high strength parameters
- protecting inverter against rain, snow and mechanical damages
- possibility to extend the cover with other modules to create any width adapted to the inverter
- stable connection of two covers for tightness
- for the assembly use min. 6 x SGKFM6x12 Screw Sets

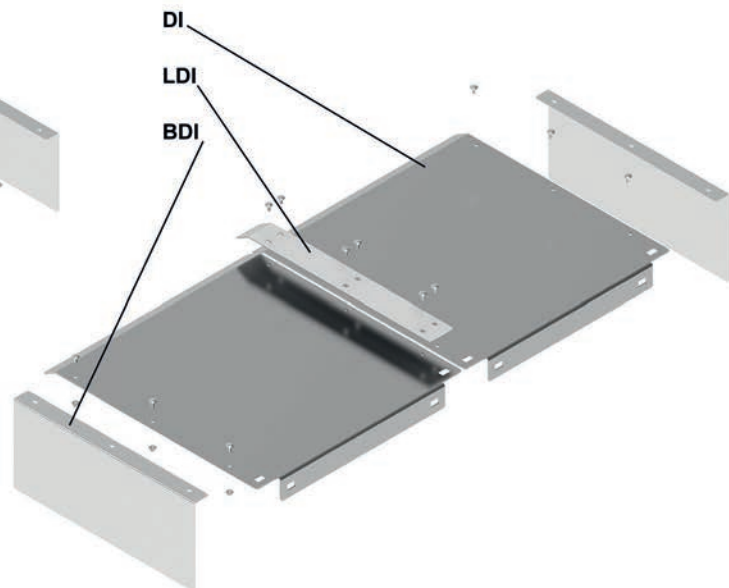
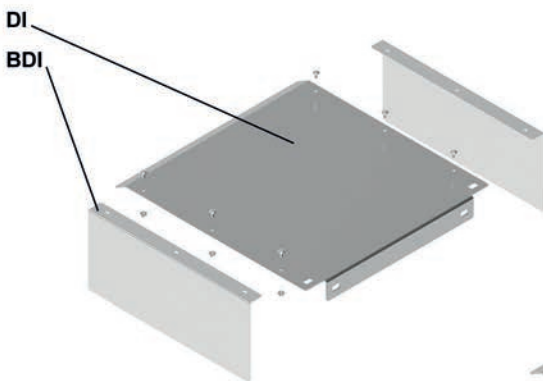

Assembly of a complete covering for inverter fixed to an existing freestanding structure for photovoltaic panels



Assembly of a complete covering for inverter fixed to an independent freestanding structure



Accessories for electrical installation

Zinc paste

WSZINK...

symbol	catalogue number	contents [ml]	quantity per package [pcs.]
WSZINK1000	650001	1000	1
WSZINKS400	650003	400	1
WSZINK250	650002	250	1



Use:

Effective corrosion protection.

Additional information:

- WSZINKS400 – spray paste
- effective corrosion protection
- various capacities to suit customer needs
- aerosol version makes it easy to spread the paste quickly
- very high zinc content ~75% (more than 90% in pigment)

Sponge rubber

EPDMW2X40

symbol	catalogue number	quantity per package
EPDMW2x40	890000	10

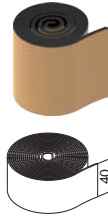

Use:

Gluing the SMA.../6 and SM... rails.

Injection mortar

ZIO...

symbol	catalogue number	weight 1 pc. [kg]	quantity per package	contents [ml]
ZIO300	653902	0.50	1	300
ZIO410	653910	0.70	1	400



Use:

Mounting steel structures, rails, racks, brackets, gates, facades, window elements, to: solid brick, perforated brick, solid blocks, lime-sand blocks, light concrete and cellular concrete, lime-sand and ceramic blocks, and in cracked and uncracked concrete.

Additional information:

- injection mortar is a vinyl ester based hybrid mortar with approval for standard mountings in cracked concrete and masonry
- thermal resistance of the mortar in the range of -40 C to +120 C allows a stable level of loads even when exposed to extreme temperatures, providing high flexibility

Support for Rooftop Installations STG... with sleeve

mat.: WG

symbol	catalogue number	dimension M	load max. F_{max} [kN]	weight 1 pc. [kg]	quantity per package [pcs.]
STG1M6	899106	M6x12	1.00	0.60	1
STG1M8	899107	M8x12	1.00	0.60	1
STG3	899108	M8x12	6.00	1.06	1

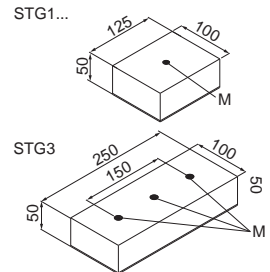

Use:

Support system for setting up cable routes, air-conditioning equipment, etc. on roofs. It is also used in the construction of roof walkways.

Additional information:

- mounting of load-bearing structures on roofs covered with roofing felt, without interfering with the protective coating of the roof
- foot made of anti-slip material resistant to UV and chemicals
- support factory-glued with an insulating layer

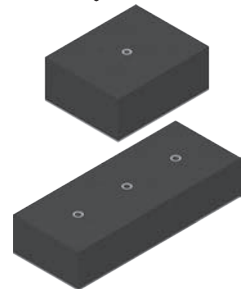

Rooftop Support with aluminum STGA... rail

mat.: WGA

symbol	catalogue number	internal dim. L [mm]	load max. F_{max} [kN]	weight 1 pc. [kg]	quantity per package [pcs.]
STGA250	899100	250	6.00	1.06	1
STGA400	899101	400	6.00	2.20	1
STGA600	899102	600	6.00	3.40	1

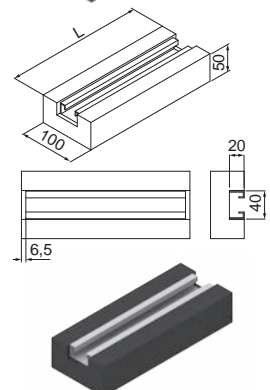

Use:

Support system for setting up cable routes, air-conditioning equipment, etc. on roofs. It is also used in the construction of roof walkways.

Additional information:

- mounting of load-bearing structures on roofs covered with roofing felt, without interfering with the protective coating of the roof
- foot made of anti-slip material resistant to UV and chemicals
- support factory-glued with an insulating layer
- mounting bases to the roof feet using SRM8x25F, SRM10x20F or SRM10x25F channel nut bolt

WGA - vulcanised rubber black, aluminum rail,
WGMC - vulcanised rubber black, steel rail in Mangelis® coating

Accessories for electrical installation

Rooftop Support with steel rail STGS...

mat.:
WGMC

symbol	catalogue number	internal dim. L [mm]	load max. F_{max} [kN]	weight 1 pc. [kg]	quantity per package [pcs.]
STGS250MC	899103	250	6.00	1.06	1
STGS400MC	899104	400	6.00	2.20	1
STGS600MC	899105	400	6.00	3.40	1

N STM

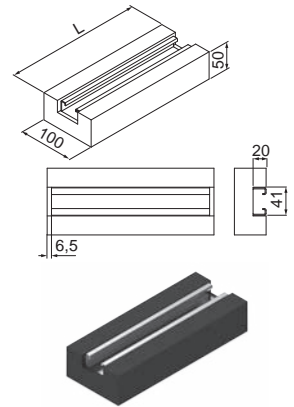

Use:

Support system for setting up cable routes, air-conditioning equipment, etc. on roofs. It is also used in the construction of roof walkways.

Additional information:

- mounting of load-bearing structures on roofs covered with roofing felt, without interfering with the protective coating of the roof
- foot made of anti-slip material resistant to UV and chemicals
- support factory-glued with an insulating layer
- mounting bases to the roof feet using SRM8x25F, SRM10x20F or SRM10x25F channel nut bolt

Rooftop Support STPV180M8

STPV180M8

mat.:
WGMC

symbol	catalogue number	weight 1 pc. [kg]	quantity per package [pcs.]
STPV180M8	866689	5.00	1

N STM

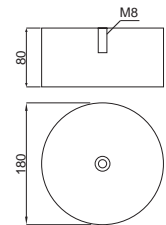

Use:

Support system for placing cable routes on roofs.

Additional information:

- mounting of load-bearing structures on roofs covered with roofing felt, without interfering with the protective coating of the roof
- foot made of anti-slip material resistant to UV and chemicals



1 - Electrical installation routed in a cable tray

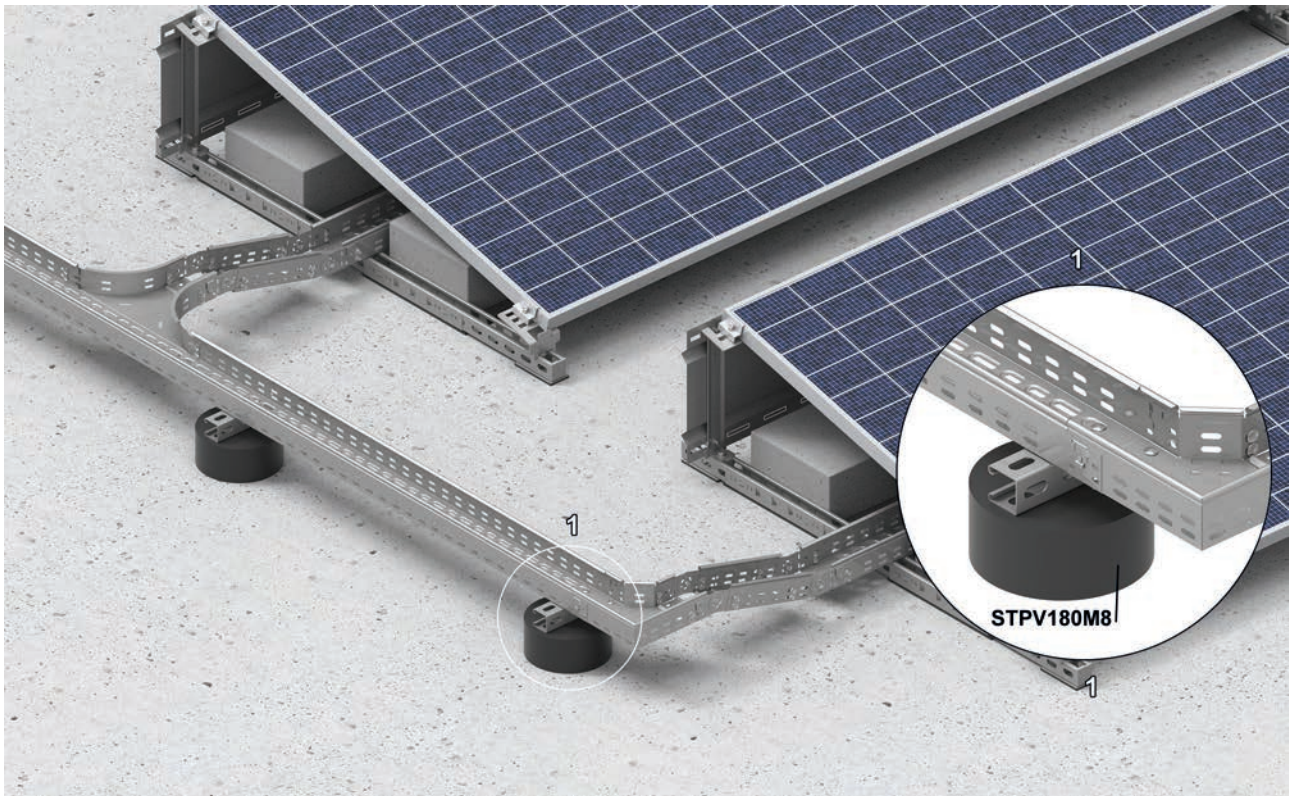

Electric vehicle charging station SLWP1500 mat.: E option: L

symbol	catalogue number	weight 1 pc. [kg]	quantity per package [pcs.]
SLWP1500	881511	46.00	1



Use:

Station for safe and reliable charging of electric vehicles.

Additional information:

- aesthetic routing of the power cable inside the pole
- high strength parameters
- inspection door allowing easy access for the installer
- pole canopy limits the impact of weather conditions on the charging station
- poles are supplied for self-assembly, without a charging cable – optional – each package includes a simple manual
- WallBox charger BA-11kW or 22kW
- phases: 3
- IP65
- connector: Type 2 socket or integrated Type 2 cable with a length of 6 or 10 meters
- connection: Bluetooth and WiFi
- mobile application: Green Wallbox (iOS / Android)

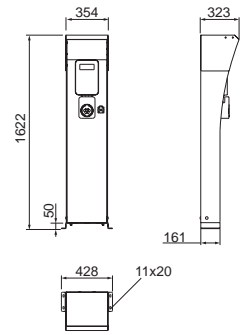

Application of the SLWP1500 pole



E - stainless steel, L - painting in standard RAL colour

Electric car charging station – double unit



Electric vehicle charging station SLWD1500 mat.: E option: L

symbol	catalogue number	weight 1 pc. [kg]	quantity per package [pcs.]
SLWD1500	881521	46.00	1

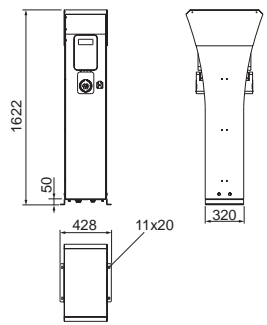

Use:

Station for safe and reliable charging of electric vehicles.

Additional information:

- two-sided mounting of the charging station
- aesthetic routing of the power cable inside the pole
- high strength parameters
- inspection door allowing easy access for the installer
- pole canopy limits the impact of weather conditions on the charging station
- poles are supplied for self-assembly, without a charging cable – optional – each package includes a simple manual
- WallBox charger BA-11kW or 22kW
- phases: 3
- IP65
- connector: Type 2 socket or integrated Type 2 cable with a length of 6 or 10 meters
- connection: Bluetooth and WiFi
- mobile application: Green Wallbox (iOS / Android)

Application of the SLWD1500 pole



E - stainless steel, L - painting in standard RAL colour



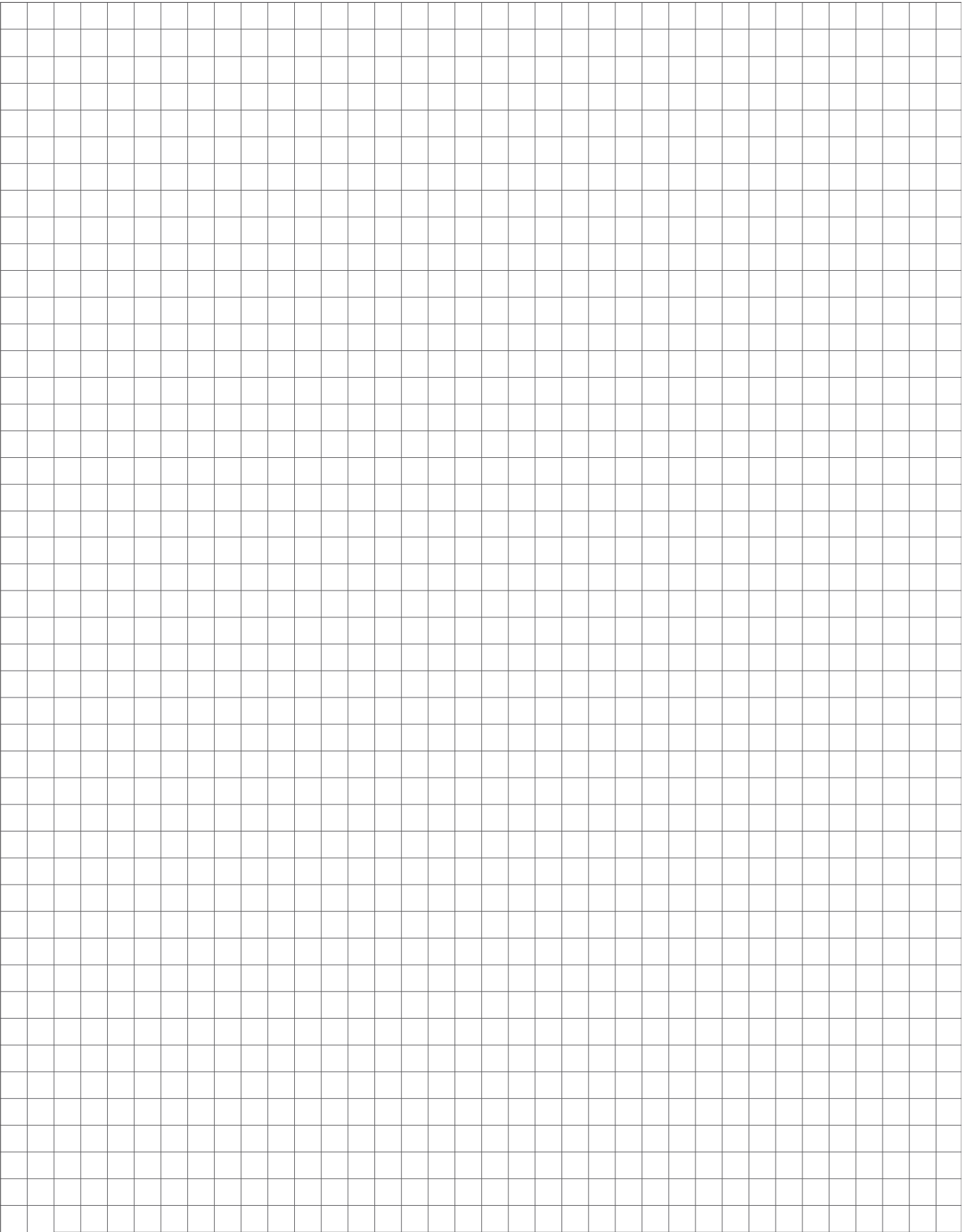



Alphabetical index by name

PRODUCT.....	PAGE
Adapter APPMC	136
Add-on Tee CLICK with Magnelis coating TKDFJ...H60MC	150
Add-on Tee with Magnelis coating TKD...H60MC	150
Adjustable Bend 90° with Magnelis coating KKRJP...H60MC	149
Aluminium angle profile KT...A	108
Aluminium mounting rail SM...A	85
Aluminium mounting rail SMA	85
Aluminium Profile Connector LPAN30	83
Aluminium Profile Connector LPAN40	80
Aluminium profile PAL30H32	83
Aluminium profile PAL40H120/6,6	82
Aluminium profile PAL40H40	80
Aluminium profile PAL40H80/6,6	82
Anchor Bolt PSR...F	145
Articulated rod hanger WPPGTE	138
Ballast base PBK...MC	125
Base Plate PCB100	111
Base Plate PCB70	111
Base Plate PCS100	109
Base Plate PCS70	109
Base Plate PMU1	164
Base Plate PMU2	164
Bottom profile PDTSMC	120
Bottom profile PDTSWZMC	120
Bracket WSZN...MC	162
Bracket WWS...MC	162
Bracket WWSR100MC	162
Cable Tray Angle Connector with Magnelis coating LKJ...H60MC	147
Cable Tray Articulated Connector with Magnelis coating LG...H60MC	147
Cable Tray CLICK with Magnelis coating KFL...H60/3MC	146
Cable Tray with Magnelis coating KBL...H60/3MC	146
Channel base with vibro-insulating rubber PC	121
Channel CBT70H50...MC	104
Channel CCS50H35/...MC	107
Channel connector BUU1MC	138
Channel connector LC...70NMC	112
Channel connector LCCW50H35MC	107
Channel connector LCD100NMC	112
Channel connector LCK1ES	138
Channel connector LCTW100H50MC	101
Channel connector LCWR100H50MC	102
Channel CP50H35...MC	106
Channel CT70H50...NMC	103
Channel nut NRM8PV	139
Channel nut NRM8PV	139
Channel with Magnelis coating CC55H50...MC	106
Clamp ZSK1/6/2	166
CLICK ballast base with height adjustment SKR41MC	126
CLICK ballast base with height adjustment SKR95MC	126
CLICK ballast base with height adjustment SKRB41MC	127
CLICK ballast base with height adjustment SKRB95MC	127
CLICK Cross-over with Magnelis coating CZKFJ...H60MC	151
CLICK Left Reducer with Magnelis coating RKLFLJ...H60MC	151
CLICK Right Reducer with Magnelis coating RKPFLJ...H60MC	152
CLICK Tee with Magnelis coating TKFJ...H60MC	149
Connector LC40H35MC	84
Connector LCCNMC	118
Connector SPV	113
Connector with Magnelis coating LC41H41MC	105
Connector with Magnelis coating LPU...H60MC	147
Cover Clamp ZPNNH60E2	154
Cover For 45° Horizontal Bend with Magnelis coating PKKMFJ...MC	156
Cover For 45° Horizontal Bend with Magnelis coating PKKMJ...MC	157
Cover For 90° Horizontal Bend with Magnelis coating PKKFJ...MC	156
Cover For 90° Horizontal Bend with Magnelis coating PKKJ...MC	156
Cover For Add-on Tee CLICK with Magnelis coating PTKDFJ...MC	158
Cover For Add-on Tee with Magnelis coating PTKDJ...MC	158
Cover For CLICK Horizontal Cross-over with Magnelis coating PCZKFJ...MC	158
Cover for CLICK right reducer with Magnelis coating PRKPFJ100/50MC	159
Cover for CLICK straight reducer with Magnelis coating PRKSFJ100/50MC	159
Cover For Cross-over with Magnelis coating PCZKJ...MC	158
Cover For Horizontal Tee CLICK with Magnelis coating PTKFJ...MC	157
Cover For Horizontal Tee with Magnelis coating PTKJ...MC	157
Cover for Left Reducer with Magnelis coating PRKLJ100/50MC	160
Cover For Reducer CLICK left with Magnelis coating PRKLFJ100/50MC	159
Cover for Reduction Tee with Magnelis coating PTRRZP...MC	158
Cover For Right Reducer with Magnelis coating PRKPJ100/50MC	160
Cover For Straight Reducer with Magnelis coating PRKSJ100/50MC	160
Cover with Magnelis coating PKL...MC	154
Edge Protection Plate with Magnelis coating BZK...MC	153
Edge Protection Strip TOZ	155
Edge Protection Strip TOZ14	155
Electric vehicle charging station SLWD1500	172
Electric vehicle charging station SLWP1500	171
End panel bolt adapter ASPKMC	96
Ground Screw GSW76x...N	110
Grounding Washer PUAP	98
Grounding Washer PUP	98
Grounding Washer PUPK	99
Grounding Washer PUPL	99
Head Plate with Magnelis coating PSF70x50MC	110
Holder - Bottom UPDMC	122
Holder - Top UPG...MC	123
Holder for seam sheet roofing UBZRE	134
Holder for seam sheet roofing UBZRE	134
Horizontal Bend 45° CLICK with Magnelis coating KKMFLJ...H60MC	148
Horizontal Bend 90° CLICK with Magnelis coating KKFJ...H60MC	148
Horizontal Bend 90° with Magnelis coating KKBJ...H60MC	148
Horizontal Bend 90° with Magnelis coating KKBJ...H60MC	149
Horizontal Cross-over with Magnelis coating CZKBJ...H60MC	151
Horizontal Tee with Magnelis coating TKBJ...H60MC	149
Injection mortar ZIO	169
Inverter Cover Connector LDI	167
Inverter Cover DI	166
Inverter Cover Side BDI	167
Joint Protection Plate with Magnelis coating BL...MC	153

PRODUCT.....	PAGE
Large Washer PW8F	140
Left Reducer with Magnelis coating RKLBJ...H60MC	152
Middle adapter for panel mounting bracket ADBIPUFMC	97
Middle holder CLICK PUF EK	92
Middle holder CLICK PUFK	91
Middle holder for free-standing structures UPP...MC	95
Middle holder PUF	93
Middle holder PUF E	94
Middle panel bolt adapter ASPGMC	96
Middle panel bolt adapter ASPPMC	96
Middle panel clamp with grounding washer PUFEP	87
Middle panel clamp with grounding washer PUF P	87
Middle panel CLICK-clamp with grounding washer PUFEPK	89
Middle panel CLICK-clamp with grounding washer PUFPK	89
Mounting adapter AD	145
Mounting base for wire cable tray PMKS	164
Mounting clip OMPVMC	163
Mounting Plate BMPV	163
Mounting rail connector LPSMA	86
Mounting rail connector LPSMA40	86
Mounting rail connector LPSMA70	86
Nut NKZM...E	142
Nut NKZM...F	142
Nut NS...E	141
Profile BDFCH100...NMC	100
Profile BDFCH120...NMC	100
Profile BDFTH120...NMC	100
Profile Connector LBDFEMC	114
Protective cap for aluminium profile NOPAL	81
Protective cap for aluminium profile NOWPAL40x40SR	81
Protective cap NOW100x50SR	102
Reduction tee with Magnelis coating TRJ...H60MC	151
Right Reducer with Magnelis coating RKPBJ...H60MC	152
Rod Connector NLM6E	142
Rod hanger WPTMC	142
Roof fixing - adjustable DUR40E	130
Roof fixing DUF60E	131
Roof fixing DUF75E	132
Roof fixing DUFPE	133
Roof fixing DUF60E	131
Roof fixing DUF75E	132
Roof fixing DUFWE	133
Roof fixing DURSE	130
Roof fixing with steel plain tiles DUF75K	133
Roof fixing with the trap. sheet - adjustable RUBTE	135
Rooftop Support STPV180M8	170
Rooftop Support with aluminum rail STGA	169
Rooftop Support with steel rail STGS	170
Screw (set) SMM...F	141
Screw clamp USSNMC	161
Screw - double thread SWD...E	145
Screw SAM8...E	139
Screw Set SGK F	141
Screw set SKK...E	141
Screw SRM...F	141
Screw SSZM10x20E	140
Self-drilling screw with EPDM SMPD...E	143
Side adapter for panel mounting bracket ADBIBUFMC	97
Side Holder BUF	93
Side Holder BUFE	94
Side Holder BUFMC	121
Side holder CLICK BUFEK	92
Side holder CLICK BUFK	91
Side panel clamp with grounding washer BUFE P	88
Side panel clamp with grounding washer BUFP	88
Side panel CLICK-clamp with grounding washer BUFEPK	90
Side panel CLICK-clamp with grounding washer BUFPK	90
Sleeper padding SBR	125
Sleeper padding SBV	125
Slide nut with a ball NKW8M8A	143
Solar cable holder UKS1	165
Solar cable holder UKS2	165
Solar cable holder UKS3	165
Spacer BR45/1MC	124
Sponge rubber EPDMW2X40	141
Spring Washer PS...E	141
Square Nut NKWM8E	140
Steel Fixing Plate for Flat Roofs SPM1	115
Steel Fixing Plate for Flat Roofs SPM2	115
Steel Fixing Plate for Flat Roofs SPM3	118
Straight Reducer with Magnelis coating RKSBJ...H60MC	153
Straight Reducer with Magnelis coating RKSFJ...H60MC	152
Support Channel CC50H35...MC	107
Support Channel CWBT70H50...MC	104
Support Channel CWC100H50...NMC	101
Support Channel CWCR100H50...MC	102
Support Channel CWE100H50...NMC	104
Support Channel CWP40H35...MC	84
Support Channel CWT70H50...NMC	103
Support Channel with Magnelis coating CMP41H41...MC	105
Support for Rooftop Installations with sleeve STG	169
Threaded rod PGM6...E	145
Top profile PGTSMC	120
Top profile PGTSWZMC	120
T-screw SMHM10x...E	140
U-bolt CYB...E	137
U-bolt CYK...E	137
Upper base east-west PGWZMC	124
Wind Shield OWN...J...NMC	128
Wire Mesh Cable Tray KDSKDSO...H60F	161
Wood screw DDW8x60E	144
Wood screw DDW8x100	144
Wood screw DDW8x100E	144
Zinc paste WSZINK	169



Alphabetical index by symbol

PRODUCT.....	PAGE
AD.....	145
ADBIUFMC.....	97
ADBIUFMC.....	97
APPMC.....	136
ASPGMC.....	96
ASPKMC.....	96
ASPPMC.....	96
BDFCH100...NMC.....	100
BDFCH120...NMC.....	100
BDFTH120...NMC.....	100
BDI.....	167
BL...MC.....	153
BMPV.....	163
BR45/1MC.....	124
BUF.....	93
BUFE.....	94
BUFEK.....	92
BUFEP.....	88
BUFEPK.....	90
BUFK.....	91
BUFMC.....	121
BUFP.....	88
BUFPK.....	90
BUU1MC.....	138
BZK...MC.....	153
CBT70H50...MC.....	104
CC50H35...MC.....	107
CC55H50...MC.....	106
CC55H35/...MC.....	107
CMP41H41...MC.....	105
CP50H35...MC.....	106
CT70H50...NMC.....	103
CWBT70H50...MC.....	104
CWC100H50...NMC.....	101
CWCR100H50...MC.....	102
CWE100H50...NMC.....	104
CWP40H35...MC.....	84
CWT70H50...NMC.....	103
CYB...E.....	137
CYK...E.....	137
CZKBJ...H60MC.....	151
CZKFJ...H60MC.....	151
DDW6x60E.....	144
DDW8x100.....	144
DDW8x100E.....	144
DI.....	166
DUF60E.....	131
DUF75E.....	132
DUF75K.....	133
DUFPE.....	133
DUFR60E.....	131
DUFR75E.....	132
DUFWE.....	133
DUR40E.....	130
DURSE.....	130
EPDMW2X40.....	169
GSW76x...N.....	110
KBL...H60/3MC.....	146
KDS/KDSO...H60/3F.....	161
KFL...H60/3MC.....	146
KKBJ...H60MC.....	148
KKFJ...H60MC.....	148
KKMBJ...H60MC.....	149
KKMFJ...H60MC.....	148
KKRPJ...H60MC.....	149
KT...A.....	108
LBDFEMC.....	114
LC...70NMC.....	112
LC40H35MC.....	84
LC41H41MC.....	105
LCCNMC.....	118
LCCW50H35MC.....	107
LCD100NMC.....	112
LCK1ES.....	138
LCTW100H50MC.....	101
LCWR100H50MC.....	102
LDI.....	167
LG...H60MC.....	147
LKJ...H60MC.....	147
LPAN30.....	83
LPAN40.....	80
LPSMA.....	86
LPSMA40.....	86
LPSMA70.....	86
LPU...H60MC.....	147
NKWM8E.....	140
NKWSM8A.....	143
NKZM...E.....	142
NKZM...F.....	142
NLM6E.....	142
NOPAL.....	81
NOW100x50SR.....	102
NOWPAL40x40SR.....	81
NRKM8PV.....	139
NRM8PV.....	139
NS...E.....	141
OMPVMC.....	163
OWN.../...NMC.....	128
PAL30H32.....	83
PAL40H120/6,6.....	82
PAL40H40.....	80
PAL40H80/6,6.....	82
PBK...MC.....	125
PC.....	121
PCB100.....	111
PCB70.....	111

PRODUCT.....	PAGE
PCS100.....	109
PCS70.....	109
PCZKFJ...MC.....	158
PCZKJ...MC.....	158
PDTSMC.....	120
PDTSWZMC.....	120
PGM6...E.....	145
PGTSMC.....	120
PCTSWZMC.....	120
PGWZMC.....	124
PKKFJ...MC.....	156
PKKJ...MC.....	156
PKKMFJ...MC.....	156
PKKMJ...MC.....	157
PKL...MC.....	154
PMKS.....	164
PMU1.....	164
PMU2.....	164
PRKLFJ100/50MC.....	159
PRKLJ100/50MC.....	160
PRKPFJ100/50MC.....	159
PRKPJ100/50MC.....	160
PRKSFJ100/50MC.....	159
PRKSJ100/50MC.....	160
PS...E.....	141
PSF70x50MC.....	110
PSR...F.....	145
PTKDFJ...MC.....	158
PTKDJ...MC.....	158
PTKFJ...MC.....	157
PTKJ...MC.....	157
PTRRZP...MC.....	158
PUAP.....	98
PUF.....	93
PUFE.....	94
PUFEK.....	92
PUFEP.....	87
PUFEPK.....	89
PUFK.....	91
PUPF.....	87
PUPFK.....	89
PUP.....	98
PUPK.....	99
PUPL.....	99
PW8F.....	140
RKLBJ...H60MC.....	152
RKLFJ...H60MC.....	151
RKPBJ...H60MC.....	152
RKPFJ...H60MC.....	152
RKSBJ...H60MC.....	153
RKSFJ...H60MC.....	152
RUBTE.....	135
SAM8...E.....	139
SBR.....	125
SBV.....	125
SGKF...E.....	141
SKK...E.....	141
SKR41MC.....	126
SKR95MC.....	126
SKRB41MC.....	127
SKRB95MC.....	127
SLWD1500.....	172
SLWP1500.....	171
SM...A.....	85
SMA.....	85
SMDP...E.....	143
SMHM10x...E.....	140
SMM...F.....	141
SPM1.....	115
SPM2.....	115
SPM3.....	118
SPV.....	113
SRM...F.....	141
SSZM10x20E.....	140
STG.....	169
STGA.....	169
STGS.....	170
STPV180M8.....	170
SWD...E.....	145
TKBJ...H60MC.....	149
TKD...H60MC.....	150
TKDFJ...H60MC.....	150
TKFJ...H60MC.....	149
TOZ.....	155
TOZ14.....	155
TRJ...H60MC.....	151
UBZRE.....	134
UBZRPE.....	134
UKS1.....	165
UKS2.....	165
UKS3.....	165
UPDMC.....	122
UPG...MC.....	123
UPP...MC.....	95
USSNMC.....	161
WPPGTE.....	138
WPTMC.....	142
WSZINK.....	169
WSZN...MC.....	162
WWS...MC.....	162
WWSR100MC.....	162
ZIO.....	169
ZPNH60E2.....	154
ZSK1/6/2.....	166