

STRUCTURE ASSEMBLY INSTRUCTIONS W-V2K2-BI



Producer:

BAKS

ul. Jagodne 5

05-480 Karczew

Poland

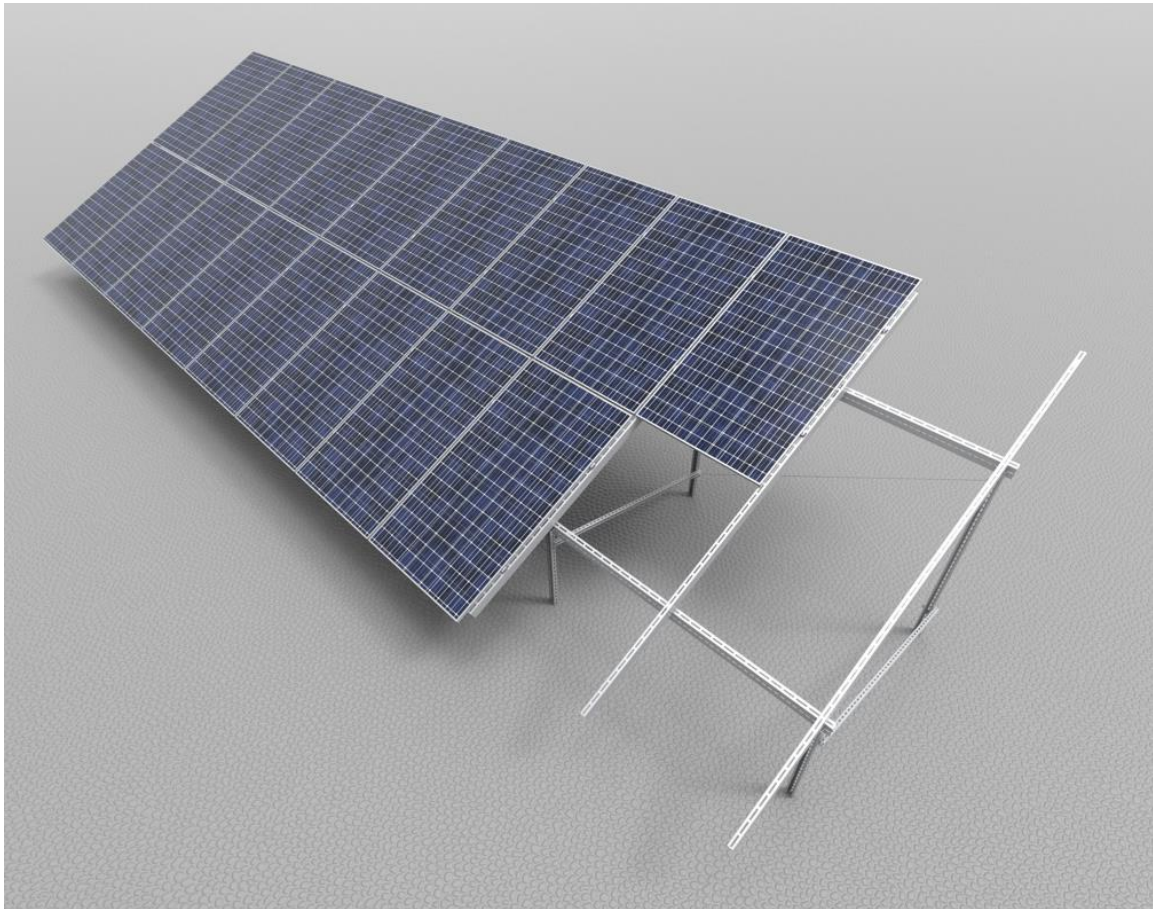

W – free-standing steel structure

V – vertical panel layout

2 – number of rows of panels

K - structure fixed to the ground by means of anchors fixed to concrete bases

2 – construction based on two support poles

BI – construction adapted to the installation of bifacial panels



1. Necessary tools for assembling structures

- Allen (ampoule) key size 6
- Cordless screwdriver with speed and torque control
- Hexagonal bit, Allen size 6 for screwdriver head
- Combination spanner size 15 mm
- Ratchet wrench with 15 mm cap,
- Extension 100-120mm for socket wrenches
- Rubber hammer
- Torque wrench range 10-45 Nm

2. General Information

- Possibility of using the structure in wind and snow zones in accordance with the following standards: PN-EN 1991-1-3 and PN-EN 1991-1-4
- Before installing the structure, read the installation instructions for photovoltaic panels
- It is recommended that the connection of BDFCH... profiles with CWC100H50 profiles, CWCR100H50 profile with CWC100H50 profiles and BUF... with CWC100H50 profiles should not be located on the last (outermost) holes
- Each CWC100H50 and CWCR100H50 profile must have at least 2 support points
- The depth of piling the profiles into the ground, the dimensions of the hole for pouring concrete and the dimensions of the foundation for anchoring the structure should be determined by the authorized constructor for the given installation
- If the mounting zone of the panel does not coincide with the perforation of the profile, it is necessary to make an adjustment on the channel connector or use an intermediate bracket of the type UPP...MC
- The panel grounding pad (PUP) is placed under the intermediate handles of the panels. A single washer has the ability to ground two adjacent panels.
- Cutting elements is allowed only with low-speed saber saws and hand saws with tools made of high-quality steel, which avoids excessive heating of the material
- Cut edges must be unconditionally protected – sanded with sandpaper, cleaned and degreased again, after drying, protect with zinc paste a minimum of three times layer.
- The concentrations connecting subsequent frames should be placed up to every 4th field of the structure
- SAM8x screws... E and NUTS NRM8PV should be tightened with a torque of 12-14 Nm
- When twisting the SGKFM10x20 screw, hold the screw head in such a position that the filling locks on the walls of the hole in which the screw is mounted, and then with the help of a screwdriver tighten the screw slowly until it is blocked in the hole. In the final phase, you need to tighten the screwdriver with a torque of 42 Nm



3. Specification of elements included in the structure W-V2B2-BI

(construction specification does not include tools)

Nr	Name	Product symbol	Purpose in construction
1	Basis	PCB70	Support pillar mounting base
2	Channel bar	CWT70H50/...NMC	Front and rear support columns
3	Channel bar	CWCR100H50/...NMC	Purlins
4	Channel bar	CWC100H50/...NMC	Rafters
5	Channel bar	CMP41H41/...MC	Bracing No. 1
6	Channel connector	LCT100H50MC	Purlin connector
7	Rod hanger	WPTMC	Bracing 2
8	Threaded rod	PGM6/...E	Bracing No. 2
9	Side handle	BUF...	Side brace fixing the panels
10	Intermediate handle	PUF	Intermediate adhesive fixing panels
11	Grounding pad	PUP	Panel grounding
12	Screw	SAM8x...E	Screw fixing the clamps
13	Spring washer	PS8E	Head washer SAM8x...E
14	Screw Set	SGKFM10x...PV	Screw + flange nut
15	Enlarged pad	PW10F	Washer
16	Rhombic nut	NRM8PV	Clamps mounting nut

Table 1 List of structural elements

Installation order:

- 1) Installation of **PCB70** bases to the concrete base and front and rear support columns **CWT70H50/...NMC** according to the information on the dimensions "L1" and "L2" taking into account their orientation with respect to the world directions shown in Figure No. 6
- 2) Installation of **CWCR100H50/... NMC** channel bars for support columns and setting the appropriate angle of the structure (detail 2)
- 3) Installation of the **CWC100H50/4.4NMC** profile connecting the front and rear supports (detail 6)
- 4) Installation of bracing No. 1 (detail 4)
- 5) Installation of bracing No. 2 (detail 5)
- 6) Installation of panel clamps (detail 7.1;76.2; 8)



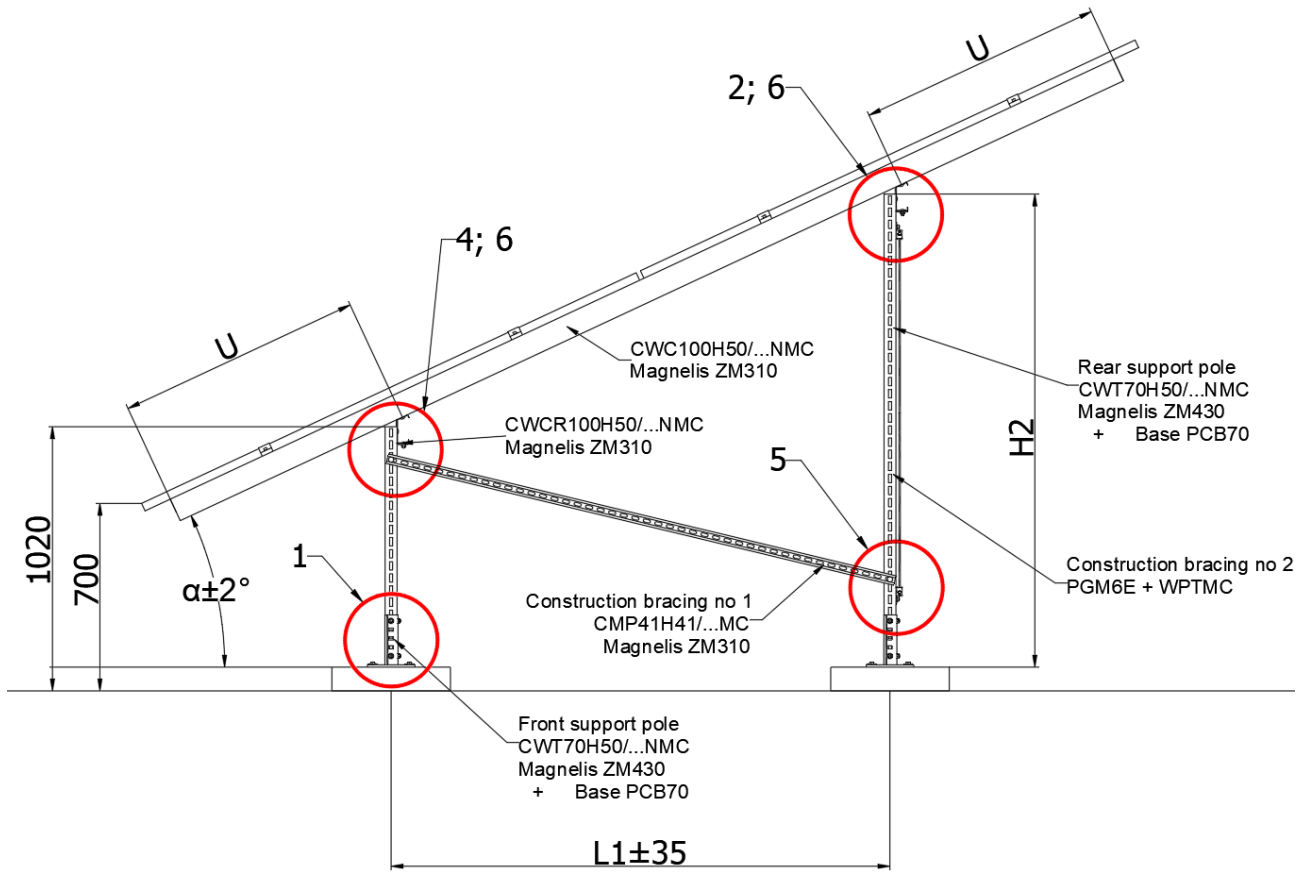

Fig. 1 Side view of the structure

The dimensions L1, L2 and H2 are closely related to the size of the panels used in the construction. They should be calculated according to the following formulas:

$$L1 = \cos(\alpha) * (\text{panel length} + 20\text{mm})$$

$$L2 = 2 * (\text{panel width} + 20\text{mm})$$

$$H2 = \tan(\alpha) * L1 + H1$$

Where " α " is the angle of inclination of the structure



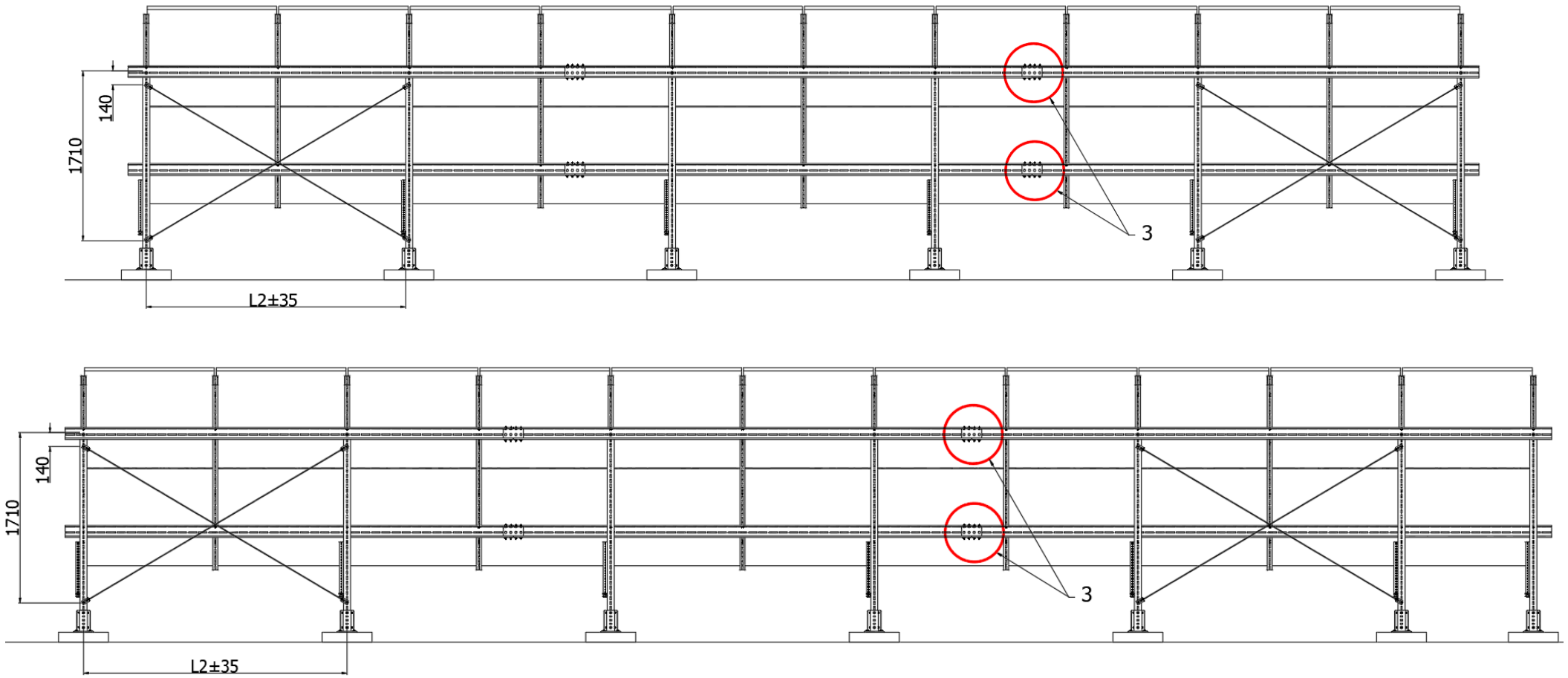

Fig. 2 View of the structure from the north with the spacing of concentrations No. 2



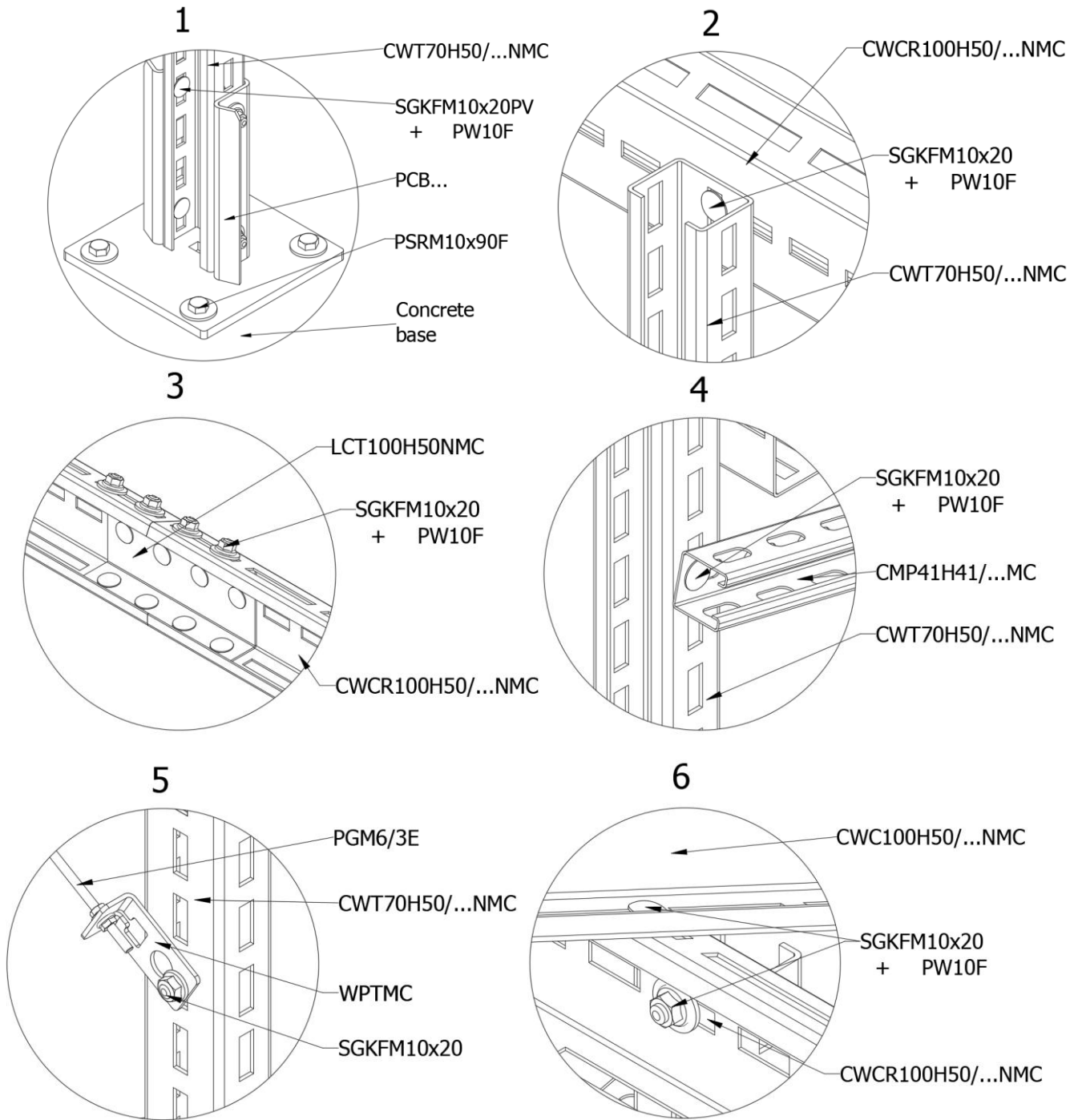

Fig. 3 Details of joining individual elements



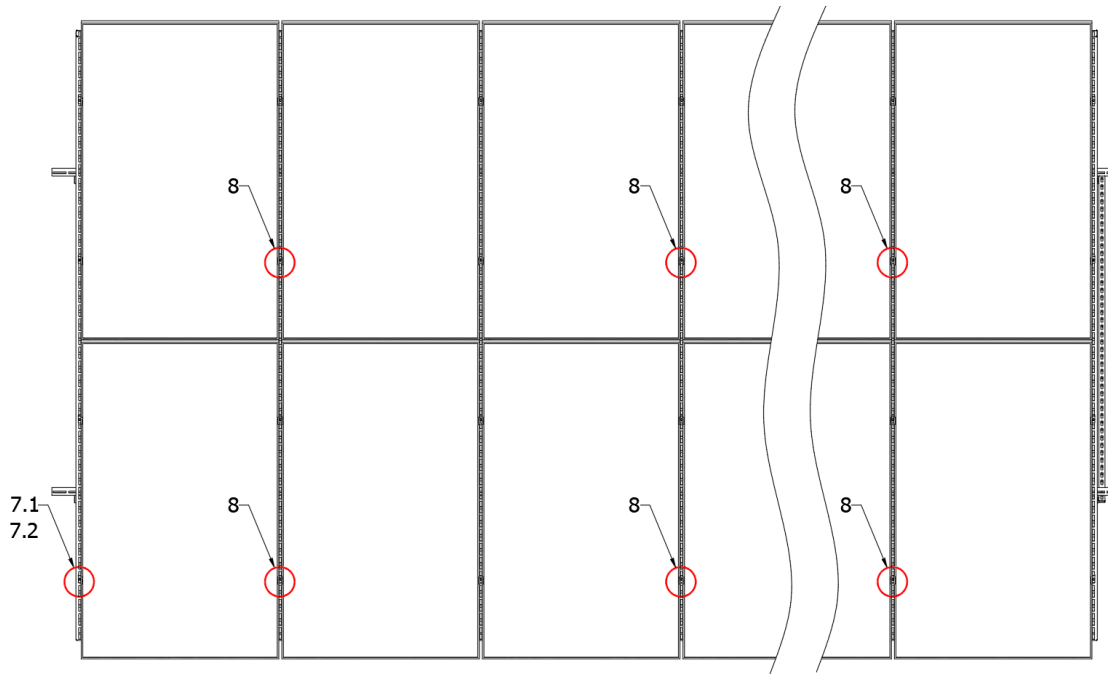
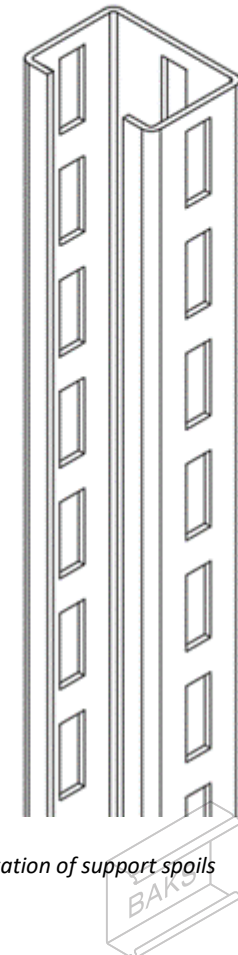
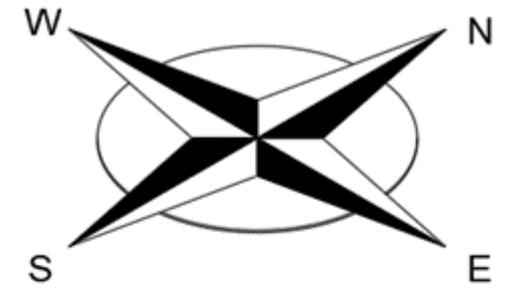

Fig. 4 View of the structure from the top



Figs. 6 Orientation of support spoils

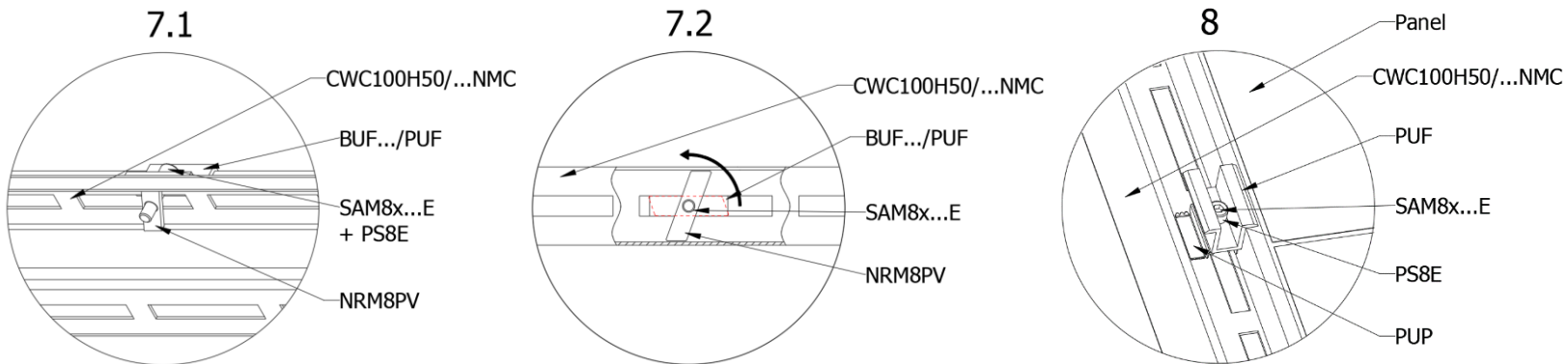

Fig. 5 Clamp mounting detail and nut locking preview